

Forgotten Books

— www.forgottenbooks.com —

Copyright © 2016 FB &c Ltd.

All rights reserved. No part of this publication may be reproduced, distributed, or transmitted in any form or by any means, including photocopying, recording, or other electronic or mechanical methods, without the prior written permission of the publisher, except in the case of brief quotations embodied in critical reviews and certain other noncommercial uses permitted by copyright law.

to the new edition of **THE MONTESSORI METHOD** by Maria Montessori:

“While Maria Montessori was putting together the basic description of her educational procedures and philosophies, Albert Einstein was at work in Switzerland, Arnold Schoenberg and Sigmund Freud in Vienna, James Joyce in Trieste, Igor Stravinsky, Pablo Picasso, Marcel Proust and Gertrude Stein in Paris, William Rutherford and Niels Bohr in Manchester, Bertrand Russell, Alfred North Whitehead, John Maynard Keynes and James George Frazer in Cambridge, Wolfgang Kohler at Tenerife, Bronislaw Malinowski in the Trobriand Islands. . . .

“Already massing behind these great figures, however, even then, were the armies of followers and expanders who would see further, in Isaac Newton’s generous phrase, because they stood on the shoulders of giants. Only in education was there to be a sudden and drastic end to the burst of innovation and analysis, synthesis and change, which was remaking almost every area of serious human interest. With the rejection of Montessori, in favor of recollections from the less perceptive Froebel and projections from the less specific Dewey, education turned away from the light of genius to darker corners that could be filled with the comfortable stuff of mediocrity.

“As recently as five years ago, anyone so rash as to mention Montessori to a group of American educators would have been told not to trouble his head about it: William Heard Kilpatrick had ‘disproved her.’ Two factors have brought Montessori’s work back to prominence in the United States: the great curriculum reform movements in math and science, which have poured out educational evidence that flows naturally into a Montessori mold; and the new concern over the education of unlucky children, both the genetically and the environmentally crippled, which inevitably looks back to the few examples of success with this intractable task and finds the handsome Dottoressa working cheerfully and productively with children in hospitals, at her *Case dei Bambini* in the primitive housing

continued on back flap

REF
372,13
M

NY PUBLIC LIBRARY THE BRANCH LIBRARIES



3 3333 01922 7590

~~CC~~
ED

**THE MONTESSORI
ELEMENTARY MATERIAL**

Maria Montessori was born in 1870, and she was the first woman ever granted a medical degree by an Italian university. As a child, she showed great ability in mathematics and originally intended to become an engineer. She did post-graduate work in psychiatry.

At the age of 28, Montessori became directress of a tax-supported school for defective children. Working thirteen hours a day *with the children*, she developed materials and methods which allowed them to perform reasonably well on school problems previously considered far beyond their capacity. Her great triumph, in reality and in the newspapers, came when she presented children from mental institutions at the public examinations for primary certificates, which was as far as the average Italian ever went in

formal education — and her children passed the exam.

Typically, she drew from her experience the vigorous conclusion — that if *these* children could be brought to the academic levels reached by normal children, then there had to be something horribly wrong with the education of normal children. And so she moved on to the *normal* children of the slums. Thereafter, by her own desire and by public demand, she was an educator, not a medical doctor.

Montessori's insights and methods are contained in three basic texts, now republished: **THE MONTESSORI METHOD, SPONTANEOUS ACTIVITY IN EDUCATION** (*The Advanced Montessori Method*, volume 1), and **THE MONTESSORI ELEMENTARY MATERIAL** (*The Advanced Montessori Method*, volume 2).

THE MONTESSORI METHOD, by Maria Montessori. Introduction by Martin Mayer. Illustrated. The education of children from 3 to 6. 448 pages.

SPONTANEOUS ACTIVITY IN EDUCATION, by Maria Montessori. *The Advanced Montessori Method*, volume 1. The education of children from 7 to 11. 384 pages.

THE MONTESSORI ELEMENTARY MATERIAL, by Maria Montessori. *The Advanced Montessori Method*, volume 2. The education of children from 7 to 11. 512 pages.

NEW EDITIONS PUBLISHED BY
ROBERT BENTLEY, INC.

18 Pleasant St., Cambridge, Massachusetts 02139



The first Montessori Elementary Class in America, opened in Rivington Street, New York, May, 1916.

*THE
ADVANCED MONTESSORI METHOD*

★ ★

**THE MONTESSORI
ELEMENTARY MATERIAL**

BY

MARIA MONTESSORI

AUTHOR OF "THE MONTESSORI METHOD," "PEDAGOGICAL
ANTHROPOLOGY," ETC.

TRANSLATED FROM THE ITALIAN BY

ARTHUR LIVINGSTON

ASSOCIATE PROFESSOR OF ITALIAN AT COLUMBIA UNIVERSITY

*WITH FORTY-FOUR ILLUSTRATIONS FROM PHOTOGRAPHS
AND WITH NUMEROUS DIAGRAMS*

1965

ROBERT BENTLEY, INC.

18 PLEASANT ST., CAMBRIDGE, MASSACHUSETTS 02139

Copyright, 1917, by
FREDERICK A. STOKES COMPANY

*All rights reserved, including that of translation into
foreign languages.*

Printed in the U.S.A.

TRANSLATOR'S NOTE

So far as Dr. Montessori's experiments contain the affirmation of a new doctrine and the illustration of a new method in regard to the teaching of Grammar, Reading and Metrics, the following pages are, we hope, a faithful rendition of her work. But it is only in these respects that the chapters devoted to these subjects are to be considered a translation. It will be observed that Dr. Montessori's text is not only a theoretical treatise but also an actual text-book for the teaching of Italian grammar, Italian reading and Italian metrics to young pupils. Her exercises constitute a rigidly "tested" material: her Italian word lists are lists which, in actual practise, have accomplished their purpose; her grammatical categories with their relative illustration are those actually mastered by her Italian students; her reading selections and her metrical analyses are those which, from an offering doubtless far more extensive, actually survived the experiment of use in class.

It is obvious that no such value can be claimed for any "translation" of the original material. The categories of Italian grammar are not exactly the categories of English grammar. The morphology and, to a certain extent, the syntax of the various parts of speech differ in the two languages. The immediate result is that the Montessori material offers much that is inapplicable and fails to touch on much that is essential to the teaching of English grammar. The nature and extent of the difficulties thus arising are more fully set forth in connection with specific cases in

our text. Suffice it here to indicate that the English material offered below is but approximately "experimental," approximately scientific. The constitution of a definitive Montessori material for English grammar and the definitive manner and order of its presentment must await the results of experiments in actual use. For the clearer orientation of such eventual experiments we offer, even for those parts of Italian grammar which bear no relation to English, a virtually complete translation of the original text; venturing meanwhile the suggestion that such studies as Dr. Montessori's treatise on the teaching of Italian noun and adjective inflections — entirely foreign to English — may prove valuable to all teachers of modern languages. While it might seem desirable to isolate such superfluous material from the "English grammar" given below, we decided to retain the relative paragraphs in their actual position in the Italian work, in order to preserve the literal integrity of the original method. Among our additions to the text we may cite the exercises on the possessive pronouns — identified by Dr. Montessori with the possessive adjectives — the interrogatives and the comparison of adjectives and adverbs.

Even where, as regards morphology, a reasonably close adaptation of the Italian material to English uses has been possible, it by no means follows that the pedagogical problems involved remain the same. The teaching of the relative pronoun, for instance, is far more complicated in English than in Italian; in the sense that the steps to be taken by the child are for English more numerous and of a higher order. Likewise for the verb, if Italian is more difficult as regards variety of forms, it is much more simple as regards negation, interrogation and progressive action. We have made no attempt to be consistent in adapting the

translation to such difficulties. In general we have treated the parts of speech in the order in which they appear in the Italian text, though actual experiment may prove that some other order is desirable for the teaching of English grammar. The English material given below is thus in part a translation of the original exercises in Italian, in part new. In cases where it proved impossible to utilize any of the Italian material, an attempt has been made to find sentences illustrating the same pedagogical principle and involving the same number and character of mental processes as are required by the original text.

The special emphasis laid by Dr. Montessori upon selections from Manzoni is due simply to the peculiar conditions surrounding the teaching of language in Italy, where general concepts of the national language are affected by the existence of powerful dialects and the unstable nature of the grammar, vocabulary and syntax of the national literature. We have made no effort to find a writer worthy of being set up as a like authority, since no such problem exists for the American and English public. Our citations are drawn to a large extent from the "Book of Knowledge" and from a number of classics. Occasionally for special reasons we have translated the Italian original. The chapter on Italian metrics has been translated entire as an illustration of method; whereas the portion relating to English is, as explained below, entirely of speculative character.

To Miss Helen Parkhurst and Miss Emily H. Greenman thanks are due for the translation of the chapters on Arithmetic, Geometry, and Drawing.

CONTENTS

PART I

GRAMMAR

TRANSLATOR'S NOTE	vii
CHAPTER	PAGE
I. THE TRANSITION FROM THE MECHANICAL TO THE INTELLECTUAL DEVELOPMENT OF LANGUAGE	3
II. WORD STUDY	12
Suffixes and Prefixes	13
Suffixes	13
Prefixes	17
Compound Words	18
Word-Families	20
III. ARTICLE AND NOUN	22
Singular and Plural	25
Masculine and Feminine	27
Singular and Plural in English	33
IV. LESSONS—COMMANDS	39
Nouns	40
Commands on Nouns	48
V. ADJECTIVES	51
Analyses	51
Descriptive Adjectives	51
Permutations	55
Inflection of Adjectives	56
Logical and Grammatical Agreement of Nouns and Adjectives	59
Descriptive Adjectives	61
Adjectives of Quantity	63
Ordinals	64
Demonstrative Adjectives	64
Possessive Adjectives	65
Comparison of Adjectives	65

CHAPTER	PAGE
VI. VERBS	66
Analyses	66
Permutations	68
Lessons and Commands on the Verb	69
Lessons with Experiments	74
VII. PREPOSITIONS	77
Analyses	77
Permutations	80
Lessons and Commands on Prepositions	81
VIII. ADVERBS	85
Analyses	85
Permutations	87
Lessons and Commands on Adverbs	90
A Burst of Activity: the Future of the Written Lan- guage in Popular Education	93
Commands Improvised by the Children	96
IX. PRONOUNS	98
Analyses	98
Personals	98
Demonstratives	99
Relatives and Interrogatives	99
Possessives	101
Permutations	101
Lessons and Commands on the Pronoun	102
Paradymms	106
Agreement of Pronoun and Verb	108
Conjugation of Verbs	110
X. CONJUNCTIONS	113
Analyses	113
Coordinates	113
Subordinates	114
Permutations	115
Lessons and Commands on the Conjunction	115
Comparison of Adjectives	117
XI INTERJECTIONS	120
Analyses	120
Classification	122

CONTENTS

xiii

CHAPTER	PAGE
XII. SENTENCE ANALYSIS	124
Simple Sentences	124
The Order of Elements in the Sentence: Permutations	132
Compound and Complex Sentences	136
Test Cards	140
The Order of Clauses in the Sentence: Sentence Forms in Prose and Verse	144
Permutations	147
Test Cards	151
Coordinating and Subordinating Conjunctions	155
Sequence of Tenses	157
Punctuation	160
XIII. WORD CLASSIFICATION	164
Kinds of Words	164
Classified According to Formation	164
Classified According to Inflection	165
Classified According to Their Use	165

PART II

READING

I. EXPRESSION AND INTERPRETATION	171
Mechanical Processes	171
Analysis	173
Experimental Section: Reading Aloud	179
Interpretations	182
Audition	196
The Most Popular Books	198

PART III

ARITHMETIC

I. ARITHMETICAL OPERATIONS	205
Numbers 1-10	205
Tens, Hundreds and Thousands	208
Counting-frames	210
II. THE MULTIPLICATION TABLE	217

THIS PAGE IS LOCKED TO FREE MEMBERS

Purchase full membership to immediately unlock this page



HISTORY

Tens of thousands of important historical sources, many previously unobtainable, are now available for the first time with a Forgotten Books Full Membership.

Unlimited Access
\$8.99/month

Continue

*Fair usage policy applies

PART VI

MUSIC

CHAPTER	PAGE
I. THE SCALE	319
II. THE READING AND WRITING OF MUSIC	326
Treble and Bass Clefs	328
III. THE MAJOR SCALES	333
IV. EXERCISES IN RHYTHM	341
Singing	365
Musical Phrases for Rhythmic Exercises	367
V. MUSICAL AUDITIONS	376

PART VII

METRICS

I. THE STUDY OF METRICS IN ELEMENTARY SCHOOLS	383
Stanza and line	384
Rhyme	384
Tonic accents (stresses)	385
Parisyllabic lines	386
Imparisyllabic lines	388
The cæsura	391
Metrical analyses	392
Translator's note on English metrics	395
Material for nomenclature	404
APPENDIX I	409
APPENDIX II	423

ILLUSTRATIONS

	FACING PAGE
The first Montessori Elementary Class in America	<i>Frontispiece</i>
One of the first steps in grammar	24
Grammar Boxes, showing respectively two and three parts of speech	25
Grammar Boxes, showing respectively four and five parts of speech	78
Grammar Boxes, showing respectively six and seven parts of speech	79
Grammar Boxes, showing respectively eight and nine parts of speech	114
The children working at their various occupations in com- plete freedom	115
Interpreted reading: "Smile and clap your hands" . . .	174
Interpreted reading: "Take off your hat and make a low bow"	175
Interpreted reading: "Whisper to him"	188
Interpreting the pose and expression of a picture . . .	189
Interpreted reading: "She was sleepy; she leaned her arms on the table, her head on her arms, and went to sleep" .	200
Exercises in interpreted reading and in arithmetic . . .	201
The bead material used for addition and subtraction . .	214
Counting and calculating by means of the bead chains . .	214
The bead chain, square, and cube	215
The first bead frame	215
The second counting-frame used in arithmetic	226

	PAGE
Working out problems in seven figures	227
Solving a problem in long division	238
Bead squares and cubes; and the arithmetic-board for multiplication and division	239
The bead number cubes built into a tower	282
The decagon and the rectangle composed of the same triangular insets	283
The triangular insets fitted into their metal plates	283
Showing that the two rhomboids are equal to the two rectangles	288
Showing that the two rhomboids are equal to the two squares	289
Hollow geometric solids	296
Designs formed by arranging sections of the insets within the frames	297
Making decorative designs with the aid of geometric insets	312
Water-color paintings from nature	313
The monocord	334
Material for indicating the intervals of the major scale	334
The music bars	335
The children using the music bells and the wooden keyboards	352
Analyzing the beat of a measure while walking on a line	353

PART I
GRAMMAR

MONTESSORI ELEMENTARY MATERIAL

I

THE TRANSITION FROM THE MECHANICAL TO THE INTELLECTUAL DEVELOPMENT OF LANGUAGE

In the "Children's Houses" we had reached a stage of development where the children could write words and even sentences. They read little slips on which were written different actions which they were to execute, thus demonstrating that they had understood them. The material for the development of writing and reading consisted of two alphabets: a larger one with vowels and consonants in different colors, and a smaller one with all the letters in one color.

(In English, to diminish the phonetic difficulties of the language, combinations of vowels and consonants, known as phonograms, are used. The phonograms with few exceptions have constant sounds and little attention is paid to the teaching of the separate values of the different letters: not until the child has built up his rules inductively does he realize the meaning of separate vowel symbols.)

However, the actual amount of progress made was not very precisely ascertained. We could be sure only that the children had acquired the mechanical technique of

THIS PAGE IS LOCKED TO FREE MEMBERS

Purchase full membership to immediately unlock this page

Know Your Bible

Forgotten Books' Full Membership provides unlimited access to more than 28,000 volumes of Christian literature for \$8.99/month

**HOLY
BIBLE**

Continue

*Fair use policy applies

This only proves, however, that on beginning elementary grade work we did not depart from the "Children's House" idea; on the contrary we returned to it to give distinct realization to the nebulous hopes with which our first course concluded. Hence the "Children's House" and the lower grades are not two distinct things as is the case with the Fröbel Kindergarten and the ordinary primary school — in fact, they are one and the same thing, the continuation of an identical process.

Let us return then to the "Children's House" and consider the child of five and one-half years. To-day in those "Children's Houses" which have kept up with the improvements in our method the child is actually started on his elementary education. From the second alphabet of the "Children's House" we go on to a third alphabet. Here the movable letters are a great deal smaller and are executed in model hand-writing. There are twenty specimens of each letter, whereas formerly there were but four; furthermore, there are three complete alphabets, one white, one black, and one red. There are, therefore, sixty copies of each letter of the alphabet. We include also all the punctuation marks: period, comma, accents (for Italian), apostrophe, interrogation and exclamation points. The letters are made of plain glazed paper.

The uses of this alphabet are many; so before we stop to examine them let us look somewhat ahead. Everybody has recognized the naturalness of the exercise, used in the "Children's House," where the children placed a card bearing the name of an object on the object referred to. This was the first lesson in reading. We could see that the child knew how to read as soon as he was able to identify the object indicated on the card. In schools all over

6 MONTESSORI ELEMENTARY MATERIAL

the world a similar procedure would, I imagine, be considered logical. I suppose that in all the schools where the objective method is used much the same thing is done; and this is found to be not a hindrance but a help to the child in learning the names of objects. As regards the teaching of the noun, accordingly, we have been using methods already in use — the objective method, with practical exercises. But why should we restrict such methods to the noun? Is the noun not just as truly a *part of speech* as the adjective, or the verb? If there is a method by which the knowledge of a noun is made easy, may there not be similar ways of facilitating the learning of all the other parts of speech (article, adjective, verb, pronoun, adverb, interjection, conjunction, and preposition)?

When a slip with the interpreted word is placed on the object corresponding to it, the children are actually distinguishing the noun from all the other parts of speech. They are learning intuitively to define it. The first step has thus been taken into the realm of grammar. But if this “reading” has brought the child directly into word *classification*, the transition has not been for him so abrupt as might at first appear. The child has built *all* his words with the movable alphabet, and he has, in addition, *written* them. He has thus traversed a two-fold preparatory exercise involving, first, the analysis of the sounds and, second, the analysis of the words in their meaning. In fact, we have seen that, as the child reads, it is his discovery of the tonic accent that brings him to recognize the word. The child has begun to analyze not only the sounds and accent but also the form of the word.¹

¹ The process of learning to read has been more fully set forth in *The Montessori Method*: the child at first pronounces the sounds represented by the individual letters (phonograms), without under-

How absurd it would seem to suggest a study of phonology and morphology in a nursery with four-year-old children as investigators! Yet our children have accomplished this very thing! The analysis was the means of attaining the word. It was what made the child able to write without effort. Why should such a procedure be useful for single words and not so for connected discourse? Proceeding to the classification of words by distinguishing the noun from all other words, we have really advanced into the analysis of connected speech, just as truly as, by having the sand-papered letters "touched" and the word pronounced, we took the first step into the analysis of words. We have only to carry the process farther and perhaps we shall succeed in getting the analysis of whole sentences, just as we succeeded in getting at the composition of words — discovering meanwhile a method which will prove efficacious in leading the child to write his thoughts more perfectly than would seem possible at such a tender age.

For some time, then, we have been actually in the field of grammar. It is a question simply of continuing along the same path. The undertaking may indeed seem hazardous. Never mind! That "awful grammar," that horrible bugaboo, no less terrible than the frightful method, once in use, of learning to read and write, may perhaps become a delightful exercise, a loving guide to lead the child along pleasant pathways to the *discovery* of things he has *actually performed*. Yes, the child will suddenly find himself, one day, in possession of a little composition, a little "work of art," that has issued from standing what they mean. As he repeats the word several times he comes to read more rapidly. Eventually he discovers the tonic accent of the word, which is then immediately identified.

8 MONTESSORI ELEMENTARY MATERIAL

his own pen! And he will be as happy over it as he was when for the first time words were formed by his tiny hands!

How different grammar will seem to the young pupil, if, instead of being the cruel assassin that tears the sentence to pieces so that nothing can be understood, it becomes the amiable and indispensable help to "the construction of connected discourse"! It used to be so easy to say: "The sentence is written! Please leave it alone!" Why put asunder what God has joined? Why take away from a sentence its meaning, the very thing which gave it life? Why make of it a mere mass of senseless words? Why spoil something already perfect just for the annoyance of plunging into an analysis which has no apparent purpose? Indeed, to impose upon people who can already read the task of reducing every word to its primal sounds, would be to demand of them an effort of will so gigantic that only a professional philologist could apply himself to it with the necessary diligence, and then only because he has his own particular interests and aims involved in such work. Yet the four-year-old child, when he passes from those meaningless sounds to the composition of a whole, which corresponds to an idea and represents a useful and wonderful conquest, is just as attentive as the philologist and perhaps even more enthusiastic. He will find the same joy in grammar, if, starting from analyses, it gains progressively in significance, acquiring, step by step, a greater interest, working finally up to a climax, up to the moment, that is, when the finished sentence is before him, its meaning clear and *felt* in its subtlest essences. The child has created something beautiful, full grown and perfect at its birth, not now to be tampered with by anybody!

The analysis of sounds which, in our method, leads to spontaneous writing, is not, to be sure, adapted to all ages. It is when the child is four or four and a half, that he shows the characteristically childlike passion for such work, which keeps him at it longer than at any other age, and leads him to develop perfection in the mechanical aspect of writing. Similarly the analytical study of parts of speech, the passionate lingering over words, is not for children of all ages. It is the children between five and seven who are the *word-lovers*. It is they who show a predisposition toward such study. Their undeveloped minds can not yet grasp a complete idea with distinctness. They do, however, understand *words*. And they may be entirely carried away by their ecstatic, their tireless interest in the *parts* of speech.

It is true that our whole method was born of heresy. The first departure from orthodoxy was in holding that the child can best learn to write between the ages of four and five. We are now constrained to advance another heretical proposition: children should begin the study of grammar between the ages of five and a half and seven and a half, or eight!

The idea that analysis must be preceded by construction was a matter of mere prejudice. Only things produced by nature must be analyzed before they can be understood. The violet, for instance, is found perfect in nature. We have to tear off the petals, cut the flower into sections, to see how it grew. But in making an artificial violet we do just the opposite. We prepare the stems piece by piece; then we work out the petals, cutting, coloring, and ironing them one by one. The preparation of the stamens, even of the glue with which we put the whole together, is a distinct process. A few simple-minded peo-

10 MONTESSORI ELEMENTARY MATERIAL

ple, with a gift for light manual labor, take unbounded delight in these single operations, these wonderfully varied steps which all converge to the creation of a pretty flower; the beauty of which depends on the amount of patience and skill applied to the work on the individual parts.

Analysis, furthermore, is involved quite as much in building as in taking to pieces. The building of a house is an analytical process. The stones are treated one by one from cellar to roof. The person who puts the house together knows it in its minutest details and has a far more accurate idea of its construction than the man who tears it down. This is true, first, because the process of construction lasts much longer than that of demolition: more time is spent on the study of the different parts. But besides this, the builder has a point of view different from that of the man who is destroying. The sensation of seeing a harmonious whole fall into meaningless bits has nothing in common with the alternating impulses of hope, surprise or satisfaction which come to a workman as he sees his edifice slowly assuming its destined form.

For these and still other reasons, the child, when interested in words at a certain age, can utilize grammar to good purpose, dwelling analytically upon the various parts of speech according as the processes of his inner spiritual growth determine. In this way he comes to own his language perfectly, and to acquire some appreciation of its qualities and power.

Our grammar is not a book. The nouns (names), which the child was to place on the objects they referred to as soon as he understood their meaning, were written on cards. Similarly the words, belonging to all the other parts of speech, are written on cards. These cards are all

of the same dimensions: oblongs ($5 \times 3\frac{1}{2}$ cmm.) of different colors: black for the noun; tan for the article; brown for the adjective; red for the verb; pink for the adverb; violet for the preposition; yellow for the conjunction; blue for the interjection.

These cards go in special boxes, eight in number. The first box has two compartments simply; the second, however, three; the third, four; and so on down to the eighth, which is divided into nine. One wall in each section is somewhat higher than the others. This is to provide space for a card with a title describing the contents of the section. It bears, that is, the name of the relative part of speech. The title-card, furthermore, is of the same color as that used for the part of speech to which it refers. The teacher is expected to arrange these boxes so as to provide for the study of two or more parts of speech. However, our experiments have enabled us to make the exercises very specific in character; so that the teacher has at her disposal not only a thoroughly prepared material but also something to facilitate her work and to check up the accuracy of it.

THIS PAGE IS LOCKED TO FREE MEMBERS

Purchase full membership to immediately unlock this page



HISTORY

Tens of thousands of important historical sources, many previously unobtainable, are now available for the first time with a Forgotten Books Full Membership.

Unlimited Access
\$8.99/month

Continue

*Fair usage policy applies

tion. The exercises are easy for some children and very hard for others, nor is the order of selection the same among all the children. The teacher should know this material thoroughly. She should be able to recognize the favorable moment for presenting the material to the child. As a matter of fact, a little experience with the material is sufficient to show the teacher that the educational facts develop spontaneously and in such a way as to simplify the teacher's task in a most surprising manner.

SUFFIXES AND PREFIXES

Here we use charts with printed lists of words which may be hung on the wall. The children can look at them and also take them in their hands.

LIST I

SUFFIXES: AUGMENTATIVES, DIMINUTIVES, PEGGIORATIVES, ETC.

- buono (good)*: buonuccio, buonino, buonissimo
casa (house): casona, casetta, casettina, casuccia, casaccia, casettaccia
formica (ant): formicono, formicuccia, formicola, formichetta
ragazzo (boy): ragazzino, ragazzino, ragazaccio, ragazzetto
lettera (letter): letterina, letterona, letteruccia, letteraccia
campana (bell): campanone, campanello, campanellino, campanino, campanaccio
giovane (youth): giovanetto, giovincello, giovinastro
fiore (flower): fioretto, fiorellino, fioraccio, fiorone
tavolo (board): tavolino, tavoletta, tavolone, tavolaccio
seggiola (chair): seggiolone, seggiolina, seggiolaccia
pietra (stone): pietruzza, pietraina, pietrone, pietraccio
sasso (rock): sassetto, sassolino, sassettino, sassone, sassaccio
cesto (basket): cestino, cestone, cestello, cestellino
piatto (plate): piattino, piattello, piattone
pianta (plant or tree): piantina, pianticella, pianticina, pianterella, piantona, piantaccia

14 MONTESSORI ELEMENTARY MATERIAL

fuoco (fire): fuochetto, fuochino, fuocherello, fuocone, fuochettino

fiesta (festival): festicciola, festona, festaccia

piede (foot): piedino, piedone, pieduccio, piedaccio

mano (hand): manina, manona, manaccia, manuccia

seme (seed): semino, semetto, semone, semaccio, semettino

semplice (simple person): semplicino, semplicetto, sempliciotto, semplicione

ghiotto ("sweet-tooth"): ghiottone, ghiottoncello, ghiottaccio, ghiottissimo

vecchio (old man): vecchietto, vecchione, vecchiaccio, vecchissimo

cieco (blind): ciechino, ciechetto, ciecolino, ciecone, cieccaccio

Note:— The rôle of augmentative and diminutive suffixes in English is vastly less important than in Italian. Here are a few specimens:

lamb — lambkin

duck — duckling

bird — birdling

nest — nestling

goose — gosling

mouse — mousie

girl — girlie

book — booklet

brook — brooklet

stream — streamlet

poet — poetaster

The child's exercise is as follows: he composes the first word in any line with the alphabet of a single color (e.g., black). Next underneath and using the alphabet of the same color, he repeats the letters in the second word which he sees also in the first. But just as soon as a letter changes he uses the alphabet of another color (e.g., red). In this way the root is always shown by one color, the suffixes by another; for example:—

buono

buonuccio

buonino

buonissimo

For English:

stream
 streamlet
 lamb
 lambkin

Then the child chooses another word and repeats the same exercise. Often he finds for himself words not included in the list which is given him.

In the following chart the suffixes are constant while the root varies. Here the suffix changes the meaning of the word. From the original meaning is derived the word for a trade, a place of business, an action, a collective or an abstract idea. Naturally, the child does not realize all this at first but limits himself merely to building the words mechanically with the two alphabets. Later on, however, as grammar is developed, he may return to the reading of these charts, which are always at his disposal, and begin to realize the value of the differences.

LIST II

macello (slaughter)	macellaio (butcher)
sella (saddle)	sellaio (saddler)
forno (oven)	fornaio (baker)
cappello (hat)	cappellaio (hatter)
vetro (glass)	vetreria (glazery)
calzolaio (shoe-maker)	calzoleria (shoe-shop)
libro (book)	libreria (book-store)
oste (host)	osteria (inn)
pane (bread)	panetteria (bakery)
cera (wax)	cereria (chandler's shop)
dente (tooth)	dentista (dentist)
farmacia (pharmacy)	farmacista (druggist)
elettricit� (electricity)	elettricista (electrician)
telefono (telephone)	telefonista (telephone operator)
arte (art)	artista (artist)
bestia (beast)	bestiame (cattle)
osso (bone)	ossame (bones, <i>collective</i>)
corda (string)	cordame (strings, <i>collective</i>)
foglia (leaf)	fogliame (foliage)

16 MONTESSORI ELEMENTARY MATERIAL

pollo (chicken)
grato (grateful)
beato (blessed)
inquieto (uneasy)
grano (grain)
colombo (dove)
paglia (straw)
frutto (fruit)
canna (reed)
oliva (olive)
quercia (oak)

pollame (poultry)
gratitudine (gratitude)
beatitudine (blessedness)
inquietudine (uneasiness)
granaio (barn)
colombaio (dove-cote)
pagliaio (hay-stack)
frutteto (orchard)
canneto (brake)
oliveto (olive-grove)
querceto (oak-grove)

ENGLISH EXAMPLES

teach	teacher
sing	singer
work	worker
cater	caterer
wring	wringer
conduct	conductor
direct	director
launder	laundry
seam	seamstress
song	songstress
priest	priestess
mister	mistress
cow	cowherd
piano	pianist
art	artist
pharmacy	pharmacist
drug	druggist
physic	physician
prison	prisoner
house	household
earl	earldom
king	kingdom
count	county
real	reality
modern	modernness
good	goodness
sad	sadness
aloof	aloofness

The child's exercise with the two alphabets will be as follows:

frutto	frutteto	oliva	oliveto
canna	canneto	quercia	querceto

For English:

song	songster	songstress	
art	artist	artless	artful

LIST III

PREFIXES

nodo (knot): annodare, snodare, risnodare

scrivere (write): riscrivere, trascrivere, sottoscrivere, descrivere

coprire (cover): scoprire, riscoprire

gancio (hook): agganciare, sganciare, riagganciare

legare (bind): collegare, rilegare, allegare, slegare

bottone (button): abbottonare, sbottonare, riabbottonare

macchiare (spot): smacchiare, rismacchiare

chiudere (close): socchiudere, schiudere, richiudere, rinchiudere

guardare (look at): riguardare, traguardare, sogguardare

vedere (see): travedere, rivedere, intravedere

perdere (lose): disperdere, sperdere, riperdere

mettere (put, place): smettere, emettere, rimettere, permettere, commettere, promettere, sottomettere

vincere (overcome): rivincere, avvincere, convincere, stravin-
cere

For English:

cover: uncover, discover, recover

pose: impose, compose, dispose, repose, transpose

do: undo, overdo

place: displace, replace, misplace

submit: remit, commit, omit, permit

close: disclose, foreclose, reclose

arrange: rearrange, disarrange

18 MONTESSORI ELEMENTARY MATERIAL

The child's exercise with the two alphabets will be as follows:

coprire
scoprire
ricoprire

For English:

place
displace
replace

LIST IV

COMPOUND WORDS

cartapecora (parchment)	mezzaluna (half moon)
cartapesta (papier maché)	mezzanotte (midnight)
falsariga (guide)	palcoscenico (stage)
madreperla (mother-of-pearl)	acchiappacani (dog-catcher)
melagrana (pomegranate)	cantastorie (story-teller)
melarancia (orange)	guardaboschi (forester)
biancospino (hawthorn)	lustrascarpe (boot-black)
ficcanaso (busybody)	portalettere (letter-carrier)
lavamano (wash-stand)	portamonete (pocketbook)
mezzogiorno (noon)	portasigari (cigar-case)
passatempo (pastime)	portalapis (pencil-case)
ragnatela (cobweb)	portabandiera (standard bearer)
madrevite (vine)	guardaroba (wardrobe)
guardaportone (doorkeeper)	asciugamano (towel)
capoluogo (capital)	cassapanca (wooden bench)
capomaestro ("boss")	arcobaleno (rainbow)
capofila (pivot-soldier)	terrapieno (rampart, terrace)
capopopolo (demagogue)	bassorilievo (bas-relief)
caposquadra (commodore)	granduca (grand-duke)
capogiro (dizziness)	pianoforte (piano)
capolavoro (masterpiece)	spazzacamino (chimney-sweep)
giravolta (whirl)	pettorosso (redbreast).

For English:

sheepskin	redbreast
cardboard	appletree
shoestring	afternoon
midnight	moonlight
midday	starlight
noontime	doorknob

bedtime	bathroom
daytime	streetcar
springtime	lifelike
flagstaff	pocketbook
rainbow	inkwell
workman	tablecloth
housekeeper	courtyard
pastime	honeycomb
chimneysweep	beehive
sheepfold	flowerpot
barnyard	buttonhole
sidewalk	hallway
snowshoe	midway
shoeblack	storekeeper
firefly	horseman
steamboat	masterpiece
milkman	bookcase

The children read one word at a time and try to reproduce it from memory, distinguishing through the two alphabets the two words of which each one is composed:

carta pecora
bianco spino
piano forte

spazza camino
lava mano

For English:

moon light
work man

In the following chart the words are grouped in families. This chart may be used by children who are already well advanced in the identification of the parts of speech. All the words are derived from some other more simple word which is a root and of which the other words, either by suffix or prefix, are made up. All these roots are primitive words which some day the child may look for in a group of derivatives; and when he finds them he

THIS PAGE IS LOCKED TO FREE MEMBERS

Purchase full membership to immediately unlock this page

Know Your Bible

Forgotten Books'
Full Membership
provides unlimited
access to more than
28,000 volumes of
Christian literature for
\$8.99/month

**HOLY
BIBLE**

Continue

*Fair use policy applies

opera (work): operaio, operare, operazione, operoso, operosamente, cooperare, cooperazione, inoperare

canto (song): cantore, cantante, cantare, cantarellare, canticchiare, ricantare

gioco (game): giocare, giocattolo, giocarellare, giocatore, giocoso, giocosamente

dolore (pain): doloroso, dolorosamente, dolente, addolorare, dolersi, condolarsi, condoglianza, addolorato

pietra (stone): pietrificare, pietrificazione, pietroso, impietrire, pietraio

sole (sun): assolato, soleggiante, soleggiare

fiesta (festival): festeggiare, festino, festeggiatore, festeggiato, festaiolo, festante, festevole, festevolmente, festosamente

allegro (happy): allegria, allegramente, rallegrare, rallegramento

seme (seed): semina, semente, seminare, semenzaio, seminatore, riseminare, seminazione, disseminare, seminatrice

For English:

wood: wooden, woodworker, woody, woodsman, woodland

earth: earthen, earthy, earthly, earthborn, earthward, earthquake, earthling

fish: fishing, fisherman, fishery, fishy, fishmonger, fishnet

well: welcome, wellmeaning, wellknit

war: warrior, warlike, warship, warhorse, war-whoop, warsong, war-cry

play: player, playful, playhouse, playmate

politic: politics, politician, political, polity, politically

hard: hardly, harden, hardness, hardship, hardy, hardihood, hardware

turn: return, turner, turnstile

close: disclose, closet, unclose, closure, foreclose

The child sees that the mother word is always the shortest. The *root* remains in one color.

III

ARTICLE AND NOUN

[Note:—The English language presents a far simpler situation than the Italian as regards the agreement of article and adjectives. Gender itself being, in the case of English nouns, more a matter of logical theory than of word-ending, adjectival agreement in the formal sense is practically unknown to English grammar. Likewise the formation of the plural is much simpler in English than in Italian, where the singular and plural word-endings are closely associated with gender. It is a question, in fact, whether the whole subject of the gender of English nouns should not be taken up somewhat later in connection with the pronouns, where English shows three singular forms masculine, feminine, neuter (him, her, it) as against the Italian two, masculine and feminine (*lo, la*, plural *li, le*, etc.). Signora Montessori's discussion of the situation in Italian still remains instructive to the teacher of English as an illustration of method. We retain her text, accordingly, in its entirety.—Tr.]

As we have already said, the words chosen for grammatical study are all printed on small rectangular pieces of cardboard. The little cards are held together in packages by an elastic band and are kept in their respective boxes. The first box which we present has two compartments. In the holders at the back of each compartment are placed the cards which show the part of speech to be studied, in this case *article* and *noun*. The article cards are placed in the article compartment and the nouns in the noun compartment. When the children have fin-

ished their exercise they replace the cards — the nouns in the place for the nouns and the articles in the place for the articles. If the words *article* and *noun* are not a sufficient guide for the child, the color at least will make the task easy. In fact the child will place the black cards for the noun in the compartment indicated by the black guide-card (marked *noun*); the tan cards for the article with the tan guide-card (marked *article*). This exercise recalls the child's experience with the alphabet boxes, where one copy of each letter is pasted to the bottom of the box as a guide for the child in replacing the other letters. The child begins to speak of the *article-section*, the *noun-section*, and *article-cards* and *noun-cards*. In so doing he begins to *distinguish* between the parts of speech. The material must be prepared very accurately and in a definitely determined quantity. For the first exercise, the children are given boxes with the articles and nouns shuffled together in their respective compartments. But there must be just enough articles of each gender to go with the respective nouns. The child's task is to put the right article in front of the right noun — a long and patient research, which, however, is singularly fascinating to him.

We have prepared the following words. We should recall, however, that the cards are not found in the boxes in this order, but are mixed together — the articles shuffled in their box-section and the nouns in theirs.

il fazzoletto (the handkerchief)	i colori (the colors)
il libro (the book)	i fiori (the flowers)
il vestito (the dress)	i disegni (the drawings)
il tavolino (the <i>little</i> table)	i compagni (the companions)
lo specchio (the mirror)	gli zoccoli (the <i>wooden</i> shoes)
lo zucchero (the sugar)	gli uomini (the men)
lo zio (the uncle)	gli articoli (the articles)
lo stivale (the boot)	le sedie (the chairs)

24 MONTESSORI ELEMENTARY MATERIAL

la stoffa (the cloth)	le scarpe (the shoes)
la perla (the pearl)	le addizioni (the sums)
la piramide (the pyramid)	le piante (the plants, the trees)
la finestra (the window)	
l'occhio (the eye)	
l'amico (the friend)	
l'acqua (the water)	
l'albero (the tree)	
gl'invitati (the guests)	
gl'incastri (the insets)	
gl'italiani (the Italians)	
gl'insetti (the insects)	

(We suggest as a corresponding English exercise the introduction of the *indefinite* article. This substitution involves four processes against the eight of the Italian exercise. The use of *an* before a vowel is quite analogous to the problem of the Italian *l'* and *gl'*. However, the theoretical distinction between the definite and indefinite article, as regards meaning, is reserved by Signora Montessori to a much later period, though the practical distinctions appear in the earliest *Lessons and Commands*.— Tr.)

the handkerchief	the colors
the book	the flowers
the dress	the drawings
the table	the children
the mirror	the shoes
the sugar	the men
a man	an orange
a pearl	an apple
a prism	an uncle
a card	an eye
a window	an insect
a chair	an American
a tree	an aunt

The child tries to combine article and noun and puts them side by side on his little table. In this exercise he is



One of the first steps in grammar. The children are deeply interested in placing the correct articles and nouns together. (*A Montessori School in Italy.*)

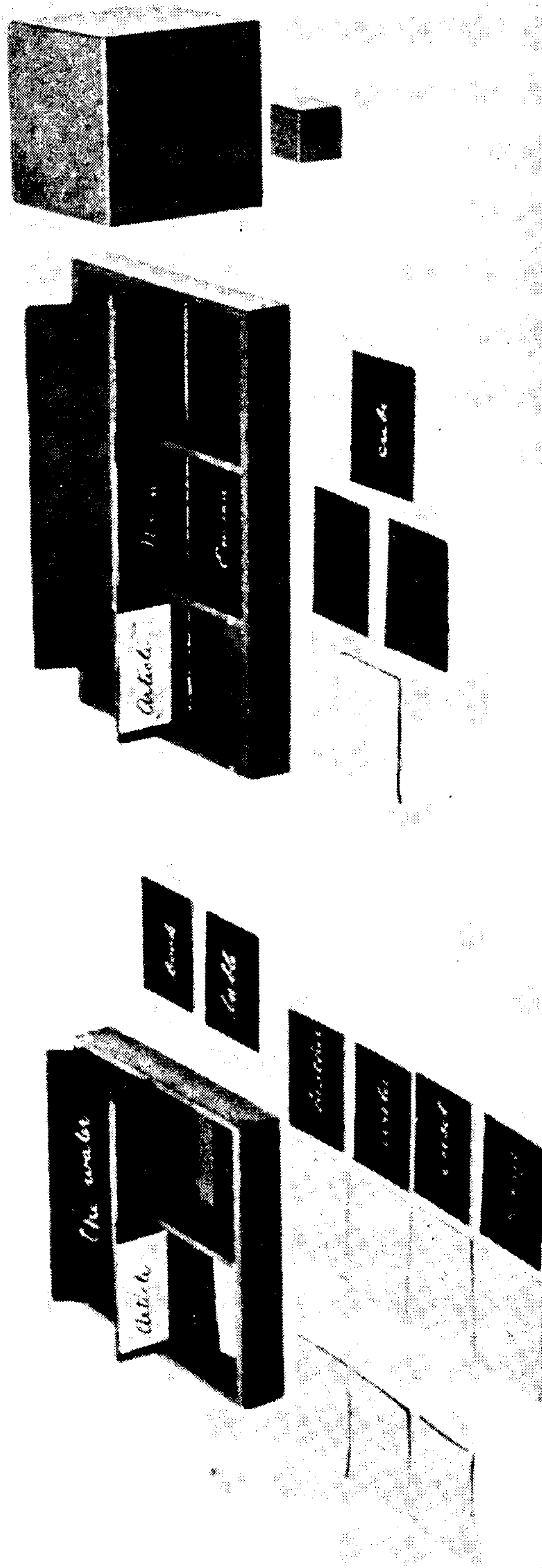

Grammar Boxes. The one on the left is for articles and nouns only; the one on the right, for articles, nouns, and adjectives.

guided by the
 the mind
 find relations
 sounds are
 revealed in
 these simple
 demonstrations
 very clearly
 forth in
 in his mind
 but the
 inner sense
 he perceives
 pride in the
 glance of
 but the
 the work
 gather them
 them
 This
 enthusiasm
 their
 tions
 to
 spirit
 sensation

The
 done
 have
 his

guided by sound just as he was in building words with the movable alphabet. There the child's first step was to find relationships between real objects and the linguistic sounds corresponding to them. Now he sees suddenly revealed to him hitherto unsuspected relationships between these sounds, these words. To have an empirical way of demonstrating and testing these relationships, to practise very thoroughly on two kinds of words, suddenly brought forth into systematic distinctness from the chaos of words in his mind, offers the child not only a necessary exercise but the sensation of relief which comes from satisfying an inner spiritual need. With the most intense attention he persists to the very end of the exercise and takes great pride in his success. The teacher as she passes may glance about to see if all the cards are properly placed, but the child, doubtless, will call her to admire or verify the work that he has done, before he begins to gather together, first, all the articles, then, all the nouns, to return them to their boxes.

This is the first step; but he proceeds with increasing enthusiasm to set the words in his mind "in order," thereby enriching his vocabulary by placing new acquisitions in an already determined place. Thus he continues to construct, with respect to exterior objects, an inner spiritual system, which had already been begun by his sensory exercises.

SINGULAR AND PLURAL

The exercises on the number and gender of nouns are done without the help of the boxes. The child already knows that those words are articles and nouns, so we give him now small groups of forty cards (nouns and articles) held together by an elastic band. In each one, the group

THIS PAGE IS LOCKED TO FREE MEMBERS

Purchase full membership to immediately unlock this page



HISTORY

Tens of thousands of important historical sources, many previously unobtainable, are now available for the first time with a Forgotten Books Full Membership.

Unlimited Access
\$8.99/month

Continue

*Fair usage policy applies

<i>Singolare</i>	<i>Plurale</i>	<i>Singular</i>	<i>Plural</i>
il piede	i piedi	the foot	the feet,
il quaderno	i quaderni	the copy book	etc.
la rapa	le rape	the turnip	
la scarpa	le scarpe	the shoe	
la tasca	le tasche	the pocket	
il tavolino	i tavolini	the table	
la testa	le teste	the head	
l'unghia	le unghie	the nail (finger)	

Like material has been prepared for the masculine and feminine forms: The masculine group is kept by itself, while the feminines are shuffled.

<i>Maschile</i>	<i>Femminile</i>	<i>Masculine</i>	<i>Feminine</i>
il conte	la contessa	the count	the countess,
l'amico	l'amica	the friend	etc.
l'asino	l'asina	the donkey	
il babbo	la mamma	the father	
il benefattore	la benefattrice	the benefactor	
il bottegaio	la bottegaia	the shop-keeper	
il cugino	la cugina	the cousin	
il cuoco	la cuoca	the cook	
il cacciatore	la cacciatrice	the hunter	
il cavallo	la cavalla	the horse	

<i>Maschile</i>	<i>Femminile</i>	<i>Masculine</i>	<i>Feminine</i>
il duca	la duchessa	the duke	the duchess,
il canarino	la canarina	the canary	etc.
il dottore	la dottoressa	the doctor	
il dattilografo	la dattilografa	the stenographer	
l'elefante	l'elefantessa	the elephant	
il figlio	la figlia	the son	
il fratello	la sorella	the brother	
il gallo	la gallina	the cock	
il gatto	la gatta	the cat	

<i>Maschile</i>	<i>Femminile</i>	<i>Masculine</i>	<i>Feminine</i>
il leone	la leonessa	the lion	the lioness,
l'ispettore	l'ispettrice	the inspector	etc.
il lupo	la lupa	the wolf	
il lettore	la lettrice	the reader	
il maestro	la maestra	the schoolmaster	
il marchese	la marchesa	the marquis	
il mulo	la mula	the mule	
il nonno	la nonna	the grandfather	
il nemico	la nemica	the enemy	

28 MONTESSORI ELEMENTARY MATERIAL

<i>Maschile</i>	<i>Femminile</i>	<i>Masculine</i>	<i>Feminine</i>
l'oste	l'ostessa	the host	the hostess,
l'orologiaio	l'orologiaia	the watch-maker	etc.
il poeta	la poetessa	the poet	
il pellicciaio	la pellicciaia	the furrier	
il padre	la madre	the father	
il re	la regina	the king	
il ranocchio	la ranocchia	the frog	
lo sposo	la sposa	the husband	
il servo	la serva	the man-servant	
il somaro	la somara	the ass	

Finally there are three series of nouns in four forms: Singular and Plural, Masculine and Feminine. Each group has eighty cards counting both nouns and articles, and the ten singular masculines in the guiding group are kept together, apart from the others. The title cards (twelve in number) are *singular* and *plural* and for each of them is a card marked *masculine* and a card marked *feminine*. The following is the order of the material when properly arranged by the child:

SINGOLARE		SINGULAR	
<i>Maschile</i>	<i>Femminile</i>	<i>Masculine</i>	<i>Feminine</i>
l'amico	l'amica	the friend	the friend,
il bambino	la bambina	the child	etc.
il burattinaio	la burattinaia	the puppet-player	
il contadino	la contadina	the peasant	
il cavallo	la cavalla	the horse	
il compagno	la compagna	the companion	
il disegnatore	la disegnatrice	the designer	
il dattilografo	la dattilografa	the stenographer	
l'ebreo	l'ebrea	the Jew	
il fanciullo	la fanciulla	the boy	

PLURALE		PLURAL	
<i>Maschile</i>	<i>Femminile</i>	<i>Masculine</i>	<i>Feminine</i>
gli amici	le amiche	the friends	the friends,
i bambini	le bambine	the children	etc.
i burattinai	le burattinaie	the puppet-players	
i contadini	le contadine	the peasants	
i cavalli	le cavalle	the horses	
i compagni	le compagne	the companions	

PLURALE		PLURAL	
<i>Maschile</i>	<i>Femminile</i>	<i>Masculine</i>	<i>Feminine</i>
i disegnatori	le disegnatrici	the designers	
i dattilografi	le dattilografe	the stenographers	
gli ebrei	l'ebree	the Jews	
i fanciulli	le fanciulle	the boys	

SINGOLARE		SINGULAR	
<i>Maschile</i>	<i>Femminile</i>	<i>Masculine</i>	<i>Feminine</i>
il gatto	la gatta	the cat	the cat,
il giardiniere	la giardiniera	the gardener	etc.
il giovinetto	la giovinetta	the youth	
l'infermiere	l'infermiera	the nurse	
l'italiano	l'italiana	the worker	
il lavoratore	la lavoratrice	the Italian	
il medico	la medichessa	the physician	
il materassaio	la materassaia	the mattress-maker	
l'operaio	l'operaia	the workman	
il pittore	la pittrice	the painter	

PLURALE		PLURAL	
<i>Maschile</i>	<i>Femminile</i>	<i>Masculine</i>	<i>Feminine</i>
i gatti	le gatte	the cats	the cats,
i giardinieri	le giardiniere	the gardeners	etc.
i giovinetti	le giovinette	the youths	
gl'infermieri	le infermiere	the nurses	
gl'italiani	le italiane	the Italians	
i lavoratori	le lavoratrici	the workers	
i medici	le medichesse	the physicians	
i materassai	le materassaie	the mattress-makers	
gli operai	le operaie	the workmen	
i pittori	le pittrici	the painters	

SINGOLARE		SINGULAR	
<i>Maschile</i>	<i>Femminile</i>	<i>Masculine</i>	<i>Feminine</i>
il ragazzo	la ragazza	the boy	the girl,
il romano	la romana	the Roman	etc.
lo scolare	la scolara	the scholar	
il sarto	la sarta	the tailor	
il santo	la tagliatrice	the saint	
il tagliatore	la donna	the cutter	
l'uomo	la vecchia	the man	
il vecchio	la visitatrice	the old man	
il visitatore	la zia	the visitor	
lo zio	la santa	the uncle	

30 MONTESSORI ELEMENTARY MATERIAL

PLURALE		PLURAL	
<i>Maschile</i>	<i>Femminile</i>	<i>Masculine</i>	<i>Feminine</i>
i ragazzi	le ragazze	the boys	the girls,
i romani	le romane	the Romans	etc.
gli scolari	le scolare	the scholars	
i sarti	le sarte	the tailors	
i santi	le sante	the saints	
i tagliatori	le tagliatrici	the cutters	
gli uomini	le donne	the men	
i vecchi	le vecchie	the old men	
i visitatori	le visitatrici	the visitor	
gli zii	le zie	the uncles	

Occasionally class exercises are used in our schools for the four forms of the Italian noun, masculine and feminine, singular and plural. They take the form almost of a game, which the children find amusing. A child for instance distributes around the class all the plural nouns. Then he reads aloud a noun in the singular. The child who holds the corresponding plural answers immediately. The same thing is next done for masculine and feminine, and, finally, for all four forms at once.

When these exercises have become familiar to the child, others somewhat more difficult may be presented. These new ones comprise: nouns which change form completely as they change gender and of which, so far, only the most familiar examples (*babbo*, "father," *mamma*, "mother," etc.) have been given (Series A); nouns in which the form is the same in the singular of both genders (Series B); those in which both genders have a common form in the singular and a common form in the plural (Series C); nouns which have only one form for both singular and plural (Series D); nouns where the same form appears in both genders but with a different meaning (Series E); finally, nouns which change gender as they pass from the singular to the plural (Series F).

SERIES A

SINGOLARE		SINGULAR	
<i>Maschile</i>	<i>Femminile</i>	<i>Masculine</i>	<i>Feminine</i>
il babbo	la mamma	the father	the mother
il becco	la capra	the he-goat	the she-goat
il frate	la suora	the friar	the nun
il fratello	la sorella	the brother	the sister
il genero	la nuora	the son-in-law	the daughter-in-law
il montone	la pecora	the ram	the ewe
il maschio	la femmina	the male	the female
il marito	la moglie	the husband	the wife
il padre	la madre	the father	the mother
il padrino	la madrina	the godfather	the godmother
il porco	la scrofa	the hog	the sow
il toro	la vacca	the bull	the cow
l'uomo	la donna	the man	the woman
il re	la regina	the king	the queen

PLURALE		PLURAL	
<i>Maschile</i>	<i>Femminile</i>	<i>Masculine</i>	<i>Feminine</i>
i babbi	le mamme	the fathers	the mothers,
i becchi	le capre	the he-goats	etc.
i frati	le suore	the friars	
i fratelli	le sorelle	the brothers	
i generi	le nuore	the sons-in-law	
i montoni	le pecore	the rams	
i maschi	le femmine	the males	
i mariti	le mogli	the husbands	
i padri	le madri	the fathers	
i padrini	le madrine	the godfathers	
i porci	le scrofe	the hogs	
i tori	le vacche	the bulls	
gli uomini	le donne	the men	
i re	le regine	the kings	

SERIES B

SINGOLARE		SINGULAR	
<i>Maschile</i>	<i>Femminile</i>	<i>Masculine</i>	<i>Feminine</i>
l'artista	l'artista	the artist	the artist,
il collega	la collega	the colleague	etc.
il dentista	la dentista	the dentist	
il pianista	la pianista	the pianist	
il telefonista	la telefonista	the telephone operator	
il telegrafista	la telegrafista	the telegraph operator	
il violinista	la violinista	the violinist	

32 MONTESSORI ELEMENTARY MATERIAL

PLURALE

<i>Maschile</i>	<i>Femminile</i>	<i>Masculine</i>
gli artisti	le artiste	the artists
i colleghi	le colleghe	the colleagues
i dentisti	le dentiste	the dentists
i pianisti	le pianiste	the pianists
i telefonisti	le telefoniste	the telephone operators
i telegrafisti	le telegrafiste	the telegraph operators
i violinisti	le violiniste	the violinists

PLURAL

Feminine
the artists,
etc.

SERIES C

SINGOLARE

<i>Maschile</i>	<i>Femminile</i>	<i>Masculine</i>
il consorte	la consorte	the husband
il custode	la custode	the keeper
il cantante	la cantante	the singer
l'erede	l'erede	the heir
il giovane	la giovane	the youth
l'inglese	l'inglese	the Englishman
il nipote	la nipote	the nephew (grandson)

SINGULAR

Feminine
the wife,
etc.

PLURALE

<i>Maschile</i>	<i>Femminile</i>	<i>Masculine</i>
i consorti	le consorti	the husbands
i custodi	le custodi	the guards
i cantanti	le cantanti	the singers
gli eredi	l'eredi	the heirs
i giovani	le giovani	the youths
gl'inglesi	le inglesi	the Englishmen
i nipoti	le nipoti	the nephews (grandsons)

PLURAL

Feminine
the wives,
etc.

SERIES D

<i>Singolare</i>	<i>Plurale</i>	<i>Singular</i>
il bazar	i bazar	the bazaar
il caffè	i caffè	the coffee
il gas	i gas	the gas
la gru	le gru	the crane
il lapis	i lapis	the pencil
la libertà	le libertà	the liberty
l'omnibus	gli omnibus	the omnibus
la virtù	le virtù	the virtue

Plural
the bazaars,
etc.

SERIES E

SINGOLARE		SINGULAR	
<i>Maschile</i>	<i>Femminile</i>	<i>Masculine</i>	<i>Feminine</i>
il melo	la mela	the apple tree	the apple
il pesco	la pesca	the peach tree	the peach
l'ulivo	l'uliva	the olive tree	the olive
il pugno	la pugna	the blow (punch)	the battle
il manico	la manica	the handle	the sleeve
il suolo	la suola	the floor	the sole

PLURALE		PLURAL	
<i>Maschile</i>	<i>Femminile</i>	<i>Masculine</i>	<i>Feminine</i>
i meli	le mele	the apple trees	the apples
i peschi	le pesche	the peach trees	the peaches
gli ulivi	le ulive	the olive trees	the olives
i pugni	le pugne	the blows (punches)	the battles
i manichi	le maniche	the handles	the sleeves
i suoli	le suole	the floors	the soles

SERIES F

<i>Singolare</i>	<i>Plurale</i>	<i>Singular</i>	<i>Plural</i>
il centinaio	le centinaia	the hundred	the hundreds,
il dito	le dita	the finger	etc.
la eco	gli echi	the echo	
il paio	le paia	the pair	
il riso	le risa	the smile (laugh)	
l'uovo	le uova	the egg	

THE SINGULAR AND PLURAL IN ENGLISH

TRANSLATOR'S NOTE:— While the formation of the English plural does not present the complications of gender that appear in Italian, the phonetic adaptations required by the plural ending -s along with certain orthographical caprices and historical survivals of the language, result in a situation somewhat more complex than that treated by Signora Montessori. In fact, her analysis of the Italian plural requires eight word-lists, while English requires at least fourteen, not including the question of foreign nouns. The special stress on the article is hardly necessary in English. An analogous treatment for English would be somewhat as follows:

THIS PAGE IS LOCKED TO FREE MEMBERS

Purchase full membership to immediately unlock this page

Know Your Bible

Forgotten Books'
Full Membership
provides unlimited
access to more than
28,000 volumes of
Christian literature for
\$8.99/month

**HOLY
BIBLE**

Continue

*Fair use policy applies

SERIES III

(Plurals of Nouns in -o)

LIST A

hero	heroes	motto	mottoes
mosquito	mosquitoes	domino	dominoes

LIST B

<i>Singular</i>	<i>Plural</i>	<i>Singular</i>	<i>Plural</i>
piano	pianos	dynamo	dynamos
soprano	sopranos	canto	cantos
zero	zeros	solo	solos
banjo	banjos	memento	mementos
halo	halos	chromo	chromos

SERIES IV

(Nouns in -f or -fe)

LIST A

<i>Singular</i>	<i>Plural</i>	<i>Singular</i>	<i>Plural</i>
calf	calves	shelf	shelves
elf	elves	thief	thieves
half	halves	leaf	leaves
loaf	loaves	self	selves
wolf	wolves		

LIST B

<i>Singular</i>	<i>Plural</i>	<i>Singular</i>	<i>Plural</i>
knife	knives	life	lives
wife	wives		

LIST C

<i>Singular</i>	<i>Plural</i>	<i>Singular</i>	<i>Plural</i>
staff	staffs	scarf	scarfs
wharf	wharfs	chief	chiefs
puff	puffs	fife	fifes
cliff	cliffs		

SERIES V

(Nouns in *-y*)

LIST A

<i>Singular</i>	<i>Plural</i>	<i>Singular</i>	<i>Plural</i>
body	bodies	soliloquy	soliloquies
sky	skies	sty	sties
gipsy	gipsies	Mary	Maries
berry	berries	ferry	ferries
penny	pennies	country	countries

LIST B

<i>Singular</i>	<i>Plural</i>	<i>Singular</i>	<i>Plural</i>
boy	boys	day	days
valley	valleys	derby	derbys

SERIES VI

(Plurals in *-en*)

<i>Singular</i>	<i>Plural</i>	<i>Singular</i>	<i>Plural</i>
child	children	brother	brethren
ox	oxen		(brothers)

SERIES VII

(Plurals with internal change (umlaut))

<i>Singular</i>	<i>Plural</i>	<i>Singular</i>	<i>Plural</i>
foot	feet	mouse	mice
tooth	teeth	man	men
goose	geese	woman	women
louse	lice		

SERIES VIII

(Singular and Plural identical)

<i>Singular</i>	<i>Plural</i>	<i>Singular</i>	<i>Plural</i>
sheep	sheep	deer	deer
fish	fish	swine	swine

SERIES IX
(Compound words)

LIST A

<i>Singular</i>	<i>Plural</i>
black-bird	black-birds
steamboat	steamboats
redcoat	redcoats
redbreast	redbreasts
forget-me-not	forget-me-nots
spoonful	spoonfuls
mouthful	mouthfuls

LIST B

<i>Singular</i>	<i>Plural</i>
brother-in-law	brothers-in-law
mother-in-law	mothers-in-law
court-martial	courts-martial
attorney-general	attorneys-generals
general-in-chief	generals-in-chief
Knight-Templar	Knights-Templar

All these groups of words in their order are reproduced in special booklets which the children may take home and read. In actual practise such books have proved both convenient and necessary. The children generally spend much time on them and delight in reading the words over and over in the order in which they themselves have discovered them in the card exercise. This recalls and fixes their own ideas, inducing a sort of inner maturation which is often followed by the spontaneous discovery of grammatical laws on the relations of nouns, or by a lively interest which throws the children into exclamations or laughter as they observe what great differences of meaning are sometimes caused by a very slight change in the word. At the same time these simple exercises, so fruitful in results, may be used for work at home and well meet the

38 MONTESSORI ELEMENTARY MATERIAL

demands for something to do with which children are continually assailing their parents. For homework we have prepared alphabets where the letters are printed in type-writing order. With them the child can compose words, or later, sentences, at the same time becoming familiar with the alphabet arrangement of standard typewriters.

IV

LESSONS — COMMANDS

The first lessons in grammar which I gave to children go back fully sixteen years. I first attempted the education of defectives in the "Scuola Magistrale Ortofrenica" in Rome in the year 1899 following a course of lectures I had given to teachers in the normal school of our capital. In this experiment I went far enough with primary work to prepare some of the defective children for successful examinations in the public schools. A very brief and incomplete summary of my pedagogical studies delivered in the teacher's courses is given in the appendix to this volume.

The teaching of grammar was not at that time so complete as it has since been made in my work with normal children; even so it was a marked success. Grammar was actually *lived* by the children, who became deeply interested in it. Even those wretched children who came, like rubbish thrown out of the public schools, directly off the street or from the insane asylums, passed delightful half hours of joyous laughter over their exercises in grammar. Here are some excerpts from the old pamphlet of 1900 giving an idea of the didactic material which was then used and some notion of a lesson on nouns. "As each word is read or written for every object-lesson, for every action, printed cards are being assembled which will later be used to make clauses and sentences with words that

may be moved about just as the individual letters were moved about in making the words themselves. The simple clauses or sentences should refer to actions performed by the children. The first step should be to bring two or more words together: e.g., *red-wool, sweet-candy, four-footed dog*, etc. Then we may go on to the sentence itself: *The wool is red; the soup is hot; the dog has four feet; Mary eats the candy*, etc. The children first compose the sentences with their cards; then they copy them in their writing books. To facilitate the choice of the cards, they may be arranged in special boxes: for instance, one box may be labeled *noun*: or the boxes may be distinguished thus: *food, clothing, animals, people*, etc. There should be a box for *adjectives* with compartments for colors, shapes, qualities, etc. There should be another for *particles*, with compartments for articles, conjunctions, prepositions, etc. A box should be reserved for *actions*, with the label *verbs* above it, and containing compartments for the infinitive, present, past and future. The children gradually learn by practise to take their cards from the boxes and put them back in their proper places. They soon learn to know their "word boxes" and they readily find the cards they want among the *colors, shapes, qualities*, etc., or among *animals, foods*, etc. Ultimately the teacher will find occasion to explain the meaning of the big words written at the top of the drawers, *noun, adjective, verb*, etc., and this will be the first step into the subject of *grammar*.

NOUNS

We may call persons and objects by their *name*, their *noun*. People answer if we call them, so do animals.

Inanimate objects, however, never answer, because they cannot; but if they could they would. For example, if I say *Mary*, *Mary* answers; if I say *peas*, the peas do not answer, because they cannot. You children *do* understand when I call an object and you *bring* it to me. I say, for example, *book*, *beans*, *peas*. If I don't tell you the name of the object, you don't understand what I am talking about; because every object has a different name. This *name* is the word that stands for the object. This name is a *noun*.

Whenever I mention a noun to you, you understand immediately the object which the noun represents: tree, chair, pen, book, lamb, etc. If I do not give this noun, you don't know what I am talking about; for, if I say simply *bring me at once, I want it*, you do not know what I want, unless I tell you the name of the object. Unless I give you the *noun*, you do not understand. Thus every object is represented by a word which is its *name*; and this name is a *noun*. To understand whether a word is a noun or not, you simply ask: *Is it a thing? Would it answer if I spoke to it? or Could I carry it to the teacher?* For instance, *bread*: yes, bread is an object; *table*: yes, it is an object; *conductor*: yes, the conductor would answer, if I were to speak to him.

Let us look through our cards now. I take several cards from different boxes and shuffle them. Here is the word *sweet*. Bring me *sweet*! Is there anything to answer when I call *sweet*? But you are bringing me a piece of candy! I didn't say *candy*: I said *sweet*. And now you have given me *sugar*! I said *sweet*! *Sweet*, you see, is not an object. You cannot guess what I have in mind when I say *sweet*. If I say *candy*, *sugar*, then you understand what I want, what object I am thinking about, be-

THIS PAGE IS LOCKED TO FREE MEMBERS

Purchase full membership to immediately unlock this page



HISTORY

Tens of thousands of important historical sources, many previously unobtainable, are now available for the first time with a Forgotten Books Full Membership.

Unlimited Access
\$8.99/month

Continue

*Fair usage policy applies

teacher's ingenuity; nor are they dependent solely upon her dramatic sense — something essential if she is to stimulate the weak nervous reactions of little defectives and so gain and hold their attention. The “commands” to-day are written and may be read. They are combined with the card-exercises where the cards are read in silence and interpreted through actions — a method which grew spontaneously and with such great success from the work in the “Children's House.” That is why, to-day, we speak in the elementary courses of “reading commands” or even of “writing commands.”

The study of grammar has finally been arranged in a methodical series of exercises and the material has been prepared after careful and rigid experiment. Those who read this method will get a clear idea of the teacher's task. She has a material ready for use. She need not bother to compose a single sentence nor to consult a single program. The objects at her disposal contain all that is necessary. She need know simply what they are and how they are to be used. The lessons which she must give are so simple, and require so few words, that they become lessons rather of gesture and action than of words. It must be borne in mind, further, that the work is not as uninteresting as would appear from this arid summary. The actual school is a real intellectual laboratory, where the children work all the time and by themselves. After the material has been presented to them, they *recognize* it and like to hunt for it. They know how to find for themselves the precious objects which they want to use. They often exchange materials and even lessons with other children. The few lessons the teacher gives connect, as it were, a system of live wires, which set in motion activities quite disproportionate to the energy expended in the sim-

ple act she performs. She pushes, so to speak, a button and here a bell rings, there a light goes on, there a machine begins to buzz. Very often the teacher sees a whole week go by without any need of intervention on her part.

And yet what delicacy and tact are necessary properly to "offer" this material, to give in an interesting way a lesson calculated to exert a direct action upon the child's spiritual activity! How skilful we must be to leave all the child's spontaneous impulses free to develop themselves, to keep careful watch over so many different individual impulses! This we must do if we are to "keep the lamp burning"! When, for example, on passing a table where the child has analyzed a sentence with the colored cards, the teacher shifts about, as if in play, one of the little slips, not only must she be possessed of the psychological insight necessary for intervening in this child's work at the proper time, but she must also have in mind the grammatical rule of which she wishes to give the child his first intuition. It follows that every single act of the teacher, however insignificant apparently, is, like the acts of the priest in the service, of the greatest importance, and should come from a consciousness thoroughly awake, and full of potentiality. Instead of giving out what she has in herself, the teacher must bring out the full possibilities of the children.

The teacher's extrinsic preparation is a matter of thorough acquaintance with the material. It should be so much a part of her that she knows at once what is needed for each individual case as soon as it arises. Actual practise soon develops this skill.

The exercises are performed with these little packages of specially prepared cards. The most important problem (for Italian grammar) is in the *agreements*; the agree-

ment of article and noun, as we have already shown, the agreement of noun and adjective, and later on of pronoun and verb, and pronoun and noun. There are two kinds of exercises, which we have termed respectively “analyses” and “commands.”

The *commands* involve both work done by the teacher and exercises performed by the children. The purpose here is to clarify the meanings of words and often to suggest a *practical* interpretation of them. This *explanation* is followed by an exercise of the children themselves, who in turn practically interpret the meaning of one or more sentences written on a card which they read just as they did in the first exercises of reading in the “Children’s House.” On this card are the words which the teacher has just explained. In our experiments we gave these lessons immediately after “silence” just as we did for reading in the “Children’s House.” All the children, however, do not necessarily take part in these executions — oftenest it is only a group of children, sometimes one child alone, again, at other times, almost all of them. If possible the commands are given in another room, while the other children continue their work in the large hall. If this is not possible it takes place in the same room. These commands might be called “an introduction to dramatic art,” for right there little dramatic scenes full of vivacity and interest are “acted out.” The children are singularly delighted in working for the one exact “interpretation” which a given word requires.

The *analyses*, on the other hand, are of quite different character. “Analysis” is done at the table. It is work which requires quiet and concentration. While the command gives the *intuition*, the analysis provides for the *maturation* of the idea. The grammar boxes are used in

these exercises. In a larger compartment which each box contains, are placed several slips bearing a printed sentence; for example, *Throw down your handkerchief*. The child draws a slip and places it to one side on the table. Then he takes from the different boxes the colored slips corresponding to the different words in the sentence and places them side by side one after the other. In this way he composes the entire sentence: *Throw down your handkerchief*. The child is actually doing here a very simple thing: he is merely translating into colored cards the sentence which is printed on his slip. He composes this sentence in the same way in which he has already composed words with the moveable alphabet. But here the exercise is even more simple because the child need not remember the sentence, for it is there right before his eyes. His attention must be concentrated on other facts, so that all intellectual effort in the composition of the sentence itself is eliminated. The child has to note the colors and the position of the cards in the different boxes, since he must take the cards now from the noun box, now from the adverb box, now from that of the preposition, etc.; and the colors together with the position (each section has a title, as we have already seen) strengthen his consciousness of a *classification* of words according to *grammar*.

But what really makes this exercise in analysis so interesting is the teacher's repeated permutation of the different cards. As she goes by a table she changes, as though in fun, the position of a card, and in this way provokes the intuition of grammatical rules and definitions. Indeed, when she takes out the card, which refers to some new part of the exercise, the remaining sentence with its changed meaning emphasizes the function of the part of speech which has been moved. The effect shows

a distant analogy to the light that pathology and vivisection throw on physiology. An organ which fails in its function illustrates exactly that function, for never does one realize the precise use of an organ more clearly than when it has lost its power of functioning. Furthermore the removal of the words demonstrates that the meaning of the sentence is not given by the word alone but by the *order* of the word in the sentence, and this makes a great impression on the child. He sees the same cards first in a chaotic mass and then in an orderly arrangement. What was first a collection of meaningless words has suddenly become the expression of a *thought*.

From now on the child begins to experience a keen interest in the *order* of words. The meaning, the only thing the child is after, is no longer hidden in confusion. He begins to enjoy subtle permutations, changes which, without destroying the expression of a thought, obscure its clarity, complicate it, or make it "sound wrong." It is here that the teacher must have at her fingertips the rules governing the position of the various parts of speech. This will give her the necessary "lightness of touch," perhaps even the opportunity of making some brilliant little explanation, some casual observation, which may suddenly develop in the child a profound "grammatical insight." When the child has understood this he will become a deep "strategist" in mobilizing, disposing and moving about these cards which express *thought*; and if he really succeeds in mastering this secret, he will not be easily satiated with so fascinating an exercise. No one but a child would ever have the patience to study grammar so profoundly and at such length. This subtle work is, after all, not so easy for the teacher. That is why the material must be such as to suggest each step in detail. The

teacher should be relieved as much as possible of the labor of preparation and research: for her delicate work of *intervention* is a task hard enough in itself. In preparing this material we have worked for her: we have acted as the workmen who produce the various objects necessary to life; she has but to “live” and “make live.” This will show still more clearly how far from truth is the modern conception of pedagogy which attempts to realize its desire for freedom in the school by saying to the teacher, “Try to respond to the needs of the pupils without being conscious of your authority over them.” When we ask a teacher to respond to the needs of the inner life of man, we are asking a great deal of her. She will never be able to accomplish it, unless we have first done something for her by giving her all that is necessary to that end. Here is our material:—

COMMANDS ON NOUNS

“CALLING”

Call loudly:

Mary! Lucy! Ethel!

Later call again:

Blonde! Beautiful! Good!

Call:

Peter! bring a chair.

George! bring a cube.

Louis! get a frame.

Charles! Charles! quick! bring me the . . . bring it to me, quick, quick.

Call slowly this way:

Come! Come! give me a kiss — please, come!

Then say:

Mary! come! give me a kiss!

These commands lend themselves to a little dramatic scene. It is really a sort of play, which the children recite.

The tendency to recitation and to imitation is very strong and often well developed at the age of five years. Little children experience a singular fascination in pronouncing the words with sentiment and in accompanying them with gestures. One can hardly imagine the simplicity of the little dramatic acts which interest the five year old child. Nothing but actual experiment could possibly have revealed it to us. One day, in fact, our little children were invited to be present at a dramatic entertainment given by the older children of the Public Schools. They followed it with really surprising interest. However, they remembered only three words of the play they had heard; but with these three words they made up a little dramatic action of their own, which they repeated over and over again the following day.

The commands of these "call" cards are, accordingly, real plays for our little ones. The child calls, pronouncing the name with a sort of sustained drawl; the child who is called comes forward; then the same thing is done with the other names, and each child obeys as he is called. Then the incomplete calls begin: *blonde! blonde! beautiful!* And no one moves! This makes a great impression on the children. Imperative commands, like requests, lend themselves to active dramatic action. Peter has been called and has brought his chair; George has brought the cube; Louis has taken out a frame; but Charles sits there intent, expectant, while the child calls out,—*But bring it to me, bring it to me quickly!* And how expressive we found the vain request,—*Come, come! please give me a kiss,—come, come!* At last the cry,—

THIS PAGE IS LOCKED TO FREE MEMBERS

Purchase full membership to immediately unlock this page

Know Your Bible

Forgotten Books' Full Membership provides unlimited access to more than 28,000 volumes of Christian literature for \$8.99/month

**HOLY
BIBLE**

Continue

*Fair use policy applies

ADJECTIVES

ANALYSES

MATERIAL: *Grammar box.*

Various objects already familiar to the children.

New objects.

The material for word analysis consists of small cards for articles (tan), nouns (black) and adjectives (brown). There is one box with three compartments, each section marked with a card bearing the respective title: *article, noun, adjective*. At the front of the box is a space for other cards containing printed sentences to be analyzed.

DESCRIPTIVE ADJECTIVES

The child is to read the sentences, find the objects described in them, and finally build the sentences with his cards as follows: suppose the card reads:

il colore verde

the green color

il colore turchino

the blue color

il colore rosso

the red color

The child finds the three colored tablets used in the familiar exercise of the "Children's House" for the education of the sense of color. He places these tablets on his table. Then he builds the phrases out of his word cards:

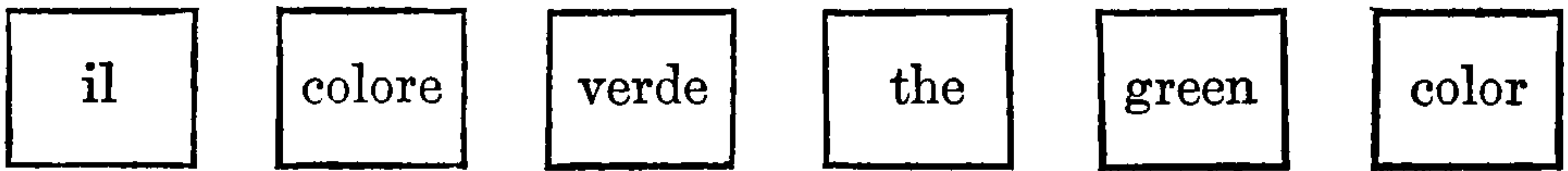

Beside the completed expression he places **the** green color-tablet. Passing to the next phrase, he does not disturb the words *the* and *color*. He removes only the word *green* and substitutes for it the adjective *blue*, at the same time removing the green tablet and substituting for it the blue. Similarly, for the third phrase, he changes the adjective, putting the red tablet at the end. Thus the *three different objects* were distinguished *only* by the adjective:

<i>il colore</i>	{	verde		{	green		<i>color</i>
		turchino			blue		
		rosso			red		

All the phrases and sentences refer to objects used in the previous educational material. Occasionally the teacher will have to prepare something herself (e.g., hot, cold, warm, or iced water; clear water; colored water). For this exercise on *water*, the box contains six slips with the six printed phrases. In the box-sections, the child finds the corresponding word-cards which are exactly in the number needed for the exercise (not corresponding, that is, to the number of words in the phrases, since the articles and nouns are not repeated). There are five groups of such exercises, dealing with various kinds of sensation.

A. SENSO CROMATICO

SENSE OF COLOR

il colore rosa
 il colore rosa scuro
 il colore rosa chiaro

the pink color
 the dark pink color
 the light pink color

il prisma azzurro
 il prisma marrone

the blue prism
 the brown prism

A. SENSO CROMATICO	SENSE OF COLOR
il colore verde	the green color
il colore turchino	the blue color
il colore rosso	the red color
i lapis neri	the black pencils
i lapis colorati	the colored pencils
l'acqua colorata	the colored water
l'acqua incolora	the clear water
il colore giallo	the yellow color
il colore arancione	the orange color
B. SENSO VISIVO: DIMENSIONI	SENSE OF SIGHT: SIZE
l'asta lunga	the long staff
l'asta corta	the short staff
il cubo grande	the large cube
il cubo piccolo	the small cube
il cilindro alto	the tall cylinder
il cilindro basso	the short cylinder
il prisma marrone grosso	the thick brown prism
il prisma marrone fino	the thin brown prism
il rettangolo largo	the broad rectangle
il rettangolo stretto	the narrow rectangle
l'incastro solido	the solid inset
l'incastro piano	the plane inset
C. SENSO VISIVO: FORMA	SENSE OF SIGHT: SHAPE
il triangolo equilatero	the equilateral triangle
il triangolo isoscele	the isosceles triangle
il triangolo scaleno	the scalene triangle
il triangolo acutangolo	the acute-angled triangle
il triangolo ottusangolo	the obtuse-angled triangle
il triangolo rettangolo	the right-angled triangle
l'incastro circolare	the circular inset
l'incastro quadrato	the square inset
l'incastro rettangolare	the rectangular inset
la piramide quadrangolare	the quadrangular pyramid
la piramide triangolare	the triangular pyramid

54 MONTESSORI ELEMENTARY MATERIAL

C. SENSO VISIVO: FORMA

il prisma azzurro rettangolare
il prisma azzurro quadrangolare

la scatola cilindrica
la scatola prismatica

SENSE OF SIGHT: SHAPE

the blue rectangular prism
the blue quadrangular prism

the cylindrical box
the prismatic box

D. SENSO TATTILE: MUSCOLARE

la superficie piana
la superficie curva

la stoffa ruvida
la stoffa liscia

l'acqua calda
l'acqua fredda
l'acqua tiepida

l'acqua fredda
l'acqua ghiacciata

la tavoletta pesante
la tavoletta leggera

la stoffa morbida
la stoffa dura

SENSE OF TOUCH: MUSCULAR SENSE

the flat surface
the curved surface

the rough cloth
the smooth cloth

the hot water
the cold water
the warm water

the cold water
the iced water

the heavy black-board
the light black-board

the soft cloth
the hard cloth

E. SENSO UEDITIVO; OLFATTIVO; GUSTATIVO

il rumore forte
il rumore leggero

il suono acuto
il suono basso

l'acqua odorosa
l'acqua inodora

l'odore buono
l'odore cattivo

il sapore amaro
il sapore dolce

il sapore acido
il sapore salso

SENSSES OF HEARING; SMELL; TASTE

the loud noise
the faint noise

the sharp sound
the deep sound

the fragrant water
the odorless water

the good smell
the bad smell

the bitter taste
the sweet taste

the sour taste
the salty taste

The teacher who is observing notices whether the child has taken the right objects; if so, she proceeds to the permutations.

PERMUTATIONS

At this point, the teacher should recall (in dealing with Italian) the grammatical rules for the position of adjectives, some of which (the fundamental ones) will certainly be very useful to her in executing these first permutations: —

I. In general, the adjective follows the noun. If placed before the noun, it is less conspicuous; if placed after, it assumes more importance and has a different force.

II. When the adjective is used to signify the exclusive superlative of a quality, it is not only placed after the noun, but is preceded by the article. (*Umberto il buono*, “Humbert the Good.”)

Example: — The child has composed the following phrase with his cards: *il triangolo rettangolo* “the right-angled triangle.” The teacher can interchange the words thus: *il rettangolo triangolo*, “the triangle right-angled.” Similarly also, for other phrases: —

<i>il prisma rettangolare azzurro</i>	the rectangular blue prism
<i>il rettangolare azzurro prisma</i>	the prism, rectangular, blue
<i>i lapis neri</i>	the black pencils
<i>i neri lapis</i>	the pencils black
<i>il colore rosso</i>	the red color
<i>il rosso colore</i>	the color red

Both the meaning and the child’s habits show him the normal position of the adjective. In some phrases, such as,

<i>il rumore leggero</i>	the faint sound
<i>il sapore dolce</i>	the sweet taste

the placing of the adjective before the noun renders the meaning vague, figurative, emotional, or generic, whereas it would be clearly descriptive and precise were the adjective in its normal position:

il dolce sapore	the taste sweet
il leggero rumore	the noise faint

(In English the normal position of the adjective is before the noun. The permutation develops a strong rhetorical flavor, of which the child will become conscious later in his studies on poetic inversions.—Tr.)

After the teacher has made these changes, if they have interested the child, she may say for example: “The adjective comes after its noun” (for Italian); “The adjective comes before its noun” (for English). In this way she will have given a lesson in *theoretical* grammar.

INFLECTION OF ADJECTIVES

(Exclusively for the Italian language)

Another exercise to be done at the table deals with the formation of the singular and plural of adjectives in the two genders. This exercise brings the child in contact with a great many adjectives of quality. Two series, one of twenty masculine, the other of twenty feminine adjectives (in the two numbers) and two other series, twenty singulars and twenty plurals (in the two genders), form four groups of cards, one-half of which (tied separately) serves to direct the placing of the other half. Here are the words in their groups:

<i>Singolare</i>	<i>Plurale</i>	
acuto	acuti	sharp
allegro	allegri	joyous
attenta	attente	careful, attentive

<i>Singolare</i>	<i>Plurale</i>	
basso	bassi	low
buona	buone	good
caldo	caldi	hot
cattiva	cattive	bad
dolce	dolci	sweet
duro	duri	hard
educata	educate	educated, well mannered
felice	felici	happy
fredda	fredde	cold
grande	grandi	large
grazioso	graziosi	graceful, pretty
gioiosa	gioiose	merry
gentile	gentili	kind
italiano	italiani	Italian
rabbioso	rabbiosi	angry
largo	larghi	broad
lento	lenti	slow
malata	malate	ill
odorosa	odorose	fragrant
arioso	ariose	airy
prezioso	preziosi	precious
piena	piene	full
pesante	pesanti	heavy
pulito	puliti	clean
rozza	rozze	rough, uncouth
rosso	rossi	red
robusta	robuste	robust
sincero	sinceri	sincere
studioso	studiosi	studious
stretto	stretti	narrow
stupida	stupide	stupid
vecchia	vecchie	old
morbido	morbide	soft
leggiera	leggiere	light (weight)
lunga	lunghe	long
grosso	grossi	thick
colorita	colorite	colored

THIS PAGE IS LOCKED TO FREE MEMBERS

Purchase full membership to immediately unlock this page



HISTORY

Tens of thousands of important historical sources, many previously unobtainable, are now available for the first time with a Forgotten Books Full Membership.

Unlimited Access
\$8.99/month

Continue

*Fair usage policy applies

<i>Maschile</i>	<i>Femminile</i>	
obbediente	obbediente	obedient
contenti	contente	content, happy
allegro	allegra	joyous

Here, just as with the four noun forms (masculine, feminine, singular and plural), class games may be found useful. The plural forms may be dealt out to the class, while one child reads aloud the singulars, one after the other. The child, who, in a given case, has the proper plural, reads his card in answer. Similarly, for masculine and feminine.

LOGICAL AND GRAMMATICAL AGREEMENT OF NOUNS AND ADJECTIVES

(For Italian Exclusively)

Another table exercise consists in arranging two groups of fifty cards, of which twenty-five are nouns (constituting the directing group), while the other twenty-five are adjectives. The nouns are put in a row and the child looks among the adjectives (which have been thoroughly shuffled) for those which are best suited to the different nouns. As he finds them he places them by the nouns with which they belong. Sometimes the nouns and adjectives placed together cause a great deal of merriment by the amusing contrasts that arise. The children try to put as many adjectives as possible with the same noun and develop in this way the most interesting combinations. Here are two groups which come prepared with the material:

60 MONTESSORI ELEMENTARY MATERIAL

<i>Nome</i>	<i>Aggettivo</i>	<i>Adjective</i>	<i>Noun</i>
contadina	allegra	happy	peasant-girl
casa	bella	beautiful	house
zia	brava	good	aunt
mamma	cara	dear	mother
professore	alto	tall	professor
maestra	magra	thin (lean)	teacher
lavandaia	pulita	neat	washerwoman
marinaio	robusto	strong	sailor
carrettiere	abbronzato	sunburnt	wagon-driver
bambino	buono	good	child
lavagnetta	rettangolare	square	slate
foglio	bianco	white	paper (sheet of)
panchetto	basso	low	bench
prisma	grosso	thick	prism
vaso	largo	broad	vase
foglia	verde	green	leaf
circolo	perfetto	perfect	circle
pizzicagnolo	grosso	fat	butcher
testa	unta	oily (dirty)	head
gomma	densa	hard, dense	rubber
fanciullo	stizzito	cross, angry	child
figlio	obbediente	obedient	son
pietra	nera	black	rock, stone
latte	bianco	white	milk
formaggio	tenero	soft, tender	cheese
carne	fresca	fresh	meat
vino	rosso	red	wine
disegno	grazioso	pretty	drawing
perla	lucente	shining	pearl
vetro	trasparente	transparent	glass
ragazzina	impertinente	impertinent	lass
asino	paziente	patient	donkey
gallina	grassa	fat	hen
topo	agile	quick, nimble	mouse
acqua	limpida	clear	water
saponetta	odorosa	perfumed, fragrant	soap
medico	bravo	good	doctor
giardiniere	bizzarro	surly	gardener
cane	arrabbiato	mad	dog
manicotto	morbido	soft	muff
gatto	arruffato	ruffled	cat
colombo	viaggiatore	traveling (carrier)	pigeon
uomo	brontolone	grumbling	man
ragno	pericoloso	dangerous	spider
serpente	velenoso	poisonous	snake

<i>Nome</i>	<i>Aggettivo</i>	<i>Adjective</i>	<i>Noun</i>
medicina	amara	bitter	medicine
nonna	indulgente	indulgent, kind	grandmother
babbo	severo	strict	father
vespa	maligna	cruel	wasp
cassetto	ordinato	orderly	box

For a class game with these lists, the nouns may be placed on one table and the adjectives on another. Moving as during the "silence" lesson, each child selects first a noun, and then an adjective. When the selections have all been made, the pairs are read one after the other amid general enthusiasm.

DESCRIPTIVE ADJECTIVES

COMMANDS (*Individual Lessons*)

The study of the adjective may furnish occasion for giving the child a knowledge of physical properties (of substances) so far unknown to him. For example, the teacher may present a piece of transparent glass; a piece of black glass (or any opaque screen); a sheet of white paper with an oil stain. The child will see that through the *transparent* glass objects may be seen distinctly; that through the oil stain only the light is visible; that nothing at all can be seen through the *opaque* screen. Or she may take a small glass funnel and put into it a piece of filter paper, then a sponge, then a piece of waterproof cloth. The child observes that the water passes through the filter paper, that the sponge absorbs water, and that the water clings to the surface of the waterproof. Or take two glass gradulators and fill them with water to different heights. In the case of the graduator filled to the very top, the surface of the water is *convex*; in the other, it is *concave*.

The commands are printed on little slips of paper which

are folded and all held together by an elastic band with a series of brown cards containing the adjectives used in the commands. Here is the material prepared:

— Fill one graduated cylinder with water to the point of overflowing, and another not so full. Notice the form assumed by the surface of the water in each case and apply the proper adjective: *convex, concave*.

— Take various objects such as filter paper, cloth, a sponge, and see whether water can pass through them, applying the adjectives: *permeable, impermeable, porous*.

— Take a piece of clear glass, a sheet of black paper, a sheet of oiled paper; look at the light through them, applying the adjectives: *transparent, opaque, translucent*.

Object lessons demonstrating comparative weights may also be given by putting successively into a glass of water, oil, alcohol colored with aniline, a piece of cork, a little leaden ball (to be dropped). Then the command would be:

— Compare the weights of water and of colored alcohol; water and oil; water and cork; and water and lead. Then tell which is *heavier* and which is *lighter* than the other.

As an answer the child should give a little written exercise something like the following: *Water is heavier than oil, etc.* The children actually perform these little experiments, learning to handle graduated cylinders, funnels, filters, etc., and to pour the last drops of water very carefully so as to obtain the concave and convex surfaces. They acquire a very delicate touch in pouring the colored alcohol and oil on the water. Thus they take the first step into the field of practical science.

To continue the study of adjectives of quality, there is a series of commands relating to the comparative and superlative. An example of the comparative crept into these

experiments on weight. Here are additional commands where the little slip and the brown cards are kept together.

— Take the blue stairs or any other objects and put with each object the proper adjectives from the following list: *thick, thin, thickest* (Ital. *grossissimo*), *thinnest* (Ital. *finissimo*).

— Take the eight tablets of the color you like best, arrange them according to shades and apply the proper adjectives of quality from the following: *light, lightest, dark, darkest*.

— Take the series of circles in the plane insets, and pick out the circles which correspond to these adjectives: *large, small, intermediate*.

— Take the cloths or other objects adapted to these adjectives: *smooth, smoothest, rough, roughest, soft, softest*.

— Take the cubes of the pink tower or any other objects adapted to these adjectives: *large, largest, small, smallest*.

— Grade a number of objects according to weight so as to fit these adjectives to them: *heavy, heaviest, light, lightest*.

ADJECTIVES OF QUANTITY

COMMANDS (*Individual Lessons*)

Just as above, the slip is tied with the series of brown cards by an elastic band. Thus a group is formed. In our material the following three groups are available:

— Take the counters and make little piles which correspond in quantity to these adjectives: *one, two, three, four, five, six, etc.*

— Take the beads and make little piles of them to fit these adjectives: *few, none, many, some*.

— Decide first of all on some definite number of beads (two) and then make other little piles to fit these adjectives: *double, triple, quadruple, quintuple, sextuple, tenfold, half, equal*.

ORDINALS

(Individual Commands)

— Build the blue stair and on each step place the proper adjective from the following: *first, second, third, fourth, fifth, sixth, seventh, eighth, ninth, tenth.*

— Place the following adjectives on the different drawers of the cabinet, beginning with the top drawer: *first, second, third, fourth, fifth.*

— Differentiate between the drawers of the cabinet by the following adjectives, beginning with the lowest: *first, second, third, fourth, fifth.*

DEMONSTRATIVE ADJECTIVES

(Class Lessons)

As occasion may offer, the teacher may assemble a group of children and give them a few simple explanations on the meaning of certain words: *questo*, “this” (near us); *cotesto*, “that” (near you); *quello*, “that” (over there away from both of us). (Note: English lacks the demonstrative of the second person.)

Then she can distribute these commands which require collective actions of the class: —

— Gather in *that* (*codesto*) corner of the room near you; then all of you come over to *this* (*questo*) corner near me; then all of you run over to that (*quello*) corner over there.

— Choose one of your school-mates and tell him to put a box on *this* (*questo*) table; a small plate on *that* (*quello*) table over there.

— Tell one of your companions, pointing at the place, to put a green bead in *this* (*questo*) vase; a blue one in *that* (*codesto*) vase; a white one in *that* (*quello*) vase over there.

Arrange the children in groups in three different places in the room, and then give this command:

— Let *that* (quello) group over there take the place of *this* (questo) group. Let *that* (codesto) group break up, the children going back to their tables.

POSSESSIVE ADJECTIVES

(Class Lessons)

In like manner the teacher explains the meaning of the words *my*, *your*, *his*, *her*, etc. She may do this with a simple gesture. Here are the commands:

— Point out various objects saying: This is *my* slate; that is *your* slate; that (over there) is *her* slate.

— Point at the different seats, saying: That (over there) is *his* place, that is *your* place, and this is *my* place.

— Pass around the little baskets, saying: This is *my* basket. Whose is that other basket? Is it *your* basket? And this one? Ah, this one is *his* basket.

— Let us take a turn around the room and then return to *our* seats. *You* go to *your* seat and *they* will go to *their* seats. Then we will divide up our things. Let us put *our* things here and *their* things there. We will go to *your* seats and you go to *their* seats. Meanwhile they will get up and then come over here to take *our* places.

[Signora Montessori does not differentiate between the possessive *adjective* and the possessive *pronoun*; perhaps because there is in Italian no characteristic pronominal form. Strictly speaking the Italian predicate form *mio* (e.g., *Questo libro è mio*) is adjectival, while the form *il mio* (i.e., with the definite article) is pronominal (e.g., *Questo è il mio*). English has, however, the pronominal possessives: *mine*, *yours* (thine), *his*, *hers*, *ours*, *yours*, *theirs*, used also as predicate adjectives. The above exercise should therefore be repeated later under the subject of pronouns in a slightly different form.— TR.]

THIS PAGE IS LOCKED TO FREE MEMBERS

Purchase full membership to immediately unlock this page

Know Your Bible

Forgotten Books'
Full Membership
provides unlimited
access to more than
28,000 volumes of
Christian literature for
\$8.99/month

**HOLY
BIBLE**

Continue

*Fair use policy applies

For example: if the following sentences are written on the cards:

Close the door!

Lock the door!

on the corresponding cards will be found the words:

Lock }
Close } the door.

And so the child after he has composed his first sentence needs to change only one card (*lock* for *close*) for the second sentence. This brings out the force of the verb, showing that one sentence may be changed into another by indicating an entirely different action. The child performs the action and then on his table he builds the sentences with the cards. In the series we have prepared, the verbs are either synonyms or antonyms. Here is the material:

SERIES A

— Close the door
Lock the door

— Fold the paper
Unfold the paper

— Tie a knot
Untie a knot

— Open the book
Shut the book

— Spread your beads
Collect your beads

— Speak a word
Whisper a word

SERIES B

— Raise your hands
Lower your hands

— Touch the velvet
Feel the velvet

— Toss the ball
Throw the ball

— Write a short word
Erase a short word

— Show your right hand
Hide your right hand

— Draw a circle
Fill a circle

SERIES C

— Bring a chair
Drag a chair

— Lace a frame
Unlace a frame

68 MONTESSORI ELEMENTARY MATERIAL

— Raise your head
Bow your head

— Arrange the brown cards
Mix the brown cards

— Fill a glass
Empty a glass

— Roll the white handkerchief
Twist the white handkerchief

SERIES D

— Embrace your nearest schoolmate
Kiss your nearest schoolmate

— Cover your face
Uncover your face

— Gather your prisms
Separate your prisms

— Lift the red counter
Drop the red counter

— Borrow a black pencil
Lend a black pencil

— Smooth the white paper
Crumple the white paper

SERIES E

— Clench your two hands
Open your two hands

— Rub the table
Scratch the table

— Spread the large carpet
Fold the large carpet

— Pour the water
Spill the water

— Bend your left arm
Straighten your left arm

— Comb your hair
Part your hair

PERMUTATIONS

The teacher should have in mind the grammatical rules for the position of the verb in the sentence, to give the child a clear idea of its normal location before the direct object: “first the verb, then the object upon which it acts.”

Example:

Smooth the white paper.

The verb should, for the first permutation, be transferred to the end:

the white paper smooth.

Or, if you wish,

Arrange the brown cards.
the brown cards arrange.

When the verb is taken away entirely the action vanishes:

Lift } the red counter.
Drop }
the red counter.

Making all possible permutations, the child sees that only one order of words is capable of bringing a meaning out of the confusion:

Roll the white handkerchief.
the white handkerchief roll.
white the handkerchief roll.
white roll handkerchief the.

LESSONS AND COMMANDS ON THE VERB

The children take considerable delight in our verb lessons which develop through interpretations of actions. We use packs of red cards, tied with an elastic, each pack containing ten cards. The child executes the actions indicated on each card, one after the other. He may afterward copy the cards — an exercise specially attractive to very young children.

Examples:

- walk, sing, jump, dance, bow, sit, sleep, wake, pray, sigh.
- write, erase, weep, laugh, hide, draw, read, speak, listen, run.
- arrange, clean, dust, sweep, button, lace, tie, hook, greet, brush.
- comb, wash, wipe, embrace, kiss, smile, yawn, scowl, stare, breathe.

These are fairly common words, representing actions more or less familiar to the pupils. But this exercise is only an introduction to the real verb-lessons. For these the teacher selects, as subject for a lesson, a series of synonymous verbs. Their shades of meaning are taught

to the children by translating them into action, the teacher executing the action herself. She then distributes around the class commands making use of the verbs in question. There may be several copies of a given command if the pupils are very numerous. The child reads by himself the card he has received, executing the action from memory of what he has seen the teacher do. We have tested experimentally the Italian material (*i.e.*, the verbs in parentheses), as follows:

Subject:

lay, throw, toss, hurl (posare, gettare, lanciare, scagliare).

Commands:—

— Take a counter and *lay* it on the floor. Pick it up again and *throw* it on the floor.

— Roll your handkerchief into a ball. *Toss* it into the air. Pick it up again and *hurl* it against the wall.

— *Lay* your handkerchief carefully, very carefully, on the floor. Pick it up again and *throw* it on the floor. Make a ball of it and *hurl* it across the room. Pick it up and *toss* it into the air.

Subject:

lie, crouch, sit, rise (sollevare, alzare, levare).

Commands:—

— Go to the sofa and *lie* with your face to the wall. Now *rise*, go to your table and *sit* with head erect.

— *Rise* from your chair and *crouch* behind the table, as though you were playing hide-and-seek. *Rise* and go back to the sofa.

Subject:

open, close, lock, unlock (aprire, spalancare, chiudere, socchiudere, serrare, disserrare).

Commands:—

— Go to a window and *open* it a little; wait a moment and

then *close* it again. *Open* the window as wide as you can and *close* it immediately.

— Go to the door and *open* it wide. Then *close* the door gently. If the key is in the key-hole *lock* the door; but before you go away, *unlock* it again, so that everything is left just as you found it.

Subject:

breathe, inhale, exhale (respirare, sospirare, inspirare, espirare).

Commands: —

— Go to the window, open it, and *inhale* and *exhale* the fresh air five times. Then after a moment *inhale* once and hold your breath as long as you can. When you can hold your breath no longer, *exhale* as slowly as you can.

— Take a hand mirror and *breathe* upon the glass. What happens?

Subject:

hang, attach (appendere, affiggere, sospendere).

Commands: —

— *Hang* one of your best drawings on a hook in the room.

— *Attach* the drawing you like best with two pins to the wall near the door.

Subject:

cover, wrap, tie, undo (avvolgere, involgere, svolgere).

Commands: —

— Take a book, a string and a large piece of cloth. Lay the book on your table and *cover* it with the cloth.

— Take the cloth and *wrap* it around the book so that the book cannot be seen.

— *Tie* a string around the cloth so that the book will not fall out.

— *Undo* the bundle, and return each object to the place where you found it.

72 MONTESSORI ELEMENTARY MATERIAL

Subject:

turn, invert, revolve, whirl, reverse (volgere, capovolgere, rovesciare).

Commands: —

.— *Turn* a picture toward one of your school-mates so that he can see it clearly.

— *Invert* the picture, so that it will be upside down.

— *Reverse* the picture so that the back only can be seen by your school mate.

— *Revolve* the seat of the piano-stool as rapidly as you can.

— Stand with your back to the window and *turn* slowly on your heel till you face the window. *Whirl* on your heel completely around till you again face the window.

Subject:

breathe, blow, puff, pant (sbuffare, soffiare, alitare).

Commands: —

— Tear a large piece of paper into tiny bits on your table. *Blow* steadily upon the table till the pieces of paper are all on the floor.

— Pick up the pieces of paper and place them on the table. *Puff* three times upon them and see if they all fall to the floor. Gather up the pieces and throw them into the waste-basket.

— *Breathe* softly upon the back of your hand. What do you feel?

— *Blow* upon the back of your hand. What do you feel?

— *Puff* upon the back of your hand. What do you feel?

— *Pant* noisily as though you had been running a long way.

Subject:

murmur, mutter, whisper, speak, grumble (mormorare, sussurrare, brontolare).

Commands: —

— Ask one of your school-mates to listen carefully to what you say; then *murmur* a short sentence as though you were speaking to yourself.

— *Mutter* the same words in a louder voice and see whether he understands.

— *Whisper* the same words in the ear of one of two children. Then ask the other whether he has heard.

— *Grumble* the same words and watch how the two children look at you.

— *Speak* the same words aloud and as distinctly as you can. Do the children understand?

Subject:

touch, rub, graze (*toccare, tastare, palpare, sfiorare*).

Commands: —

— Go to your table and with your eyes shut *touch* it as though to recognize it.

— *Rub* the table with the tips of your fingers, bearing down as hard as you can. What do you feel?

— *Graze* the table with the tips of your fingers, trying not to touch it.

Subject:

spread, sprinkle, collect, scatter (*spargere, spruzzare, aspergere*).

Commands: —

— Take a box full of beads and *spread* them evenly around the center of your table. Then *collect* them in a pile in the center of the table.

— Take a handful of the beads and *scatter* them over the table. Return all the beads to the box.

— Take a glass of water and *sprinkle* two or three handfuls on a plant in the room.

Subject:

walk, stagger, march (*barcollare, dondolare, erigersi*).

Commands: —

— *Walk* naturally to the end of the room farthest from your table.

— *March* back to your seat as though you were keeping time to music.

THIS PAGE IS LOCKED TO FREE MEMBERS

Purchase full membership to immediately unlock this page



HISTORY

Tens of thousands of important historical sources, many previously unobtainable, are now available for the first time with a Forgotten Books Full Membership.

Unlimited Access
\$8.99/month

Continue

*Fair usage policy applies

with the vanilla. *Flavor* another glass of water with vinegar.

Subject:

dissolve, saturate, be in suspension (*sciogliere, fare la sospensione, saturare*).

Commands: —

— Place a spoonful of sugar in a glass of warm water and *dissolve* the sugar by stirring with a spoon. Is the water still clear?

— *Saturate* the water with sugar by continuing to add sugar and stirring till you can see the sugar at the bottom of the glass. Allow the water to rest a moment. Is the water still clear?

— Mix a spoonful of starch in the water. The water becomes white, since the starch does not *dissolve* but remains *in suspension* in the water.

Subject:

strain, filter (*decantare, filtrare*).

Commands: —

— Take the glass containing the water saturated with sugar and the one with the starch in suspension, and allow the starch and sugar to settle for some time, until the water is clear. Taste the water in each glass, and then *strain* each glass of water separately.

— *Filter* the water saturated with sugar and the water with the suspended starch. Then taste of each.

By the time all these commands have been executed, the child will have developed a keen desire to go on, becoming so interested in the meaning of verbs as not to require further commands to stimulate his study of these words. The most frequent question now is “How many verbs are there in the language?” “Are there more in other languages?” etc. To satisfy this new curiosity of the children we have dictionaries of synonyms and antonyms, and

word-charts. But meantime they have been building their own dictionaries. One by one they begin to own copy books (rubrics) with illuminated letters of the alphabet. Under the proper letter the child copies his words as fast as he learns them. We are still experimenting on the question of the exact amount of information that may successfully be offered to elementary school children of various ages and stages of development, with the word material required for the notions of natural history, physics and chemistry they may be expected to acquire. We can say, at this moment, simply that each experiment involves the use of a certain number of new words (nouns, adjectives and verbs), which are copied into the word-books (rubrics) as fast as they occur.

VII

PREPOSITIONS

ANALYSES

Here also the first exercise is to compose sentences analyzed with the colored cards. This grammar box has five compartments, each with a small title card of the color corresponding to the different parts of speech, red for the verb, black for the noun, brown for the adjective, tan for the article and *violet* for the *preposition*. In the compartment at the rear of the box are six cards with printed sentences. The colored cards do not correspond exactly to the number of words used in the sentences because the words of one sentence which are repeated in the next are not duplicated in the cards. In this case it is the change in preposition only which alters the meaning of the sentence. Here are the series of sentences, some of which the teacher may have used already in previous lessons (commands).

SERIES A

(Prepositions of space relations)

- Take the box *with* the colored beads. (con, senza, insieme con).
- Take the box *without* the colored beads.
- Take the box *together with* the colored beads.
- Place the prism *under* the cylinder. (sotto a, sopra a).
- Place the prism *upon* the cylinder.

THIS PAGE IS LOCKED TO FREE MEMBERS

Purchase full membership to immediately unlock this page

Know Your Bible

Forgotten Books' Full Membership provides unlimited access to more than 28,000 volumes of Christian literature for \$8.99/month

**HOLY
BIBLE**

Continue

*Fair use policy applies

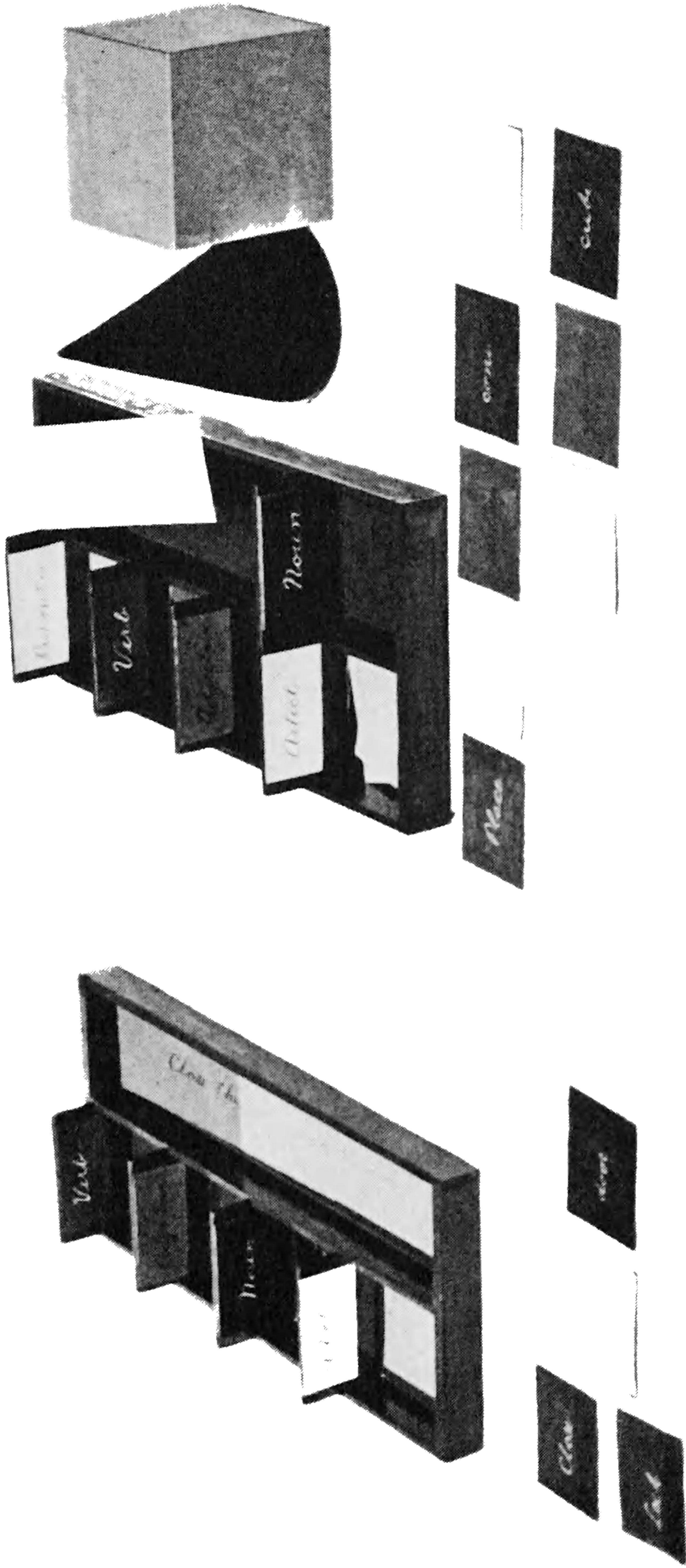

Grammar Boxes, showing respectively four and five parts of speech. (Note: The cards forming the sentence, "Place the blue cone against the pink cube," should have been arranged in one continuous line, not in two lines.)

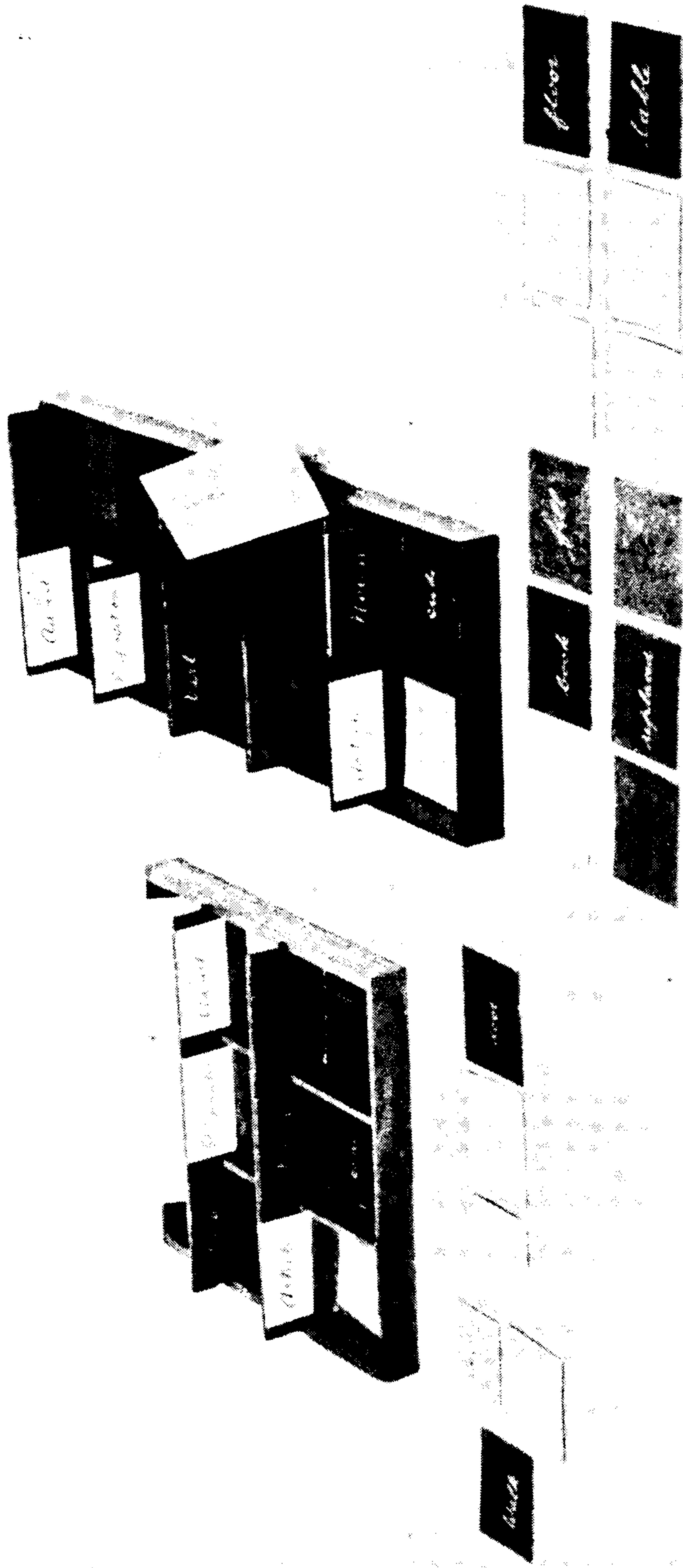

Grammar Boxes, containing respectively six and seven parts of speech. (Note: In the sentence on the right, the cards should be in one line, not two.)

possessive inflection with *-s*: *the drawing of George = George's drawing*. In Italian they are expressed by the prepositions *di, per, da*, etc.: *stoffa di cotone* "cotton cloth," *piattino di vetro* "glass saucer." For Signora Montessori's simple exercise we suggest for English the following definitions (Tr.)].

- Cotton cloth is cloth *of* cotton.
Woollen cloth is cloth *of* wool.
Silk cloth is cloth *of* silk.
- The iron triangle is a triangle *of* iron.
The wooden triangle is a triangle *of* wood.
- The glass saucer is a saucer *of* glass.
The china saucer is a saucer *of* china.
- A shoe-brush is a brush *for* shoes.
A clothes-brush is a brush *for* clothes.
- George's hat is the hat *of* George; George's hat belongs *to* George.
Mary's hat is the hat *of* Mary; Mary's hat belongs *to* Mary.
- A drinking-cup is a cup *for* drinking.
A copy-book is a book *for* copying.

SERIES D

(Direction and source of motion)

- Turn *from* the right *to* the left. (da...a, a...da)
Turn *from* the left *to* the right.
- Draw a line *from* the bottom of the paper *to* the top.
Draw a line *from* the top of the paper *to* the bottom.
- Go *from* your seat *to* the cabinet.
Go *from* the cabinet *to* your seat.
- Change the pen *from* your right hand *to* your left hand.
Change the pen *from* your left hand *to* your right hand.

THIS PAGE IS LOCKED TO FREE MEMBERS

Purchase full membership to immediately unlock this page



HISTORY

Tens of thousands of important historical sources, many previously unobtainable, are now available for the first time with a Forgotten Books Full Membership.

Unlimited Access
\$8.99/month

Continue

*Fair usage policy applies

Stretch a string from the door to the window.
 From the door to the window stretch a string.
 Stretch from the door a string to the window.
 From the door to the window a string stretch.
 From the door stretch to the window a string.

But the child will recognize that the right sentence is the simplest and the clearest:

Stretch a string from the door to the window.

On the other hand if we separate the preposition from its object or invert their normal position, the meaning is entirely lost:

Stretch a string the door from the window to.
 Stretch a string from the door window to the.
 String from the stretch door to the a window.

And likewise with these other sentences:

Run from the wash-stand to the table.
 Run wash-stand table (*definition of motion lacking*).
 Run wash-stand from the table to the.
 From the run wash-stand to the table.
 Wash-stand from the to the run table.

LESSONS AND COMMANDS ON PREPOSITIONS

The teacher may also take groups of children and give them short lessons on the preposition to explain the meaning, selecting if possible two or three synonyms or antonyms each time. The lessons should always be practical and full of action. The child should come to understand in this case the relationship established by this or that preposition between the object (noun) and the action (verb) to be performed. As soon as this has been made clear by the teacher the commands are distributed to the children who put them into execution. Here is the material that we use:

Subject:

Of (di).

Command:—

— Go and get a boxful *of* counters. Go and get a glass *of* water. Bring me a piece *of* cloth.

Subject:

near (to), next (to), beside, far away from (vicino, accosto, lontano).

Command:—

— One of you boys stand in the middle of the room. Now you others go and stand *near* him. One of you stand *next* to him on the right, another *beside* him on the left. Now all go *far away from* him.

Subject:

in, into, inside, out of (in, dentro, fuori).

Command:—

— Rise from your chairs and go *into* the next room. Stay *in* that room a moment and then come back *into* this one. Go back on tip-toe and lock yourselves *inside* the next room. Come *out of* the next room *into* this one.

Subject:

On this side of, on that side of, beyond (di là da, di qua da, oltre).

Command:—

— Leave your places and form a circle *on that side of* the door; form a circle then *on this side of* the door. All of you go and stand somewhere *beyond* the door.

Subject: :

except, save (tranne, eccetto).

Command:—

— All the children, *except* George and Mary, walk on tip-toe around the room.

— All the children, *save* George and Mary, walk on tip-toe around the room.

Subject:

side by side with, opposite, in front of, along (di fianco, di fronte, avanti).

Command: —

- Form a line *side by side with* each other.
- Form a line *along* the wall *opposite* the door.
- Form two lines *in front of* the piano.

Subject:

before, behind (dirimpetto, dietro).

Command: —

- Two of you come and stand *before* me.
- The rest of you go and stand *behind* me.

Subject:

on, about, along (su, secondo, lungo).

Command: —

— Each of you place one counter *on* the table. Now arrange the same counters *along* the far edge of the table. Now scatter the same counters *about* the center of the table.

Subject:

between, among (fra, in mezzo a).

Command: —

- One of you go and stand *between* the door and the piano.
- Place ten white counters on the table. Now go and scatter two or three red counters *among* the white ones.

Subject:

from, to, as far as (da, a, fino a).

Command: —

— Rise and walk *from* your places *to* the piano; wait a moment and then continue *as far as* the door of the next room.

Subject:

around, about (attorno, intorno).

Command: —

— Walk in couples, arm in arm, *around* the room twice; when

THIS PAGE IS LOCKED TO FREE MEMBERS

Purchase full membership to immediately unlock this page

Know Your Bible

Forgotten Books'
Full Membership
provides unlimited
access to more than
28,000 volumes of
Christian literature for
\$8.99/month

**HOLY
BIBLE**

Continue

*Fair use policy applies

VIII

ADVERBS

ANALYSES

Again the exercise consists of sentences analyzed by means of colored cards and commands. The grammar box contains six compartments having, like the others, the names of the different parts of speech on title cards of proper color. The card for the adverb is pink. In the rear compartment are six slips for each exercise, and in the sections the usual number of corresponding colored cards for the necessary words.

GROUP A

(Adverbs of Manner)

- Walk *slowly* to the window.
Walk *rapidly* to the window.
- Rise *silently* from your seat.
Rise *noisily* from your seat.
- Speak *softly* into the ear of your nearest comrade.
Speak *loudly* into the ear of your nearest comrade.
- Take five steps toward the door; turn *abruptly* to the left.
Take five steps toward the door; turn *gradually* to the left.
- Take your nearest comrade *lightly* by the arm.
Take your nearest comrade *roughly* by the arm.
- Look *smilingly* into the mirror.
Look *scowlingly* into the mirror.

GROUP B

(Adverbs of place and time)

- Place your pencil *there*.
Place your pencil *here*.
- Lay your book *somewhere* on the table.
Lay your book *elsewhere* on the table.
- Walk to the window *constantly* clapping your hands.
Walk to the window *occasionally* clapping your hands.
- Drink the water in the glass *now*.
Drink the water in the glass *by and by*.
- Carry the pink tower *upstairs*.
Carry the pink tower *downstairs*.
- Write a word on the blackboard *immediately*.
Write a word on the blackboard *soon*.

GROUP C

(Adverbs of quantity, comparison)

- Walk along the hall swinging your arms *somewhat*.
Walk along the hall swinging your arms *a great deal*.
- Bend your head *a little*.
Bend your head *much*.
- Walk *slowly* to the window.
Walk *less slowly* to the window.
Walk *more slowly* to the window.
- Place on the table your *most* beautiful drawing.
- Place on the table your beautiful drawing.
- Make a broad mark on the blackboard.
Make a *very* broad mark on the blackboard.

GROUP D

(Adverbs of comparison, correlative adverbs)

- Look for a piece of cloth softer *than* velvet.
- Look for a piece of cloth *as soft as* velvet.

- Find among your colors a shade *as* black *as* the blackboard.
- Find a piece of cloth *not so* shiny *as* satin.
- Find among the plane insets a rectangle *as* broad *as* half the square.
- Bring a rod longer *than* your copy-book.
- Bring a rod *as* long *as* your copy-book.
- Bring a rod *not so* long *as* your copy-book.
- Find a piece of cloth *less* rough *than* the canvas.

PERMUTATIONS

The sentences to be analyzed are reproduced as usual by building the first sentence on each slip; and then, by changing the adverb, the child gets the second or third sentence. One of the first permutations is to remove the adverb from those sentences where it performs the function of an *adjective to the verb*, thereby causing one action to be changed into another. For example take the two sentences:

Walk slowly to the window.

Walk rapidly to the window.

Taking away the adverb we have:

Walk to the window.

The child can perform the action which, now, is a simple one. The adverb, however, changes, *modifies*, the action. If the teacher in play puts the two adverbs together in the same sentence the child has the problem of interpreting two contrary movements. That is, he is to go to the window *slowly* and *rapidly* at the same time. Taking away the adverb cards the sentence left is *Go to the window*. This action the child can perform. But how shall he perform it, in what way? With the help of adverbs! Similarly in the following sentences:

THIS PAGE IS LOCKED TO FREE MEMBERS

Purchase full membership to immediately unlock this page



HISTORY

Tens of thousands of important historical sources, many previously unobtainable, are now available for the first time with a Forgotten Books Full Membership.

Unlimited Access
\$8.99/month

Continue

*Fair usage policy applies

quite foreign to normal Italian usage. We retain the text entire.)

In the sentences analyzed by the child it is sufficient to recall that the adverb modifies the verb and follows the verb it modifies. Take the sentence:

Bend your head a little as you write.

If the adverb is placed after the second verb the meaning changes:

Bend your head as you write a little.

The same is true in the following:

Walk along the hall swinging your arms somewhat.

Walk somewhat along the hall swinging your arms.

General shifting of position would give results as follows:

Bend a little your head as you write.

A little bend your head as you write, etc., etc.

Somewhat walk along the hall swinging your arms.

Walk along somewhat the hall swinging your arms, etc., etc.

The child is quick to recognize by ear the accurate, the normal position of the adverb.

On the other hand, adverbs of quantity and comparison precede the adjective:

Make a very broad mark on the blackboard.

Place on your table the prism that is least thick.

Permutation gives the following results:

Make a broad very mark on the blackboard.

Place on your table the prism which thick least is, etc., etc.

Adverbs of time and place often ring like trumpet calls to attention at the beginning of the sentence:

90 MONTESSORI ELEMENTARY MATERIAL

Drink the water in the glass now.

Now drink the water in the glass.

(Note: In English the adverb of time, placed at the end of the sentence, gains quite as much emphasis. So for adverbs of place.)

LESSONS AND COMMANDS ON ADVERBS

Subject:

straight, ziz-zag (diritto, a zig-zag).

Command: —

— Run *straight* into the other room; return to your place walking *zig-zag*.

Subject:

lightly, heavily, sedately (leggermente, gravemente, pesante-mente).

Command: —

— Walk *lightly* into the other room; return to your place walking *sedately* as though you were a very important person; walk across the room and back again resting *heavily* on each step as though it were hurting you to walk.

Subject:

suddenly, gradually (ad un tratto, gradatamente).

Command: —

— Form in line and walk forward beginning *suddenly* to stamp with your left foot. Return to your places letting the stamping *gradually* cease.

Subject:

meanwhile, frequently, occasionally (sempre, spesso, raramente).

Command: —

— Form in line and march slowly into the next room, stopping *frequently*. Return to your places stopping *occasionally*.

— Walk into the next room and back again, *meanwhile* keeping your eyes closed.

Subject: .

back, forward, to and fro (avanti, indietro, su e giù).

Command: —

— Form in line and walk *forward* to the other side of the room; then come *back* to your places.

— Walk *to and fro* across the room with your heads lowered and your hands behind your back.

Subject:

forwards, backwards.

Command: —

— Stand in the middle of the room; then walk *backwards* to the window, being careful to walk in a straight line. Return to your places walking *forwards*.

Subject:

slowly, abruptly (lentamente, bruscamente).

Command: —

— Rise *slowly* from your seats.

— Rise *abruptly* from your seats.

Subject:

politely, cordially (gentilmente, garbatamente).

Command: —

— Offer your chair *politely* to your nearest neighbor.

— Shake hands *cordially* with your nearest neighbor.

Subject:

alternately, in succession, simultaneously (successivamente, alternativamente, simultaneamente).

Command: —

— Raise your two hands *alternately* above your heads.

— Raise your two hands *simultaneously* above your heads.

— One of you children walk around the room bowing to each pupil *in succession*.

Subject:

Well, badly, fairly, best, worst (bene, male, meglio, peggio, così così, benino, maluccio, benissimo, malissimo).

THIS PAGE IS LOCKED TO FREE MEMBERS

Purchase full membership to immediately unlock this page

Know Your Bible

Forgotten Books'
Full Membership
provides unlimited
access to more than
28,000 volumes of
Christian literature for
\$8.99/month

**HOLY
BIBLE**

Continue

*Fair use policy applies

Subject:

crosswise, lengthwise.

Command: —

— Lay two rods *crosswise* on the table. Then lay them *lengthwise* on the table.

Subject:

sharply, sullenly, gently, kindly.

Command: —

— *Sharply* order your nearest neighbor to rise from his seat.

— Ask him *gently* to sit down again.

— Sit *sullenly* in your chair with your eyes lowered.

— Smile *kindly* at your nearest neighbor.

A BURST OF ACTIVITY:

THE FUTURE OF THE WRITTEN LANGUAGE IN POPULAR EDUCATION

In our own private experiments when we reached the adverb there occurred among the children a veritable explosion into a new kind of activity. They insisted on making up commands themselves. They invented them and then read them aloud to their companions or had their companions interpret the slips which they had written. All were most enthusiastic in performing these commands and they were rigorously scrupulous in acting them out down to the minutest detail. The executions came to be a literal, intensely real dramatization: if a word was inexact or incorrect, the interpretation of the command threw the error into noisy relief, and the child who had written it saw before him an action quite different from what he had in mind. Then he realized that he had expressed his thought wrongly or inadequately and immediately set to work to correct his mistake. The revelation seemed to redouble his energy. He would hunt

among his numerous words for the one necessary to translate his idea into a living scene before his eyes. Suppose a child had written the following sentence involving the use of the adverb *sempre* "always":

Walk about the room (*sempre*) *always* on tip-toe.

meaning that the child should *all the while* go on tip-toe; if the child began to walk on tip-toe and continued to do so for a long time, trying to express *sempre* (always — forever) he would find himself facing a serious problem. Hence the spontaneous query: "What must I do to express myself correctly?"

A little girl once wrote "Walk around the tables," meaning that the children should form a line and walk in and out around each table. Instead she saw her companions form a line and walk round the entire group of tables. Red in the face and out of breath she kept calling: "Stop, stop. That isn't the way," just as if this difference between the thought she actually had in mind and the way it was being executed were hurting her intolerably.

This is only a passing suggestion of something which, I think, will merit much further development later on, after more thorough experiment. It will suffice, however, to bring to the teacher a notion of a most fertile field for the development of the written language in its most rigorous purity. It is evident that the experiment shows the possibility not only of having spontaneous compositions without grammatical errors (just as the mechanical writing was spontaneous and without errors), but of developing a love for clearness and purity of speech which will be a potent factor in improving the literary appreciation of the masses, and popular culture generally.

When the children are seized with this passion for accurate expression of their thoughts in writing, when, spontaneously, clearness becomes the goal of their efforts, they follow the hunt for words with the keenest enthusiasm. They feel that there are never too many words to build with exactness the delicate edifice of thought. Problems of language come to them as a revelation. "How many words are there?" they ask. "How many nouns, how many verbs, how many adjectives? Is there any way for us to learn them all?" They are no longer content with their little copy-books of words. They ask for a wealth of word material which they now enjoy with all the delight of attractive and orderly interpretation. They never get tired of it.

These developments in our work suggested to us the idea of giving the children a large vocabulary comprising a sufficient number of nouns, verbs, and adjectives and containing *all* the words of the other parts of speech. The difference in bulk between the real content of language (substance and modification, that is, nouns with their adjectives, and verbs with their adverbs) and the other words which serve to establish relations and consolidate this content, is something very impressive to children of eight. It is for them that we tried to prepare our word charts and the dictionaries of synonyms for nouns, verbs, and adjectives. Here, meanwhile, are some of the commands which the children wrote themselves — things which they improvised all of a sudden, by an explosion of energy, as it were, developed as the result of inner maturity. Compare the aridity and uniformity of the commands we invented ourselves with the variety and richness of ideas appearing in the children's commands! We very evidently show the weariness the preparation

THIS PAGE IS LOCKED TO FREE MEMBERS

Purchase full membership to immediately unlock this page



HISTORY

Tens of thousands of important historical sources, many previously unobtainable, are now available for the first time with a Forgotten Books Full Membership.

Unlimited Access
\$8.99/month

Continue

*Fair usage policy applies

space; *there* form a circle; *next* a rhombus; *then* a square; *finally* a trapezium. Go into the big hall conversing *softly*; *suddenly* fall to the floor *lightly* and go to sleep; then wake up and look around, saying, "Where are we?" Then go back to your seats.

IX

PRONOUNS

ANALYSES

Material:— The box has seven compartments marked with the colored title slips; tan for the article, black for the noun, brown for the adjective, red for the verb, violet for the preposition, pink for the adverb, and *green* for the *pronoun*. In the rear space are the slips for the sentences to be analyzed. There are, as usual, fewer cards than words. The exercise is to substitute the pronouns for nouns.

GROUP A

(Personal Pronouns)

— George's sister was weeping. George soothed his sister with a kiss.

George's sister was weeping. *He* soothed *her* with a kiss.

— The book fell to the floor. Emma replaced the book on the table.

The book fell to the floor. *She* replaced *it* on the table.

— The children gave their mother a surprise. The children wrote a letter to their mother.

The children gave their mother a surprise. *They* wrote *her* a letter.

— The teacher said: The drawing is beautiful! Will *you* give the drawing to the teacher?

The teacher said: *It* is beautiful! Will *you* give *it* to *me*?

— Charles has gone into the other room. Can you find Charles?

Charles has gone into the other room. Can you find *him*?

GROUP B

(Demonstratives (questo, cotesto, quello) “this, that, these, those, this one, that one)

(As already noted for the adjective English lacks the demonstrative of the second person: that *near you*.)

— Show a child the prisms of the brown stair; *this* prism is thicker than *that* prism; *that* prism is thinner than *these* prisms.

Show a child the prisms of the brown stair; *this* is thicker than *that*; *that* is thinner than *these*.

— Let us look at the children: *this* child is taller than *that* child; *that* child is shorter than *this* child.

Let us look at the children: *this one* is taller than *that one*; *that one* is shorter than *this one*.

— Here is a cone on top of a cylinder: try to put the cylinder on top of the cone.

Here is a cone on top of a cylinder: try to put *this* on top of *that*.

— Let us show the cubes of the pink tower to a little girl: *this* cube is the largest; *those* cubes are the smallest of the series.

Let us show the cubes of the pink tower to a little girl: *this one* is the largest; *those* are the smallest of the series.

GROUP C

(Relatives and Interrogatives: (che, il quale, cui, chi? quale?) who, whom, whose, which, that, who? whose? whom? what? which? where, when?)

Note: The situation with the relatives is different in English: *who* refers to persons; *which* to things; *that* to either persons or things; whereas *che* and *il quale* are interchangeable referring to both

THIS PAGE IS LOCKED TO FREE MEMBERS

Purchase full membership to immediately unlock this page

Know Your Bible

Forgotten Books'
Full Membership
provides unlimited
access to more than
28,000 volumes of
Christian literature for
\$8.99/month

**HOLY
BIBLE**

Continue

*Fair use policy applies

- Select an inset from the insets used for drawing.
- Select an inset from *those which* are used for drawing.
- Select an inset from *those that* are used for drawing.

GROUP D

(Possessives: mine, yours, his, hers, ours, yours, theirs)

- | | |
|--|--|
| — This book is my book
This book is <i>mine</i> | — That house is our house
That house is <i>ours</i> |
| — This book is your book
This book is <i>yours</i> | — This money is your money
This money is <i>yours</i> |
| — Those pencils are his pencils
Those pencils are <i>his</i> | — Those seats are their seats
Those seats are <i>theirs</i> |
| — Those pencils are her pencils
Those pencils are <i>hers</i> | — This place is its place
This place is <i>its</i> |

PERMUTATIONS

The function of the pronoun as a substitute for a noun has been made clear in the analysis of the above sentences. After the children themselves have composed the first sentence with the colored cards they form the second sentence by taking away the noun card and substituting the corresponding pronoun. In the work done by the teacher to give the child an idea of the normal position of the pronoun, let her remember that in Italian personal pronouns precede the verb except in interrogation (where the subject may follow) and in cases where the subject is specially emphasized and where the pronouns appear as a suffix (infinitive, participle and imperative).

He soothed her with a kiss.

He her soothed with a kiss, etc., etc.

[It will become apparent that in English the personal pronoun takes the position of the noun, whereas for Italian the pronoun shifts to a position in front of the verb.

Considerable variety develops in English when the noun is replaced by a relative pronoun. However, the different problems arising in connection with pronouns generally are so complex that we return to this subject, especially to the question of subject and object forms, in dealing with sentence-analysis later.]

LESSONS AND COMMANDS ON THE PRONOUN

Subject:

Subjective Personal Pronouns: I, you, he, she, we, you, they (io, tu, egli, essa, noi, voi, loro, etc.).

Explain these pronouns as briefly and practically as possible from the point of view of speaker and listener, etc., one child commanding the others while they *execute* the command along with him. Example: The teacher, named for instance Anna Fedeli, explains in this way: "I don't say *Anna Fedeli*; I say *I*." "To Carlino here I don't say Carlino; I say, *you*." "Of Gigino, over there, I don't say Gigino; I say *he*," etc., etc.

Command: —

The command is given by a child; but he himself executes the first personal form along with the other children:

- | | |
|--|--|
| — <i>I</i> walk around the table | — <i>I</i> raise my arms |
| — <i>You</i> walk around the table | — <i>You</i> raise your arms |
| — <i>She</i> walks around the table | — <i>She</i> raises her arms |
| — <i>He</i> walks around the table | — <i>He</i> raises his arms |
| — <i>We</i> walk around the table | — <i>We</i> raise our arms |
| — <i>You</i> walk around the table | — <i>You</i> raise your arms |
| — <i>They</i> walk around the table | — <i>They</i> raise their arms |
| — <i>I</i> lift the chair | — <i>I</i> take the ink-stand |
| — <i>You</i> lift the chair | — <i>You</i> take the ink-stand |
| — <i>He</i> lifts the chair, etc., etc. | — <i>He</i> takes the ink-stand, etc.,
etc. |
| — <i>I</i> wave my handkerchief | |
| — <i>You</i> wave your handkerchief,
etc., etc. | |

From these exercises the notion gradually develops that:

the *first person* is the one who *speaks*;
 the *second person* is the one who *listens*;
 the *third person* is the one spoken of.

Other commands may be dramatized by small groups as follows:

— The first person must put a question the second must answer, and the third from a distance must try to hear both of them.

— Let the first one write, the second one watch, and the third one say “That is not right.”

The following commands may be read aloud by the child:

— *I* ask you a question very softly. *You* answer *me*; and *he*, over there, must try to hear both of us.

— *I* shall write; *you* must act as if you were trying to read what I am writing; and then *he*, over there, will call out: “That is not right.”

Subject:

Direct Objective Personal Pronouns: me, you, him, her, us, you, them (mi, ti, si, lo, la, ci, vi, si, li, le).

Reflexives and reciprocals: myself, yourself, etc., each other.

Command: —

(Here too one child commands executing the first personal forms, while the others act out the second and third):

— I touch the oil-cloth on the table; I touch *myself*; I touch *you*; you touch *yourself*; I touch *him*; you touch *her*; let us touch *each other*; you touch *me*.

— Charles, take the whisk-broom and brush the table; Charles, brush *me*; Charles, brush *him*; Charles, brush *her*; Charles, brush *yourself*.

— Mary and I bow to the teacher; now we bow to *you*; now we bow to *him*; now we bow to *her*; now we bow to *each other*.

THIS PAGE IS LOCKED TO FREE MEMBERS

Purchase full membership to immediately unlock this page



HISTORY

Tens of thousands of important historical sources, many previously unobtainable, are now available for the first time with a Forgotten Books Full Membership.

Unlimited Access
\$8.99/month

Continue

*Fair usage policy applies

—Point to two children, one standing near you and one far away; then command: *that one* (*colui*) go and fetch an arm-chair for *that one* (fem. *costei*) and a chair for *this one* (*questo*); then have him return to his place. Then have all the children execute the commands which *those* (*costoro*) will now give.

In case the class is made up either entirely of girls or entirely of boys, the children find considerable amusement in trying to imitate the manners of whichever opposite sex is missing.

Subject:

Demonstratives of things (*questo*, *cotesto*, *quello*, *ciò*, *ne*; here also English has no pronoun of the second person (*that near you*), nor does it possess the general indefinite *ciò* (referring to a general idea: *that* (*ciò*) *is true*).

When the meaning of these words, in terms of space location, has been taught, the children execute as follows:

Commands: —

— You children divide into three groups; then go and occupy three different places; change places as follows: you leave *that* (*cotesto*) and occupy *that* over there; the others leave *that* (*quello*) and occupy *this* (*questo*).

Subject:

Possessives: mine, yours (thine), his, hers, its, ours, yours, theirs.

Commands: —

— Point out various objects, saying: This is my slate; that one is *yours*, that is *hers*, and this one is *his*.

— Point at the different seats, saying: Here are our places, that is *mine* and this is *yours*. Those over there are *theirs*.

— Pass around little baskets, saying: This is my basket. Whose is that? Is that *yours*? Is this *hers*? Are these *ours*? Is this one *his*?

We dealt with the relatives only incidentally in the analyses (Group C above); we do not treat them here,

postponing the study of them in detail to the chapter on sentence-analysis.

PARADYMS

In teaching the declension of the pronouns we use the method employed by us in teaching all inflections: bundles of cards, of which one group is tied separately and serves as a guide. The child arranges the cards on the table, working first on the guiding group and putting the pronouns in order of persons: first, second, third.

GROUP A

(Personal Pronouns)

		<i>Masculine</i>		<i>Feminine</i>	
I	we	io	noi	io	noi
you, thou	you	tu	voi	tu	voi
he	they	egli	loro	ella	loro
she	they	esso	essi	essa	esse
it	they	lo	li	la	le
me	us	lui		lei	
you, thee	you	gli		le	
him	them				
her	them				
it	them				

GROUP B

(Demonstratives of Person)

		<i>Masculine</i>	<i>Feminine</i>
this	these	questi	costei
that	those	costui	costei
this one	these	colui	colei
that one	those	costoro	costoro
		coloro	coloro

GROUP C

(Demonstratives of Things)

		<i>Masculine</i>	<i>Feminine</i>
this	these	questo questi	questa queste
that	those	cotesto cotesti	cotesta coteste
this one	these	quel(lo) quegli, quei	quella quelle
that one	those	ciò	ciò
		ne	ne

GROUP D

(Relatives)

<i>Persons</i>	<i>Persons and Things</i>	
	<i>Masculine</i>	<i>Feminine</i>
who	il quale i quali	la quale le quali
whose	che	che
whom	chi	chi
that	cui	cui
<i>Things</i>		
which	chi (compound = "he who")	
that		
what (compound = that which)		

GROUP E

(Possessives)

mine	its
yours (thine)	ours
his	yours
hers	theirs

GROUP F

(Interrogatives)

<i>Persons</i>	<i>Persons</i>
who?	chi?
whose?	
whom?	quale?
which?	

THIS PAGE IS LOCKED TO FREE MEMBERS

Purchase full membership to immediately unlock this page

Know Your Bible

Forgotten Books' Full Membership provides unlimited access to more than 28,000 volumes of Christian literature for \$8.99/month

**HOLY
BIBLE**

Continue

*Fair use policy applies

GROUP C

io sento ("I hear")	io sentivo ("I was hearing")	io sentirò ("I shall hear")
tu senti	tu sentivi	tu sentirai
egli sente	egli sentiva	egli sentirà
noi sentiamo	noi sentivamo	noi sentiremo
voi sentite	voi sentivate	voi sentirete
essi sentono	essi sentivano	essi sentiranno

FOR ENGLISH

GROUP A

(Simple Tenses)

I love	I loved	I shall love
you love	you loved	you will love
he loves	he loved	he will love
we love	we loved	we shall love
you love	you loved	you will love
they love	they loved	they will love

GROUP B

(Progressive Forms)

I am loving	I was loving	I shall be loving
you are loving	you were loving	you will be loving
he is loving	he was loving	he will be loving
we are loving	we were loving	we shall be loving
you are loving	you were loving	you will be loving
they are loving	they were loving	they will be loving

GROUP C

(Interrogative Forms)

do I love?	did I love?	will I love?
do you love?	did you love?	shall you love?
does he love?	did he love?	will he love?
do we love?	did we love?	will we love?
do you love?	did you love?	shall you love?
do they love?	did they love?	will they love?

GROUP D

(Intensive and Negative Forms)

I do (not) love, etc.	I did (not) love etc.	I shall (not) love etc.
--------------------------	--------------------------	----------------------------

The child can shuffle his cards in various ways, mixing the verb forms of the three different Italian verbs, or the four tense forms of the English verb; passing then to a reconstruction of the different tenses according to the pronouns, the order of which has by this time become familiar to him.

The next step is to conjugate properly.

CONJUGATIONS OF VERBS

MATERIAL

In our material we offer (for Italian) the conjugation of the two auxiliary verbs (*essere* "to be," *avere* "to have") and the model verbs of the first, second and third conjugations. The colors used for the five verbs are all different, yellow for *essere* "to be," black for *avere* "to have," pink for *amare* "to love," green for *temere* "to fear," light blue for *sentire* "to hear." Each card has both pronoun and verb form. This is not only to simplify and expedite the exercise but also to make sure of auto-exercise, since the pronoun guides the order of the forms in each tense. These verb forms of a given verb preceded by the pronouns are, accordingly, made into a little package. Here, however, the groups are not so simple as in other cases. For the verb, the cards are kept in a sort of red envelope tied with a ribbon. The infinitive of the verb is written on the outside of the envelope, which, though very simple, is most attractive. When the whole verb is wrapped in its package and tied with the ribbon, it forms a small red prism of the following dimensions: cmm. $35 \times 4 \times 5.5$. On untying the ribbon and opening the envelope the child finds inside ten little "volumes" with red covers. These volumes represent the

moods of the verb and they have the following titles inscribed on the first page:

Indicative Mood
 Conditional Mood (for Italian)
 Subjunctive Mood
 Imperative Mood
 Verbals

To facilitate replacing these materials in an orderly way and to be sure that this order is recognized, the child finds in the corner of each envelope a Roman numeral (I, II, III, IV, V); and besides that, an Arabic numeral indicating the number of tenses in the given mood. On opening the little volume and taking off the cover we find many other tiny volumes with red covers. These are the tenses. In the middle of each cover is written the name and, to one side, the number indicating the relative position of the tenses in the following manner: the *simple* tense is marked with the letter *S* and the *compound* tense with the letter *C*. The titles, then, of the eight booklets contained in the little volume for a given mood are:

Present Tense 1s
 Past Tense 2s
 Future Tense 3s
 Perfect Tense 1c
 Pluperfect Tense 2c
 Future Perfect Tense 3c

(For Italian the tenses are: Present, 1s, Imperfect 2s, Remote Past 3s, Future 4s, Perfect 1c, Pluperfect 2c, Past Anterior 3c, Future Perfect 4c.)

Finally, on opening each of these little booklets (which, by the way, are 3.5×4 cmm. and only a bare millimeter thick) we have the cards with the verb forms preceded by the corresponding pronoun.

THIS PAGE IS LOCKED TO FREE MEMBERS

Purchase full membership to immediately unlock this page



HISTORY

Tens of thousands of important historical sources, many previously unobtainable, are now available for the first time with a Forgotten Books Full Membership.

Unlimited Access
\$8.99/month

Continue

*Fair usage policy applies

X

CONJUNCTIONS

ANALYSES

Material: This box has eight compartments for the title cards, which are tan (article), black (noun), brown (adjective), red (verb), violet (preposition), pink (adverb), green (pronoun), and *yellow* (*conjunction*). It also has the usual place for the sentences that are to be analyzed. These again are given in groups.

GROUP A

Coordinate Conjunctions

(Copulative, Disjunctive, Illative, Adversative)

— Put away the pen *and* the ink-stand.

Put away the pen *or* the ink-stand.

Put away *neither* the pen *nor* the ink-stand, *but* the paper.

— The table, therefore, is bare *and* in order.

For all your things are in their places.

— Do not leave the objects you use here and there about the room, *but* put them all back in their places.

— Speak to your nearest school-mate not aloud *but* in a whisper.

— Move your table forward a little, *but* only a little *and* without making any noise.

GROUP B

Subordinate Conjunctions

(Time, condition, cause, purpose)

- You can push down a key of the piano without making any sound *if* you push it down slowly.
- You could write with your left hand *if* you “touched” the letters with that hand.
- You will get silence from the children *as soon as* you write “silence” on the blackboard.
- That child is happy: he always sings *while* he works.
- Always shut the door *when* you go from one room to another.
- Everybody must be orderly *in order that* the “Children’s House” may look neat.

GROUP C

Subordinate conjunctions, *continued*

(Cause, concession, alternative)

- The “Children’s House” is attractive *because* it is pretty and *because* it is so easy to keep busy all the time.
- I shall give it to you *since* you have asked me for it very politely.
- We shall go to walk in the park rather *than* in the crowded streets.
- I shall give you that toy *although* I should have preferred to let you have a beautiful book.
- You may promise to go and visit him to-morrow *provided* you keep your promise.

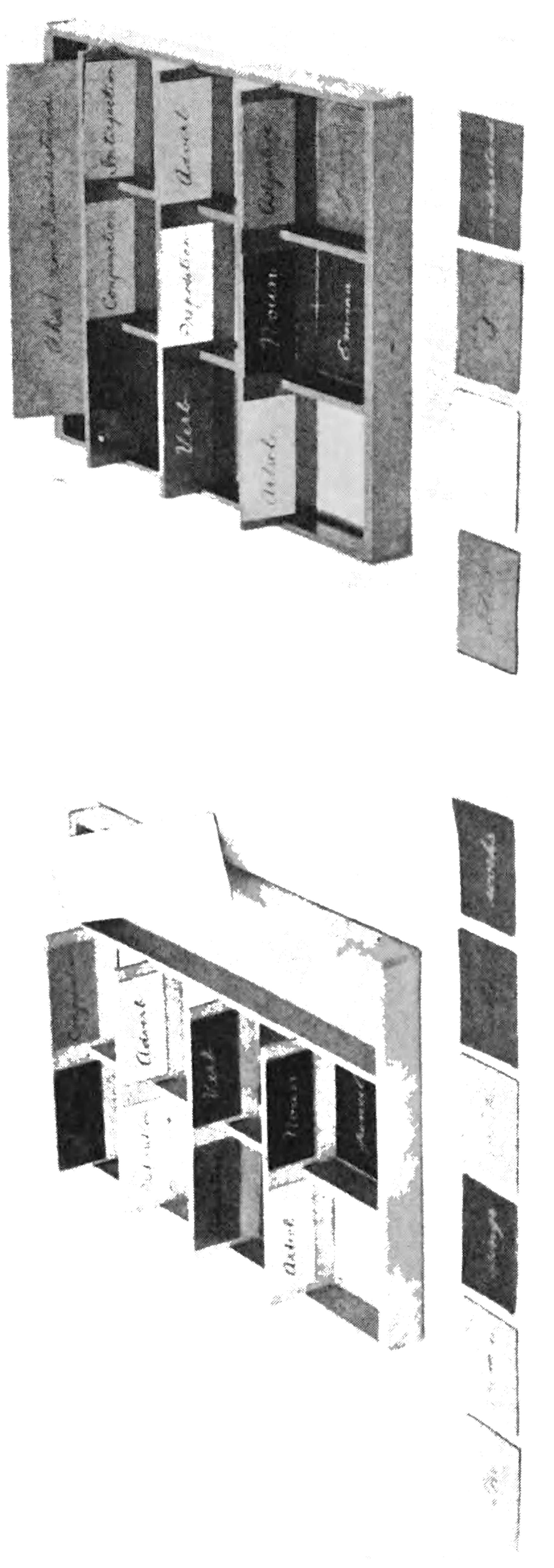

Grammar Boxes, showing respectively eight and nine parts of speech.

THIS PAGE IS LOCKED TO FREE MEMBERS

Purchase full membership to immediately unlock this page

Know Your Bible

Forgotten Books' Full Membership provides unlimited access to more than 28,000 volumes of Christian literature for \$8.99/month

HOLY BIBLE

Continue

*Fair use policy applies

PERMUTATIONS

The removal of the conjunction destroys the relationship between the words, and this brings out its function in the sentence:

Put away the pen and the ink-stand.

Put away the pen the ink-stand.

Put away the pen or the ink-stand.

Put away the pen the ink-stand.

You could write with your left hand if you touched the letters with that hand.

You could write with your left hand you touched the letters with that hand.

The conjunction must be placed between the words it connects: otherwise the meaning is changed or destroyed:

Put away the pen and the ink-stand.

Put and away the pen the ink-stand.

The "Children's House" is attractive because it is pretty.

The "Children's House" is attractive it is pretty.

LESSONS AND COMMANDS ON THE CONJUNCTIONS

Subject:

Coordinate conjunctions: and, or, neither, nor (e, o, nè).

Commands: —

— Come to "silence" where you are *and* move only at my call.

— Come to "silence" where you are *or else* move silently among the chairs.

— Walk on tip-toe about the room, being careful *neither* to meet *nor* to follow one another.

Subject: :

Declarative: that (che).

Command: —

— Tell two of your schoolmates *that* you know a conjunction.

Subject:

Adversatives: but, however, instead (ma, invece).

Command: —

— Form two lines; now one line face about turning from left to right; the other line, *instead*, turn in the opposite direction.

— Form in one long line and advance; when you reach the end of the room, do not stop, *but* turn to the left.

Subject:

Condition: if (se).

Command: —

— You will be able to hear this drop of water fall, *if* you remain for a moment in absolute silence.

Subject:

Time: while, when, as soon as (mentre, quando, appena).

Command: —

— A few of you walk about among the tables; then stop in the center of the room, *while* the others gather round you and try to cover your eyes with their hands.

— One of you start to leave the room. *When* you are about to cross the threshold, the others will block the way compelling you to stop.

— All of you ready! *As soon as* I say “Go!” run to the other end of the room.

Subject:

Purpose: so that, in order that (affinchè, perchè).

Command: —

— One of you stand in the middle of the room; the others try to pass near him quickly *so that* he cannot touch you.

— I am going to whisper a command: listen in perfect silence *in order that* you may hear what I command.

Subject:

Alternative: rather than (piuttostochè, anzichè).

Command: —:

— Those children who would *rather* work *than* go out of doors rise from their places.

Subject: :

Cause: because, since (perchè, poichè).

Command: —

— Before beginning to work let us become entirely quiet, *because* then we can think about what we are going to do.

Subject:

Exception: except, save (fuorchè, salvochè).

Command: —

— Get the counters and place one on every table in the room *except* on this one. Gather up all the counters *save* the red ones. Return all the counters to their box.

COMPARISON OF ADJECTIVES

SERIES A

— Of these two long rods, this one is the *longer*.

Of these three rods, which is the *longest*?

— This rod is *longer* than that.

That rod is the *longest* of the three.

Which is the *longest* of the series?

— This cloth is *smoother* than that.

This cloth is *smoothest* of all.

— Of these two shades of red which is the *darker*?

Of all these shades of red which is the *darkest*?

— Of these two prisms which is the *thicker*?

This prism is *thicker* than that.

Of these three prisms, which is the *thickest*?

— Which of these two children is the *taller*?

Which is the *tallest* child in the room?

THIS PAGE IS LOCKED TO FREE MEMBERS

Purchase full membership to immediately unlock this page



HISTORY

Tens of thousands of important historical sources, many previously unobtainable, are now available for the first time with a Forgotten Books Full Membership.

Unlimited Access
\$8.99/month

Continue

*Fair usage policy applies

short	dark	light	rough
short <i>er</i>	dark <i>er</i>	light <i>er</i>	rough <i>er</i>
short <i>est</i>	dark <i>est</i>	light <i>est</i>	rough <i>est</i>
beautiful		amusing	interesting
<i>more</i> beautiful	<i>more</i>	amusing	<i>more</i> interesting
<i>most</i> beautiful	<i>most</i>	amusing	<i>most</i> interesting

A second exercise contains cards for each of the forms for these same words. There are three colors: brown, light brown and dark brown (superlative). There are in addition similar cards for the adjectives of irregular comparisons, and three title cards: *Positive*, *Comparative*, *Superlative*. The exercise results as follows:

<i>Positive</i>	<i>Comparative</i>	<i>Superlative</i>
long	longer	longest
tall	taller	tallest
thick	thicker	thickest
smooth	smoother	smoothest
short	shorter	shortest
dark	darker	darkest
light	lighter	lightest
rough	rougher	roughest
beautiful	more beautiful	most beautiful
amusing	more amusing	most amusing
interesting	more interesting	most interesting
old	elder	eldest
many	more	most
good	better	best
bad	worse	worst
little	less	least

XI

INTERJECTIONS

Since this is the last part of speech to be studied the children are now able to recognize *all* the different parts of speech and it is no longer necessary to make sentences containing only parts of speech which the children know. Therefore in our Italian lessons we choose henceforth sentences from the classic authors (mostly from Manzoni). Since the interjection is really a thought expressed in an abbreviated form it lends itself readily to dramatic interpretation. With the same sentence the children accordingly can now perform the two-fold exercise of general analysis and "interpretative reading." They now recite sentences which they have picked out and studied instead of the commands. At this time also they are given a chart containing the complete classification of interjections. The children read them, interpreting each as they go along by voice and gesture. This is the first table of classification to be presented. Later on all the parts of speech will be given on charts with their definitions and classification.

ANALYSES

Material: The grammar box is complete. It now has nine separate compartments for the colored cards, article (tan), noun (black), adjective (brown), verb (red), preposition (violet), adverb (pink), pronoun (green), conjunction (yellow), and *interjection* (*blue*). In the com-

partment for the sentence slips are groups of cards which correspond exactly to the number of the words contained in the sentences.

GROUP A

(Per amor del cielo! oibò! addio! ehm! misericordia! ah!)

Please! Don't make so much noise!

Shame on you! exclaimed Henry, much shocked at those words.

Good-by! We shall see you to-morrow.

Look out! If you drop that vase, you will break it.

Mercy on us! What is the matter with the poor man?

Aha! now I understand!

GROUP B

(Eh via! bravo! bene! ehi! poh! per carità! oh!)

Come, come! Do you think I am going to believe all that nonsense?

Goodness! I hope the child is not going to fall.

Thanks! It was kind of you to help me put my objects away.

Cockadoodledoo! sang the rooster in the yard!

Ding-dong, ding-dong! The engines were passing by. There was a fire!

Cheer up! There is no harm done!

GROUP C

(Ohè! ih! toh! poveretto! ahi! ohi! eh! animo! uh! ton!)

Farewell! The ship gradually drew away from the shore! The houses faded from view one by one. The hills formed a low line on the horizon. *Farewell!* It would be months, years perhaps, before George would see the old familiar town again. *Farewell!*

Help! Help! came a voice through the fog! A man was drowning.

Hush! Do you hear that bird singing in the distance?

Alas! It was too late! When the doctor came, the poor man was dead!

THIS PAGE IS LOCKED TO FREE MEMBERS

Purchase full membership to immediately unlock this page

Know Your Bible

Forgotten Books' Full Membership provides unlimited access to more than 28,000 volumes of Christian literature for \$8.99/month

HOLY BIBLE

Continue

*Fair use policy applies

Hesitation: hum!

Resolution: by Jove!

Silence: hush! hist! listen! shh!

To animals: whoa! gee! haw! geddap! kitty-kitty! puss-puss!

Onomatapoetic: ding-dong! bang! whiz! bing! crack! snap!
etc., etc.

(In general the use of interjections, especially of capricious character, is much more characteristic of the best Italian writing and speech than it is of English.)

XII

SENTENCE ANALYSIS

I

SIMPLE SENTENCES

The material for logical analysis consists of little rolls of fairly stiff paper, on which are printed simple, compound and complex sentences, in carefully prepared series.

There is also a chart, divided into two columns of rectangular spaces, with the name of one sentence element printed in each space. The sentence read on the roll can be torn off part by part, and each of these parts is placed in one of the rectangles, according to the name printed on it. This is another application of the compartment box method used to analyze first the alphabet, then the sounds which go to make up the word, finally the words as parts of speech. Here, the compartments are reduced to a simple design.

The charts for logical analysis are on colored paper and are artistically drawn and decorated. We have charts of four different kinds as regards ornament and color, for such details exert a considerable influence upon the work of the children. On the following page is a sample of the charts with its "sections."

The two spaces at the top, subject and predicate, are somewhat larger and are more conspicuously decorated than the other rectangles below. The words *subject* and *verb* are printed entirely in large capitals. The other

CHART A

<p>VERB</p> <p>(The verbal or nominal predicate.)</p>	<p>Who is it that? What is it that?</p> <p>SUBJECT</p>
<p>Who? What?</p> <p>(Direct object.)</p>	<p>To whom? To what?</p> <p>(Indirect object.)</p>
<p>By Whom? By What?</p> <p>(Agent.)</p>	<p>Of whom? Of what?</p> <p>(Possessive, material.)</p>
<p>When?</p> <p>(Time.)</p>	<p>Where?</p> <p>(Place.)</p>
<p>Whence?</p> <p>(Source.)</p>	<p>How?</p> <p>(Manner.)</p>
<p>Why?</p> <p>(Cause.)</p>	<p>What for?</p> <p>(Purpose.)</p>
<p>By means of whom? By means of what?</p> <p>(Instrument.)</p>	<p>With whom? With what?</p> <p>(Accompaniment.)</p>
<p>(Attributive (phrases).)</p>	<p>(Vocative.)</p>

THIS PAGE IS LOCKED TO FREE MEMBERS

Purchase full membership to immediately unlock this page



HISTORY

Tens of thousands of important historical sources, many previously unobtainable, are now available for the first time with a Forgotten Books Full Membership.

Unlimited Access
\$8.99/month

Continue

*Fair usage policy applies

Another sentence: on the roll the child finds written:

The glass is broken.

The teacher can briefly explain that the verb taken by itself, has no special meaning. *Is* means nothing! “*Is? Is what?*” Some attribute must be added: “*Is broken!*” Here we get a *nominal predicate*. When the verb contains some definite meaning in terms of action, for instance *reads*, we get a *verbal predicate*. The section of the roll containing *is broken* is torn off, accordingly, and placed in the space of the verb. But *what* is broken? *The glass!* The section containing the words *the glass* is placed in the space of the subject. All of this can be copied off by the child by hand, as follows:

Simple sentence: The child reads.

The child: Subject.

Reads: Predicate (verbal).

SERIES I

(Simple Sentences)

The first roll contains the following simple sentences without modifiers of any kind:

- The child reads.
- The glass is broken.
- Charles is tall.
- The trees are blossoming.
- The blackboard is clean.
- Who has come?
- The pencil is broken.
- The sky is blue.
- I am reading.
- I am studying.
- The children are playing.
- Time flies.
- The teacher sings.

SERIES II

(Simple Sentences, containing a few modifiers)

The roll contains the following sentences, written one after another:

- The mother loves her child dearly.
- Johnny brought his teacher a rose.
- You may keep the book for some days, Louis.
- Mary, give the poor man a penny.
- Where have you been, Mary?
- I will do it, mother.
- Little Harry, only three years old, has cleaned the whole blackboard.
- Who drew the pretty picture?
- Last night I showed the letter to father.
- In the yard a red white and blue flag is waving.
- Did you go to the theater last night?
- The rain was beating against the window panes.
- The dog is barking at the cat.
- The poor deaf-mutes talk with their hands.

Example of application: The section containing the first sentence,

The mother loves her child dearly

is first torn off from the roll. Then the section containing the word *loves* is placed in the space marked *verb*. *Who loves? — the mother.* The section containing the words *the mother* is placed in the space marked *subject*. *The mother loved whom? Her child.* The section containing *her child* is torn off and placed in the space marked *direct object*. By thus reading the names printed in the spaces of the chart the child learns to classify the various kinds of modifiers. *How does the mother love her child? In what manner? Dearly.* The section containing the

word *dearly* is placed in the space marked *Manner* and the sentence is completed.

Now the child can copy off these analyses immediately or make others, as he thinks best. The copy may be as follows:

The mother loves her child dearly.

The mother: Subject.

Loves: Predicate (verbal).

Her child: Direct object.

Dearly: Adverb, manner.

In classifying the vocatives and attributives, a little help from the teacher may be required. Example:

You may keep the book for some days, Louis.

The word *Louis* can be dramatized somewhat into a kind of invocation, as — *O Louis, you may keep the book* and so on. Vocatives can almost always be identified by trying the exclamatory *O* before them.

In the sentence,

Little Harry, only three years old, has cleaned the whole blackboard.

only three years old is an attributive of Harry. It should be torn off and placed in the space marked *Attributive*.

SERIES III

(Simple sentences with two or more modifiers of the same kind)

The roll contains the following sentences in sections which may be read and torn off one after the other as the child unrolls the strip:

— The child sleeps and dreams.

— Everybody likes fruit and flowers.

THIS PAGE IS LOCKED TO FREE MEMBERS

Purchase full membership to immediately unlock this page

Know Your Bible

Forgotten Books' Full Membership provides unlimited access to more than 28,000 volumes of Christian literature for \$8.99/month

**HOLY
BIBLE**

Continue

*Fair use policy applies

- What nasty weather!
- What an attractive school!
- O for a calm, a thankful heart!
- A horse, a horse, my kingdom for a horse!
- Away with him!
- Fire! Fire!
- Here, here, quick!
- Honor to the brave!

SERIES VI

(Elliptical sentences where the direct object is understood:
incomplete predication)

- They drove away.
- He spends like a millionaire.
- He drinks like a fish.
- The farmer's boy had just milked.
- Do you understand?
- The cavalry spurred across the field at full speed.
- Did you see?
- The child did not hear.

SERIES VII

(Sentences with numerous modifiers and of increased
difficulty)

- The poor boy came home that night, all tired out, covered with mud from head to foot, with his coat torn and with a black and blue lump on his forehead.
- Ethel hurried home as fast as possible.
- We heard the clatter of horse's hoofs on the pavement.
- And so through the night went his cry of alarm
To every Middlesex village and farm.
- The beautiful child with the black hair is here on the lawn.

- And yet through the gloom and the night
The fate of a nation was riding that night.
- The woman walked along in front of me with the child in
her arms.
- The girl's voice sounded distinctly above all the others.
- To-morrow I shall come to town on foot.
- He spent the summer every year with his parents in their
old home on the mountain side.
- That evening the old house was more lonely than ever.
- They are very busy this morning.
- I never did such a thing in my life!
- Every now and then a group of people hurriedly crossed
the street.
- The doctor whispered something into the Mayor's ear.
- Just then some one knocked at the door.
- Here I am back again at my work.
- Mary had a little lamb
With fleece as white as snow.

THE ORDER OF ELEMENTS IN THE SENTENCE: PERMUTATIONS

Rules:

The English (the Italian) language tends to follow the direct order in prose, inversion being very rare.

In poetry, inversion is very common.

The direct order consists in placing: first, the subject, then the predicate, then the objects, direct and indirect; then the modifiers follow according to the importance they derive from the meaning of the sentence.

These ideas are after all so simple and clear that the child rarely has any difficulty in understanding them. Nevertheless, it is much easier to give the child a vivid impression of them by the permutation of parts than by

explanation. This permutation is made very convenient by the sentences being printed in sections which may be moved about and combined at will. Just as the sequence of the various parts of speech was made clear by transposing the parts, here the same result can be accomplished by transposing the sections of the printed slip. Example:

We	heard	the clatter	of the horse's hoofs
(subject)	(predicate)	(direct object)	(attribute)

on the pavement.
(place: adverb)

The following combinations are possible results of permutation:

We — heard — the clatter — of the horse's hoofs — on the pavement.

We — the clatter — heard — on the pavement — of the horse's hoofs.

We — of the horse's hoofs — on the pavement — the clatter — heard.

Of the horse's hoofs — on the pavement — heard — the clatter — we, etc., etc.

SERIES VIII

(The inverted order)

The effect of direct and inverted order can be shown in every sentence. But it is better to try examples of inversion from poetic language. In this series, all the sentences show inversion of one type or another:

— Meanwhile, impatient to mount and ride,
Booted and spurred, with a heavy stride
On the opposite shore walked Paul Revere.

— Upon the roof we sat that night!
The noise of bells went sweeping by;
Awesome bells they were to me.

— Still sits the school-house by the road.

THIS PAGE IS LOCKED TO FREE MEMBERS

Purchase full membership to immediately unlock this page



HISTORY

Tens of thousands of important historical sources, many previously unobtainable, are now available for the first time with a Forgotten Books Full Membership.

Unlimited Access
\$8.99/month

Continue

*Fair usage policy applies

ACTIVE VOICE (Action performed by subject)	PASSIVE VOICE (Action performed by agent)	REFLEXIVE (<i>Middle Voice</i>) (Subject is direct object)
The girl rocked her little friend to sleep in the rocking-chair.	The little friend was rocked to sleep in the rocking-chair by the little girl.	Her little friend rocked herself to sleep in the rocking-chair.
The teacher saw Henry in the large mirror.	Henry was seen in the large mirror by the teacher.	Henry saw himself in the large mirror.
The angry boy hurt Louis.	Louis was hurt by the angry boy.	Louis hurt himself.

SERIES X

(Use of the personal pronoun)

The sentences previously given for analysis in teaching the personal pronouns can be used over again at this point for analysis on the sentence-chart.

- The children wrote a letter to their mother
The children wrote her a letter
They wrote it to her
- They gave their mother a surprise
They gave her a surprise
- I told father all about it
I told him all about it
- Charles soothed his sister with a kiss
He soothed her with a kiss
- Will you give your drawing to the teacher?
Will you give her your drawing?
Will you give it to her?
- Don't think badly of your schoolmates
Don't think badly of them
- Show those dirty hands to the teacher
Show her those dirty hands
Show them to her
- Tell the story to the children in the other room
Tell it to the children in the other room
Tell it to them there

The exercise in permutation brings out the relative positions of the direct and indirect objects; as also the conditions under which the preposition *to* is required before the indirect object.

II

COMPOUND AND COMPLEX SENTENCES

Here we are dealing with a number of propositions (clauses) which combine into one complete meaning. The clauses fit together in the sentences just as did the various elements in the simple sentence. The material for the analysis is therefore analogous to that used in the analysis of the simple sentence: strips of paper in rolls on which are written the sentences to be analyzed, and a chart with spaces where the detached pieces may be placed, according to the designation of these spaces.

The principal space on the chart is reserved for the main clause, around which the other clauses are arranged, as coordinate or subordinate.

Since the work of logical analysis of the complex sentence is sufficiently interesting to attract the attention of the child to various forms of study, the material contains in addition to the rolls and the chart, a number of test-cards where the analysis is completed and logically demonstrated. These cards serve as tests of the accuracy of the work done by the children, and as actual charts for analytical study. Of course, when the child is doing his exercise with the strips of paper and the chart, he does not have these test-cards before him. He should, however, always have free access to them. His interest in the game is to succeed by himself in placing the different propositions where they belong.

CHART B

PRINCIPAL CLAUSE	
INCIDENTAL CLAUSES (Parenthetical clauses)	
SUBORDINATE ATTRIBUTIVE CLAUSE (Adjective or Relative clauses)	
<p>who is it that . . . ? subordinate <i>subject</i> clause (subject clause)</p>	<p>whom . . . ? what . . . ? subordinate <i>object</i> clause (object clause)</p>
<p>when . . . ? subordinate clause of <i>time</i> (temporal clause)</p>	<p>where . . . ? subordinate clause of <i>place</i> (locative clause)</p>
<p>for what purpose . . . ? subordinate clause of <i>purpose</i> (purpose clause)</p>	<p>why . . . ? for what cause ? subordinate clause of <i>cause</i> (causal clause)</p>
<p>how . . . ? than what ? subordinate clause of <i>manner</i> or <i>comparison</i> (modal clauses)</p>	<p>on what condition . . . ? subordinate clause of <i>condition</i> (conditional clause)</p>
<p>in spite of what . . . ? subordinate clause of <i>concession</i> (concessive clause)</p>	<p>with what result . . . ? subordinate clause of <i>result</i> (result clause)</p>

THIS PAGE IS LOCKED TO FREE MEMBERS

Purchase full membership to immediately unlock this page

Know Your Bible

Forgotten Books'
Full Membership
provides unlimited
access to more than
28,000 volumes of
Christian literature for
\$8.99/month

**HOLY
BIBLE**

Continue

*Fair use policy applies

Louis clapped his hands for joy.

 began to dance around the room.

He looked into the mirror.

 straightened his tie.

 smoothed his hair.

and went out to meet his two friends.

The bees hummed in the warm sunshine.

And the cat sat purring at her side.

Then he began to weep.

And he tore his hair in anguish.

The girl covered her face with her hands.

and wept.

They looked at the speaker.

 crowded around him.

and waited for his next word to attack him.

SERIES II

(The Complex Sentence)

Here only the main clause has a complete meaning. The other clauses make sense only when they are united with the main clause. On this roll, the subordinate clauses are attributes of one of the elements of the main clause (relative clauses).

— The gold ring which you found yesterday on the stairs belongs to mother.

— The man who brought me to school this morning was my uncle.

— He was educated by his sister who taught him many beautiful things.

— The colors which Aunt Anna gave me Christmas are very good.

— A little girl who was at a party sat looking with longing eyes at a plate of sandwiches.

— The knife with which you sharpened my pencil was very dull.

- Bees don't care about the snow!
 I can tell you why it's so:
 Once I caught a little bee
 Who was much too warm for me.—(F. D. SHERMAN)
- We have at home the prettiest cat you ever saw.
- Here are the pennies my mother gave me.
- The children I play with did not come to school to-day.
- The house we live in is beautiful and airy.
- Stars are the little daisies white
 That dot the meadow of the night.—(SHERMAN)

TEST CARDS

PRINCIPAL CLAUSE
 (The words modified by the relative
 clause are in *italics*).

ATTRIBUTIVE SUBORDINATE CLAUSE
 (Relative or Adjective Clauses)
 (The clause has no meaning until
 united with some noun in the
 main clause).

The gold *ring* belongs to
 mother

which you found on the stairs
 yesterday

The *man* was my uncle

who brought me to school this
 morning

He was educated by his *sister*

who taught him many beauti-
 ful things

The *colors* are very good

which Aunt Anna gave me
 Christmas

A little *girl* sat looking with
 longing eyes at a plate of
 sandwiches

who was at a party

Once I caught a little *bee*

who was much too warm for
 me

Stars are the little *daisies*
 white

that dot the meadow of the
 night

RELATIVE OMITTED

What word is omitted?

Here are the *pennies*

—my mother gave me

The *children* did not come to
 school to-day

with — I play

The *house* is beautiful and
 airy

in — we live

SERIES III

In the preceding roll, the subordinate clauses completed the meaning and constituted an attribute of *one word* of the principal clause. Here, however, the subordinate clauses refer to the whole content of the main clause and complete *the whole thought* of the main clause. They have, therefore, a logical dependence on the main clause. The child will be guided in finding the place of the different subordinate clauses and in classifying them according to the designations of the spaces by the questions which appear in the analytical chart. It is presupposed that he can readily identify the main clause itself.

The following sentences come one after the other on the rolled strip of paper:

- Do not forget that your objects are not in their places.
- Will you play with me when you have finished your work?
- When the sun is low our shadows are longer.
- I hope that you will write me a long letter as soon as you arrive in Europe.
- The little girl stood on tiptoe so that she could see the queen as the procession went by.
- Brer Rabbit thought it was the worst time he had had in all his life.
- All is well that ends well, says the proverb.
- The people mourned when the good President died.
- It is not right that the big boys should have all the candy.
- As she sat there reading, a beautiful red bird flew in through the window.
- They could not play in the yard because the ground was too wet.
- Remember that you must thank the lady who gave you the book.

THIS PAGE IS LOCKED TO FREE MEMBERS

Purchase full membership to immediately unlock this page



HISTORY

Tens of thousands of important historical sources, many previously unobtainable, are now available for the first time with a Forgotten Books Full Membership.

Unlimited Access
\$8.99/month

Continue

*Fair usage policy applies

- When the wolf came out, Brer Rabbit threw the stone on him and laughed.
- When the lady knocked on the door, a smiling old man appeared and asked what he might do for her.
- The children walked along in the forest and became very hungry because they had had nothing to eat since morning.
- The king's face grew very red and he angrily ordered that the deceitful general be put to death.
- Since the wind was blowing hard, the captain told the children to keep off the deck and a sailor carried them to their state-rooms.
- The dogs began to bark and the people all ran out into the streets as the uproar of the combat increased.
- Where that tree now stands, there was once a beautiful house and a fine road led up to it.
- He had left the village and mounted the steep,
And under the alders that skirt its edge,
Now soft on the sand, now loud on the ledge,
Is heard the tramp of his steed as he rides.

TEST CARD

PRINCIPAL CLAUSE	COORDINATE CLAUSE	QUESTION	SUBORDINATE AND ATTRIBUTIVE CLAUSES
He rose from his chair	and left the room	when?	as he said this
The two friends shook hands	and said	what?	that they would always be faithful to each other
Brer Rabbit threw the stone on him	and laughed	when?	when the wolf came out
A smiling old man appeared	and asked	what?	what he might do for her
		when?	when the lady knocked on the door
The children walked along in the forest	and became very hungry	why?	because they had had nothing to eat since morning
The king's face grew very red	and he angrily ordered	what?	that the deceitful general be put to death
The captain told the children to keep off the deck	and a sailor carried them to their state-rooms	why?	because the wind was blowing hard
The dogs began to bark	and the people all ran into the streets	when?	as the uproar of the combat increased
There was once a beautiful house	and a fine road led up to it	where?	where that tree now stands

PRINCIPAL CLAUSE	COORDINATE CLAUSE	QUESTION	SUBORDINATE AND ATTRIBUTIVE CLAUSES
He had left the village	and mounted the steep under the <i>alders</i> now soft on the sand, now loud on the ledge, is heard the tramp of his steed	when?	that skirt its edge (attributive). as he rides

SERIES V

(Correlative Sentences)

The clauses are here dependent upon each other:

- The flowers were so beautiful that we picked them all.
- That day he was so lazy that he did not get his work done.
- She sings much better than she plays.
- The more one studies, the more one learns.
- Either you return your objects to their places or some one else must do it.
- Not only was the man very cross, but he actually punished the little boy.

TEST CARD

PRINCIPAL CLAUSE	QUESTION	SUBORDINATE CLAUSE
The flowers were so beautiful	with what result?	that we picked them all.
That day he was so lazy	with what result?	that he did not get his work done.
She sings much better	than what?	than she plays.
The more one studies	with what result?	the more one learns.
Either you return your objects to their places	with what result?	or some one else must do it.
Not only was the man very cross	with what result?	but he actually punished the little boy.

SERIES VI

(The Order of Clauses in Sentences:
Sentence Forms in Prose and Verse)

Our material makes it very easy for the children to understand the mutual dependence of the subordinate

clauses. We take the commonest cases within easy reach of the children. There are clauses of the first degree of subordination, dependent directly on the principal clause. There are others of the second degree of subordination which depend on a subordinate clause (clause subordinate to a subordinate). We have the same situation in coordinates. We have the first degree of coordination when the clause is parallel with the principal clause, and the second degree when the clause is parallel with a subordinate clause.

Since the slips have as many sections as there are clauses, the clauses may be arranged on the table in the order of their subordination, keeping, for example, the principal clause to the left, and arranging the subordinate clauses downward and downward to the right. Take, for instance, the sentence:

— The old man liked to tell stories; and he would laugh heartily when the women were frightened at the terrible things that he had to relate.

As the different clauses are torn off they are placed on a chart marked into sections by vertically placed arrows: the principal clause to the right of the first arrow; the first subordinate clause to the right of the second; the subordinate to the subordinate to the right of the third, and so on. The above sentence results as follows:

Principal and Coordinate	1st subordinate	subordinate to subordinate
The old man liked to tell stories and he would laugh heartily	when the women were frightened at the terrible things	that he had to tell.

THIS PAGE IS LOCKED TO FREE MEMBERS

Purchase full membership to immediately unlock this page

Know Your Bible

Forgotten Books' Full Membership provides unlimited access to more than 28,000 volumes of Christian literature for \$8.99/month

HOLY BIBLE

Continue

*Fair use policy applies

him the classification of the clauses. The strips are then to be placed on the dependence chart (Chart C) according to the indications of the arrows. This brings out the mutual relation of the clauses.

PERMUTATIONS

The preceding exercises have created in the child a notion of sentence construction and of the position of the clauses which make it up. Our material permits, of course, as an exercise supplementary to the analyses, dislocations and translocations of parts just as was true with the simple sentence. To derive the full benefit of this possibility, the teacher should have in mind the general rules for location of clauses:

Adjective clauses (relative, attributive) always follow, and most often directly, the noun they modify.

Subject subordinate clauses may stand either before or after the principal clause. If the subject clause follows, it is usually anticipated before the verb by the pronoun *it* (just as a following noun subject is anticipated by *there*).

(In Italian, if the object clause precedes the main clause, it is usually repeated before the noun by a conjunctive object personal pronoun.)

The position of the other clauses depends on considerations of emphasis.

The direct order for complex sentences is in general similar to that for simple sentences:

subject clause
principal clause
object clause
adverbial clauses.

Coordination is possible with subordinate as well as with principal clauses.

The special exercises on the complex sentence conclude with some practise in turning simple inversions as found in poetry into direct sentence order.

SERIES VII

The detachable strips are used here also. The exercise should be conducted with reference to the sentence charts.

1

— Just where the tide of battle
turns,
Erect and lonely stood old
John Burns . . .
And buttoned over his manly
breast
Was a bright blue coat with a
rolling collar.

Old John Burns stood, erect and
lonely just where the tide of
battle turns. . . .
A bright blue coat, with a rolling
collar, was buttoned over his
manly breast.

2

— It was terrible: on the right
Raged for hours the deadly
fight,
Thundered the battery's dou-
ble bass,
Difficult music for men to face;
While on the left, where now
the graves
Undulate like the living waves
That all that day unceasing
swept
Up to the pits the rebels kept,
Round shot ploughed the up-
land glades.

It was terrible: the deadly
fight raged for hours on the
right; the battery's double bass
thundered,—difficult music for
men to face; while round shot
ploughed the upland glades on
the left, where now the graves
undulate like the living waves
that swept unceasing all that day
up to the pits the rebels kept.

BRET HARTE.—*John Burns
of Gettysburg.*

3

— Merrily rang the bridle reins,
and scarf and plume
streamed gay,
As fast beside her father's
gate the riders held their
way . . .

The bridle reins rang merrily
and scarf and plume streamed
gay, as the riders, held their way
fast by her father's gate.

“Now break your shield asunder
 and shatter your sign
 and boss,
 Unmeet for peasant-wedded
 warms, your knightly
 knee across.

WHITTIER.—*King Volmer.*

4

The breaking waves dashed high
 On a stern and rock-bound coast;
 And the woods against a stormy
 sky
 Their giant branches tossed.
 And the heavy night hung dark
 The hills and waters o'er,
 When a band of Pilgrims moored
 their bark
 On the wild New England shore.

Not as the conqueror comes
 They the true hearted came,
 Not with the roll of the stirring
 drums
 And the trumpet that sings of
 fame.

MRS. HEMANS.

5

My golden spurs now bring to me
 And bring to me my richest mail,
 For tomorrow I go over land and
 sea
 In search of the Holy Grail.
 Shall never a bed for me be
 spread,
 Nor shall a pillow be under my
 head,
 Till I begin my vow to keep;
 Here on the rushes will I sleep,
 And perchance there may come a
 vision true
 Ere day create the world anew.

LOWELL.

Now break your shield asunder
 and shatter across your knightly
 knee your sign and boss unmeet
 for peasant-wedded arms.

The breaking waves dashed
 high on a stern and rock-bound
 coast; and the woods tossed their
 giant branches against a stormy
 sky.

The heavy night hung dark
over (o'er) the hills and waters,
 when a band of Pilgrims moored
 their bark on the wild New Eng-
 land shore.

They, the true hearted, came
 not as the conqueror comes, not
 with the roll of the stirring
 drums and the trumpet that
 sings of fame.

Bring to me now my golden
 spurs and bring to me my richest
 mail; for I go in search of the
 Holy Grail tomorrow over land
 and sea; a bed shall never be
 spread for me, nor shall a pillow
 be under my head till I begin to
 keep my vow; I will sleep here
 on the rushes, and perchance a
 true vision will come *before (ere)*
 day creates the world anew.

THIS PAGE IS LOCKED TO FREE MEMBERS

Purchase full membership to immediately unlock this page



HISTORY

Tens of thousands of important historical sources, many previously unobtainable, are now available for the first time with a Forgotten Books Full Membership.

Unlimited Access
\$8.99/month

Continue

*Fair usage policy applies

8

Childhood is the bough where
 slumbered
 Birds and blossoms many num-
 bered;
 Age that bough with snows en-
 cumbered.

LONGFELLOW.

Childhood is the bough where
 many numbered birds and blos-
 soms slumbered: Age encum-
 bered that bough with snow.

TEST CARDS

1

Just where the tide of battle
 turns
 Erect and lonely stood old John
 Burns
 And, buttoned over his manly
 breast,
 Was a bright blue coat with a
 rolling collar

subordinate of place (locative)

principal

(verbal attributive phrase)

coordinate of principal.

2

It was terrible
 on the right
 raged for hours the deadly fight
 thundered the battery's double
 bass
 Difficult music for men to face
 While on the left (round shot
 ploughed, etc.)
 where now
 the graves
 Undulate like the living waves
 That all that day unceasing
 swept
 up to the pits
 the rebels kept
 Round shot ploughed the upland
 glades

principal

coordinate of principal

coordinate of principal

(verbal attributive phrase in ap-
 position).

subordinate of time (temporal)
 begun

(*While* may be considered as ad-
 versative coordinate)

subordinate to subordinate (lo-
 cative) 2d degree

attributive subordinate (relative
 adjectival clause modifying
waves) of 3d degree

attributive subordinate (relative
 pronoun omitted) of 4th de-
 gree

subordinate of time (concluded).

152 MONTESSORI ELEMENTARY MATERIAL

3

Merrily rang the bridle reins	principal
and scarf and plume streamed gay	coordinate
As fast beside her father's gate the riders held their way	subordinate of time
Now break your shield asunder	principal
and shatter your sign and boss	coordinate
Unmeet for peasant-wedded arms your knightly knee across	

4

The breaking waves dashed high On a stern and rock-bound coast	principal
And the woods against a stormy sky Their giant branches tossed.	coordinate
And the heavy night hung dark The hills and waters o'er	principal (coordinated in paragraph)
When a band of pilgrims moored their bark On a wild New England shore	subordinate temporal
Not as the conqueror comes They the true hearted came Not with the roll of the stirring drums and the trumpet	principal begun subordinate of manner (modal) principal concluded
that sings of fame	coordinate (elipsis of verb <i>they came</i> continued from principal) attributive (relative) subordinate to coordinate.

5

My golden spurs now bring to me	principal
And bring to me my richest mail	coordinate

For tomorrow I go over land and sea In search of the Holy Grail	subordinate of cause (causal); may be considered <i>coordinate</i> of <i>reason</i>
Shall never a bed for me be spread	principal
Nor shall a pillow be under my head	coordinate
Till I begin my vow to keep	subordinate of time (temporal)
Here on the rushes will I sleep	principal
And perchance there may come a vision true	coordinate
Ere day create the world anew	subordinate temporal.

6

Great tidings of great joy I bring To you and all mankind	principal
To you in David's town this day Is born of David's line The Saviour	principal
who is Christ the Lord	attributive (relative) subordi- nate
And this shall be the sign	coordinate
The heavenly Babe you there shall find To human view displayed All meanly wrapt in swaddling bands And in a manger laid.	simple sentence with three co- ordinate verbal phrases.

7

The harp that once through Tara's hall	principal begun
The soul of music shed	attributive subordinate (rela- tive)

THIS PAGE IS LOCKED TO FREE MEMBERS

Purchase full membership to immediately unlock this page

Know Your Bible

Forgotten Books'
Full Membership
provides unlimited
access to more than
28,000 volumes of
Christian literature for
\$8.99/month

**HOLY
BIBLE**

Continue

*Fair use policy applies

(Note: the best English poetry makes far less use of inversion than does Italian. Such exercises as the above could be profitably applied to the analysis of the different kinds of phrases (adjective, adverbial, etc.). It should be noted that Dr. Montessori in her own exercises treats verbal phrases (participles and infinitives) as subordinate clauses.—TR.)

COORDINATING AND SUBORDINATING CONJUNCTIONS

This study of the complex sentence leads the child to a more precise comprehension of the values of certain parts of speech as, notably, the conjunction. We have found, in fact, that little difficulty is experienced in realizing the distinction between the terms *coordinating* and *subordinating* as applied to conjunctions which *unite* clauses but in different ways. The following charts serve to cover the vast majority of cases that the child is likely to meet. We may add that at this point it may be found useful to have the child analyze the complex sentences which appeared in the commands and readings already familiar to him (see below under *Reading*).

COORDINATING CONJUNCTIONS

Copulatives: and, also, too, besides, moreover, further, furthermore, nor.

Disjunctives: or else, otherwise, rather.

Adversatives: but, nevertheless, however, notwithstanding, yet, still, while, only, instead.

Declaratives: namely, in other words, that is.

Asseverative: in fact, assuredly, really.

Illative: hence, therefore, then, accordingly, so.

PRINCIPAL AND COORDINATE CLAUSES MAY BEGIN WITH
ONE OF THESE CONJUNCTIONS

CHART D

THE CONJUNCTIONS IN THE SUBORDINATE
CLAUSE

PRINCIPAL CLAUSE	
Incidental (parenthetical) clause	
Adjective (relative, attributive) clause who, which, that, whose, whom	
Subordinate subject clause that	Subordinate object clause that
Subordinate clause of time (temporal) when, while, as soon as, before, after, till, until	Subordinate clause of place (locative) where, whence, wherever, whither
Subordinate clause of purpose (final, purpose clause) that, in order that, so that	Subordinate clause of cause (casual clause) as, because, for, since, in as much as
Subordinate clause of manner and comparison (modal clause) as (manner), than (com- parison)	Subordinate clause of condition (conditional clause) if, unless, provided, pro- vided that
Subordinate clause of concession (concessive clause) though, although, even if, however, notwithstand- ing that	Subordinate clause of result and correlatives that, so that (result) so . . . as, so . . . that (correlative, degree)

SEQUENCE OF TENSES

A special series of exercises on the relations of the subordinate to the principal clause brings out the changes in tense made necessary in the subordinate clause as the tense of the principal clause varies.

SERIES VIII

Sequence of Tenses

GROUP A

(Causal Clauses)

- I am writing to you because I have some important news.
 " wrote " " " " had " " "
- I shall not go because I must attend to my work.
 " did " " " " had to " " "
- I am glad that you have done so well.
 " was " " " had " " "
- I will give it to you since you insist on having it.
 " gave " " " " " insisted " " "
- He does not answer because your letter is insulting.
 " did " " " " " was "

GROUP B

(Miscellaneous Clauses)

- I shall be proud of you if you become a fine scholar.
 " should " " " " " " became " " "
- I believe that only the rich can be happy.
 " believed " " " " could " "
- I am waiting here till my father returns from town.
 " waited " " " " returned " "
- They expect that something will happen before long.
 " expected " " would " " "

THIS PAGE IS LOCKED TO FREE MEMBERS

Purchase full membership to immediately unlock this page



HISTORY

Tens of thousands of important historical sources, many previously unobtainable, are now available for the first time with a Forgotten Books Full Membership.

Unlimited Access
\$8.99/month

Continue

*Fair usage policy applies

— He would give it to you if you should ask him for it.

— I shall go there if I have time.

” should ” ” ” ” had ”

” shall ” ” ” ” should have ”

” should have gone ” ” ” had had ”

XIII

PUNCTUATION

The permutations of clauses permitted by our materials give empirical evidence of the pauses and accordingly of the functions of the orthographical signs of suspense in the sentence. These signs are included also in our alphabets. All the exercises hitherto given require more or less spontaneous attention to punctuation. We offer, however, in addition, several series of sentences for analysis in illustration of the principal rules for the use of punctuation points. Almost all of our Italian sentences are taken from Manzoni, a writer especially noteworthy for his care in punctuation. (The majority of the sentences below are taken from the *Book of Knowledge*, by special permission of the publishers.)

SERIES I

The comma may separate coordinate elements.

- The mother took a glowing pride in the beauty of her children's faces, the grace and strength of their bodies, their reckless daring and unflinching courage.
- The little star fell plump into the middle of a big puddle, and there it lay sad and shaken and quaking with fright.
- It was dumb and half blind, it had a soiled face, and could give no more light.
- A mouse was just then peeping from its hole to see whether it was going to rain, and whether it would be safe to cross the fields.
- The mouse started running again, and ran until it was tired out and had to sit down.

- The little star poured a flood of bright light over the poor woman, and made her bright and cheerful and strong again, and then the little girl became very happy.

SERIES II

A comma isolates vocatives and incidental clauses.

- “Cæsar, let your men go forward,” said the guide.
 —Why do you want to find your father, Mora?
 —“No,” said he, “I shall be very well presently.”
 —“Boys,” said our host, “I know whose hand it is.”
 —That, excuse me for saying so, is not the way to speak to a friend.
 —“Come with us, you handsome young huntsman,” he cried.

SERIES III

A comma separates clauses, especially for clearness, when the elements of one clause might seem to apply equally well to another clause, and when one clause is interpolated between the essential elements of another.

- Mohammed taught that men should pray at stated times, wherever they are.
 —George, who was only five years old, could not go with his father to fight.
 —The tribemen, after quarreling a long time, decided to march away.
 —He went that evening, as he had planned, to the doctor’s house.
 —The poor Indian had been kept moving, ever since he was born, to regions farther and farther north.
 —The child crept to the bed, and, taking his little fan, stood over his father all night fanning him.

SERIES IV

A comma indicates a pause caused by the ellipsis of some word or idea (in such cases longer suspense can be indicated by a colon or a semi-colon).

THIS PAGE IS LOCKED TO FREE MEMBERS

Purchase full membership to immediately unlock this page

Know Your Bible

Forgotten Books'
Full Membership
provides unlimited
access to more than
28,000 volumes of
Christian literature for
\$8.99/month

**HOLY
BIBLE**

Continue

*Fair use policy applies

— When he got home, he said to his wife: “ See, I have brought you a present.”

— He shouted gleefully: “ I am a lion — a terrible lion.”

SERIES VI

(Other Punctuation Points)

The period, question mark, exclamation point and other signs of punctuation:

In this series should be given dialogues, interesting stories, passages which express emotional states of mind vividly portrayed. Such selections, as is true also of our shorter passages, ought to be taken from the best writers, distinguished by the naturalness and vivacity of their style and the use of an accurate orthographical technique. At this point we make use of the selections used for our “ interpretations,” since the question of punctuation coincides with the problems of text interpretation itself.

XIV

WORD CLASSIFICATION

THE KINDS OF WORDS

In doing the work outlined thus far, the children have acquired considerable resources in vocabulary. They have seen all the articles, prepositions, pronouns, conjunctions, interjections, many of the adverbs; and they know many nouns, adjectives, and verbs, which will be increased in number as their culture is widened. They know something also of the use of the parts of speech and their functions in the expression of thought. This is the natural place for a classification in retrospect of those words which the children have in writing before them on the cards and slips of different colors. Separate tables should be used for these exercises in word grouping.

This new step is preparatory to a *theoretical study* of language to be developed in later courses in the second period of their education.

WORDS CLASSIFIED ACCORDING TO FORMATION

Root	}	words
Derived ¹		
Compound ²		

¹ Under this heading we include all derivations by suffix: some suffixes change one part of speech into another: *love* (verb), *lovable* (adj.), etc.; others, such as *diminutives*, *peggioratives*, *augmentatives*, etc., change the quality of a word's meaning. In adjectives we have suffixes of degree (comparison: *-er*, *-est*).

² Under this heading we include all words formed by the union of two words or by prefixes.

CLASSIFICATION OF WORDS ACCORDING TO INFLECTION

There are two kinds of words, thus considered: variable and invariable:

INVARIABLES:	{ preposition conjunction interjection	{ They may be simple or compound, made up, that is, of one word or more.	
VARIABLES:	{ in gender and number }	nouns	{ may be of masculine, feminine, neuter or common gender. form their plurals by adding -s or by changing the root vowel (umlaut)
	{ in gender, number, person and case }	pronouns	{ have special words for each form: e.g. he, him, who, whom, I, me, etc.
	{ in degree }	{ adjectives adverbs }	{ -er for comparative -est for superlative
	{ in person, number, tense and mood }	Verbs	{ show third person sin- gular by adding -s, and old second per- son singular by add- ing -st show moods by adding -ing, -ed or by vowel change for partici- ples, or by special forms (I be, he be, etc.) for subjunctive. show tense by suffix -ed, -t; or by vowel change (I go, I went). show irregular forms.
	{ for phonetic reasons }	{ definite article indefinite }	{ the has two pronounci- ations according to the following word. a becomes an before a vowel.

CLASSIFICATION OF WORDS ACCORDING TO THEIR USE

(Parts of Speech)

Article	Verb	Pronoun
Noun	Adverb	Conjunction
Adjective	Preposition	Interjection

NOTE: In actual usage the parts of speech perform not only their own functions, but also the functions of other

THIS PAGE IS LOCKED TO FREE MEMBERS

Purchase full membership to immediately unlock this page



HISTORY

Tens of thousands of important historical sources, many previously unobtainable, are now available for the first time with a Forgotten Books Full Membership.

Unlimited Access
\$8.99/month

Continue

*Fair usage policy applies

Note: Certain verbs may be by nature both transitive and intransitive (incomplete predication).

Impersonals (the subject is *it* without reference to a specific object):

{	rain, snow, hail, dawn, lighten, thunder, etc.
---	--

ADVERBS

of Manner:	{	slowly, rapidly, silently, noisily, abruptly, loudly, strongly, weakly, moderately, well, ill, better, worse, otherwise, differently, thus, so, lightly, heavily, etc., etc.
of Place:	{	here, there, elsewhere, up, down, forward, backward, upstairs, downstairs, etc., etc.
of Time:	{	always, ever, never, again, still, yesterday, tomorrow, today, now, occasionally, before, afterwards, soon, etc., etc.
of Quantity:	{	much, little, enough, nothing, more, less, least, most, about, only, too, very, etc.
of Comparison:		more, less, than, etc.
of Affirmation:	{	yes, certainly, precisely, indeed, surely, assuredly, truly, even, etc.
of Negation:		no, never, not, at all, etc.
of Doubt:		perhaps, perchance, almost, probably, etc.

PREPOSITION

Simple:	{	of, to, by, from, in, with, on, among, above, through, under, around, beside, behind, save, except, near, next, like, during, off, etc.
Compound (preposition phrases):		in place of, out of, away from, as to, on board, with regard to, etc.

PRONOUN

Personal	{	subject: { I, thou, he, she, it, we, you, they
	{	object: { me, thee, him, her, it, us, you, them
Demonstrative	{	definite: { this, this one, that, that one, these, those
	{	indefinite: { one, ones, some, somebody, everyone, each, each one, no one, nobody, none, nothing, etc.

Relative { of person: { subject: who, that
 { possessive: whose
 { object: whom, that
 of thing: which, that
 indefinite: whoever, which ever
 compound (antecedent understood): what (that
 which), whereof, wherewith, etc.

Interrogative: { of person { who
 { whose
 { whom
 { which
 of thing { what
 { which

Possessive: mine, yours (thine), his, hers, ours, yours, theirs.

CONJUNCTION

Disjunctive: or, or else, otherwise, rather.

Copulative: { and, also, too, besides, moreover, further, further-
 more, nor, etc.

Adversative: { but, nevertheless, notwithstanding, yet, still, while,
 however, only, on the contrary, instead, etc.

Declarative: namely, in other words, that is, etc.

Relative: that.

Illative: { hence, therefore, wherefore, then, accordingly, so, with
 the result that, etc.

Temporal { while, when, as soon as, after, before, until, till,
 hardly, etc.

Concessive: though, although, even if.

Purpose (Final): that, in order that, to the end that, etc.

Conditional: if, unless, provided, provided that, etc.

Causal: as, because, for, since, seeing that, etc.

Result: that, so that, etc.

Locative: where, whence, whither, whereto, wherefrom, etc.

Degree and Comparison: as, than.

INTERJECTION

See list already given on pp. 122-123.

PART II
READING

THIS PAGE IS LOCKED TO FREE MEMBERS

Purchase full membership to immediately unlock this page

Know Your Bible

Forgotten Books' Full Membership provides unlimited access to more than 28,000 volumes of Christian literature for \$8.99/month

**HOLY
BIBLE**

Continue

*Fair use policy applies

EXPRESSION AND INTERPRETATION

MECHANICAL PROCESSES

Reading begins in the "Children's House" as soon as the children *reread* the word they have already composed with the movable alphabet. This early effort is not indeed the true reading of the word, since interpretation is lacking. The children, it has been seen, know the word because they have actually put it together. They have not gained an understanding of it from the simple recognition of the graphic symbols. What they have done is, nevertheless, an important contribution to real reading. As one considers all of the details of this period of development, it is apparent that its mechanism is closely allied with that of the spoken language.

When the child's attention has been intensively applied to the recognition of the written word, it can easily be fixed on the analysis of the sounds which make up the word. At a certain age the child's interest was aroused by "touching" the letter. He can now be interested in hearing the sounds of the word when pronounced by others and in pronouncing it himself. We have shown that the work on the written language in the exercises with the alphabet was *necessary* for developing and perfecting the spoken language. It is by so doing that we make it possible to correct defects in speech and to pass naturally over the period when such defects are formed.

We now aim at finding an *exercise* in the actual mechanism of pronunciation which can be started at the moment of its natural development in such a way that its growth to perfection will follow as a matter of course. It is a question of bringing the children rapidly to pronounce without hesitation. In so pronouncing well, in performing extensive exercises in hearing words and in the interpretation of them from graphic signs, the child brings together in a unit of effect the basic processes of reading and writing.

A good pronunciation of the word read is of great importance. We may say that in the elementary schools of our day this is the principal purpose of reading. Nevertheless, it is very difficult to obtain a good pronunciation when defects have been allowed to develop and become habitual in the child's previous work. In fact, the elimination of these defects, which have been the result of a fundamental error in education, comes to absorb all of the energies of the reading class in ordinary primary schools. So far along as the fifth grade we see teachers struggling to make the children read, that they may acquire a good "pronunciation," and in our reading books there are graduated exercises constructed on the basis of "Difficulties in Pronunciation." It is apparent that all of this stress on the *physiological mechanics* of pronunciation is foreign to *true reading*. It is, rather, an impediment to the development of true reading. Such reading exercises constitute, as it were, a foreign body, which operates like a disease to prevent the development of the high intellectual activity which interprets the mysterious language of written symbols and arouses the child's enthusiasm with the fascinating revelations they can give. The eagerness of the

child to learn is curbed and cheated when he is compelled to stop his mind from working because his tongue refuses to act properly and must be laboriously trained to work right. This training, if begun at the proper time, when the child's whole psychic and nervous organism yearns for the perfection of the mechanism of speech, would have been a fascinating task; and once started along the right path, the pupil would have continued to follow it with alacrity and confidence. When the time comes for the intelligence to try its wings, its wings should be ready. What would happen to a painter, if at the moment of inspiration, he had to sit down and manufacture his brushes!

ANALYSIS

Our first publication on the methods used in the "Children's House" made clear two distinct operations involved in reading: the interpretation of the meaning and the pronunciation aloud of the "word." The stress we laid on that analysis as a guide to the development of reading was the result of actual experience. Those who followed this work during its initial stages saw how the children, when they read for the first time, interpreting the meaning of the words before them, did so without speaking,—reading, that is, mentally. Interpretation, in fact, is a question of mental concentration. Reading is an affair of the *intelligence*. The pronunciation aloud is quite a different thing, not only distinguished from the first process, but secondary to it. Talking aloud is a question of speech, involving first hearing and then the mechanical reproduction of sounds in articulate language. Its function is to bring into immediate communication

THIS PAGE IS LOCKED TO FREE MEMBERS

Purchase full membership to immediately unlock this page



HISTORY

Tens of thousands of important historical sources, many previously unobtainable, are now available for the first time with a Forgotten Books Full Membership.

Unlimited Access
\$8.99/month

Continue

*Fair usage policy applies

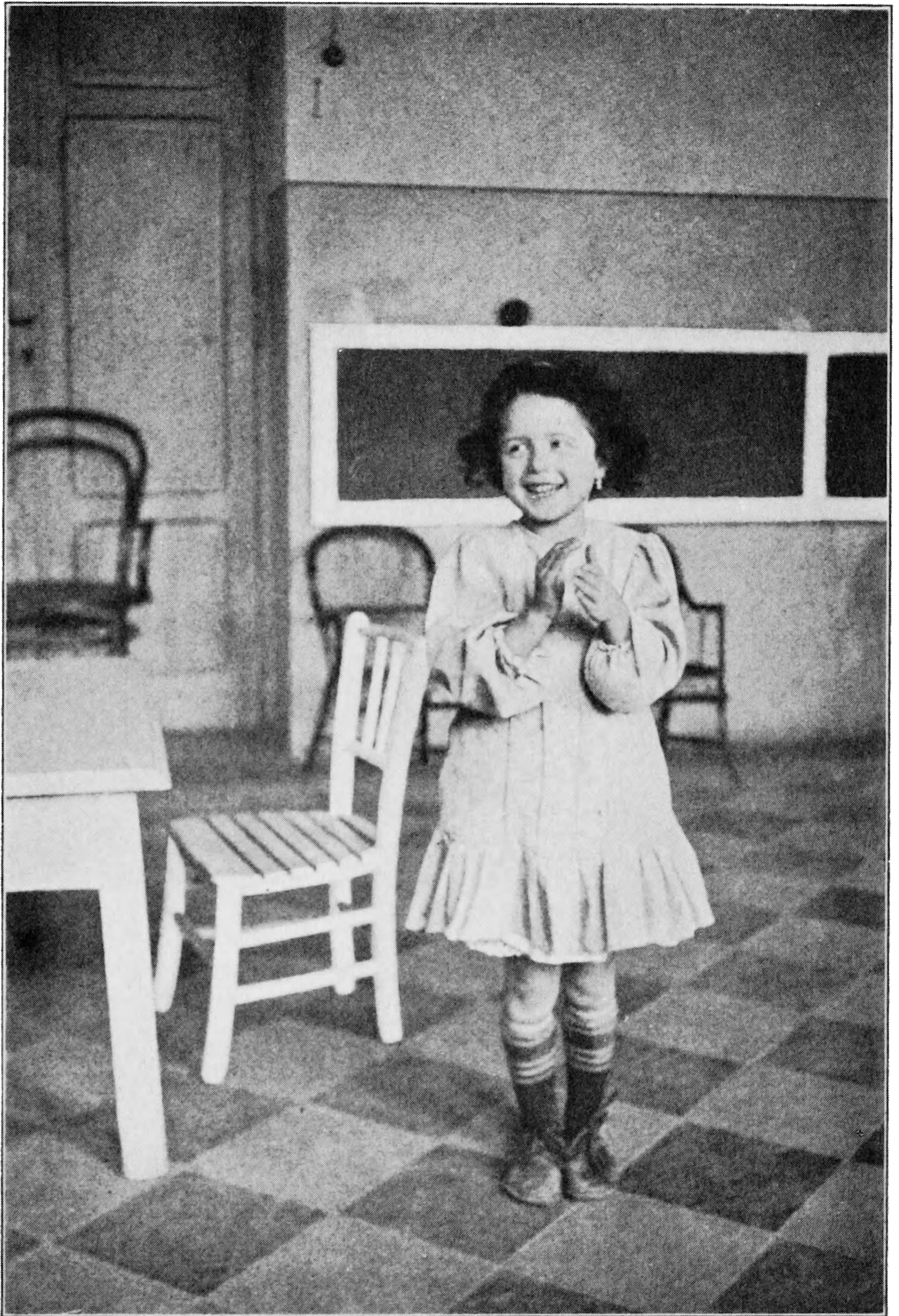

Interpreted reading: "Smile and clap your hands." The child reads silently an order written on a slip of paper; then proves that she understands by acting the direction given. (*A Montessori School in Italy.*)



Interpreted reading: "Take off your hat and make a low bow." (A Montessori School in Italy.)

reading is one of the rocks on which the rudderless ship of elementary education inevitably runs aground.

The experiments we have succeeded in conducting on the subject of reading are perhaps among the most complete we have made. We found the key to the problem when we discovered that the child passed from the mental reading of the words written on the cards directly to interpretation in action. This interpretation, ready and facile, as all the acts of children are, reveals to us what the child has understood and accordingly what he is capable of understanding. We have thus been able to obtain an experimental graduation of passages for reading, which on being gathered together, show the nature of the difficulties which successively present themselves to the child. The children have made for themselves specimen clauses and sentences which an expert grammarian could not have devised better for facilitating the study of language. As we went on with this work, we became more and more convinced that the study of grammar may be made a help in

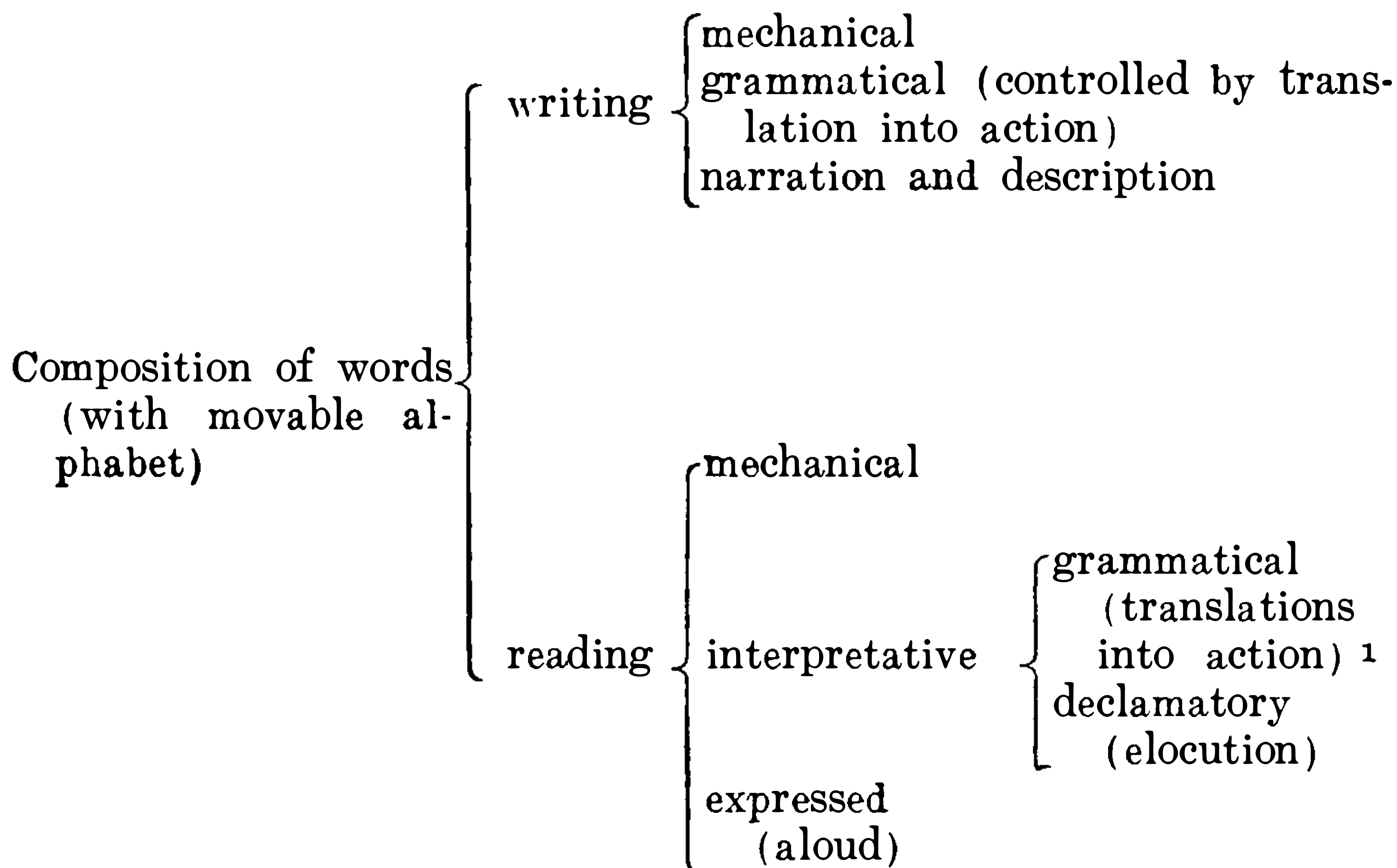

¹ The first readings consist of a special grammar and a dictionary.

THIS PAGE IS LOCKED TO FREE MEMBERS

Purchase full membership to immediately unlock this page

Know Your Bible

Forgotten Books' Full Membership provides unlimited access to more than 28,000 volumes of Christian literature for \$8.99/month

**HOLY
BIBLE**

Continue

*Fair use policy applies

dramatic art can the transmission of reading to a group of people be made possible.

It is clear that the oftener the exercise of identifying oneself with what is read is repeated and perfected, the greater the possibility of expression becomes. It follows that in the perfection of this art we should be less concerned with *timbre*, with tone of voice and gestures, all extrinsic aspects of this art, than with intense vivid *interpretation* which brings the child to an identification of himself with what he reads. And this interpretation will realize its objects if it is practised as a habit and as *a form of reading*.

The proof of correct interpretation was the child's ability to reproduce in action what was described in the words he read. Similarly, the proof of the interpretation in reading aloud is the repetition of the things heard by means of the spoken language. That is, the children, in order to prove to us that they have understood something read aloud, should be able to repeat in narrative form what they have heard.

The practical results of our efforts in this direction were very interesting to watch. Some children can say nothing. Others offer to tell the whole story. Their story is not clear or perhaps it is defective in some respect. Immediately other children are ready to correct the ones telling the story: "No, no, that's not what happened, that's not what happened," or, "Wait, you have forgotten something," and so on. In fact, to understand and to be able to narrate what has been understood is not the same thing. In telling a story there is a successive unfolding of very complex mental activities which are based on and added to the primal activity of "having understood." It

is a question again of the three different stages noted by us in the first lessons given to children:

First stage, the causing of the perception: (*That is red, that is blue*);

Second stage, the perfection of recognition: (*What is red or blue?*);

Third stage, the provocation of expression: (*What about this or that?*).

Thus, the child who succeeds in expressing, even in an imperfect way, what he has understood of the passage he has read, is in a more advanced state of development than other children who are unable to tell the story. However, these children who are not able to relate what they have heard said may very well be in the preceding stage in which they are capable of "recognition." These latter are the relentless critics, the constant "hecklers" of those who are trying to relate—"No, no,—that's not so," "You have forgotten this, or that." Let one of us teachers try to tell the story in the most perfect and complete manner, and these tiny impetuous hecklers listen to us in ecstasy, showing their approval in every form of approbation of which they are capable. By studying such manifestations in the children, we can get sufficient psychological data for determining what reading is adapted to children of different ages, the best ways of reading aloud, and the line of development followed by each child in that hidden mental world of his which is cut off from our gaze. But to derive these benefits from reading, it is perfectly clear that the children must be left absolutely *free* in the expression of what goes on in their minds.

According to the method used in ordinary schools a child is called upon to read aloud, and the teacher herself continually interrupts, either to correct the pronunciation, or

to assist by explanations and suggestions in the interpretation of the meaning. This is all useless for experimental purposes. We have no certain means of determining whether the pupil has understood either what he has read or the explanations of the teacher. Furthermore the corrections of pronunciation have centered the child's attention on this detail which is entirely without relation to the meaning of the text he is interpreting. Another situation not infrequently arises. A child is selected at random to tell in his own words what has been read. Often the selection is not made at random, but some pupil is called on because he has shown himself the most inattentive, the least interested in what is being done — the recitation thus becoming correctional in character! While the child is telling his story, there is a constant suppression of interruptions: "Hush, I did not call on you," "Wait till you are called on," "It is not polite to interrupt some one who is talking," etc. It is clear that the teacher will never learn anything about her pupils in this way.

This explains why, from the psychological point of view, our present-day schools have not been able to contribute anything new to a reformed scientific pedagogy of reading.

EXPERIMENTAL SECTION: READING ALOUD

Although we lay all possible stress on interpretative reading, we nevertheless put into the hands of the child a little reading book which he can go over by himself first in a low voice, and then, when he has grasped the meaning, aloud, provided he can express himself clearly and easily.

The simplicity of these texts occasions surprise when

THIS PAGE IS LOCKED TO FREE MEMBERS

Purchase full membership to immediately unlock this page



HISTORY

Tens of thousands of important historical sources, many previously unobtainable, are now available for the first time with a Forgotten Books Full Membership.

Unlimited Access
\$8.99/month

Continue

*Fair usage policy applies

fastening the hooks and eyes, buttoning and unbuttoning, tying and untying knots.

- Page 8. There are ten blocks for this tower, all of different sizes. First I spread them around on this carpet. It is great fun to put them together again, taking one after the other and choosing the largest each time.
- Page 9. I use the tower too in a balancing game. Just try to carry the tower around the room without letting it fall to pieces! Sometimes I succeed and then again I sometimes fail.
- Page 10. I like the long rods, too! I must put the rods near each other according to their length. I must be careful to place the blue sections near the blue ones and the red ones near the red. Thus, I build some pretty stairs with red and blue steps.
- Page 11. But to get a real stair case I use the brown prisms. These prisms are of different sizes. I put one beside the other according to size, and I get some fine stairs with ten steps.
- Page 12. I have also some solid insets of wood into which I fit little cylinders of different dimensions. They differ in length and breadth. The game is to put these cylinders in their places after looking at them and touching them carefully.
- Page 13. We often make mistakes in working with the insets. When we put a cylinder where it doesn't belong, we find that at the end of the game we have one cylinder left over and it won't fit in anywhere. Then the exercise becomes very exciting. We look at the inset carefully; we find the mistake and begin all over again. The most skilful pupils work on the insets with their eyes closed.
- Page 14. These colors are called: red, black, green, yellow, blue, brown, pink and violet.
- Page 15. I amuse myself by picking out and putting together pieces of the same color from the collection spread out over my table. I get thus a long strip of different colors.

- Page 16. We learn to arrange sixty-four different colors by gradations. We get eight beautiful blends of colors, each formed by eight tints of different tones. When we become skilful we can make a pretty rug with blending strips.
- Page 17. We also have two little chests full of pieces of cloth. The cloths are of all kinds from the roughest and hardest to the smoothest and softest: canvas, cotton, linen, wool, flannel, velvet, etc. If we keep our hands clean, we can learn to recognize all sorts of things with the tips of our fingers!
- Page 18. A child is blindfolded. He mixes the pieces of cloth with his little hands. He feels about among the pieces of cloth. At last he smiles and holds up his hands with two pieces of cloth, both alike. Though he could not see, the child has found out, just by using his fingers, that the two pieces were of the same cloth.
- Page 19. These are my plane insets. Here are the blue tablets. I must fit them into the frames, which have just enough room for them. I run two fingers, the forefinger and the middle-finger, around the edge of the tablet, and then around the edge of the frames. Next I fit the tablet into its proper place. After a little practise I can put the six tablets in their places even with my eyes blindfolded.
- Page 20. With the plane insets I have learned to recognize many figures: the square, the circle, the rectangle, the ellipse, the triangle, the oval, the pentagon, the hexagon, the heptagon, the octagon, the enneagon, the decagon. I learned all these hard names very easily because the insets are so amusing!

INTERPRETATIONS

Reading with the object of interpretation is conducted as in the first experiments of the "Children's House," with cards. From the graduated series we have prepared the child selects a card. He reads it mentally and then

executes the action indicated on the card. Our later experiments became very interesting when they were based upon a more rigorous method. When we gave a card describing two actions to a child of five years, he would execute only one of the actions. Take the following for example:

— She leaned over the back of a chair.

— She covered her face with her hands and wept.

The child would act out either the first sentence (*She leaned over the back of the chair*) or the second (*She covered her face with her hands and wept*). In spite of the fact that this child seemed extraordinarily eager to get the cards into his hands and to interpret them, those containing two sentences always aroused in him less enthusiasm than those containing a single sentence or indicating a single action (for instance, *The boy ran away as fast as he could*). In this latter case the enthusiasm of the little ones, their care in interpreting the action vividly, their eagerness to repeat it, their flushed faces and shining eyes, told us that at last we had the reading adapted to their psychology.

Our *first series* of readings accordingly is entirely “tested” or *experimental*. It is made up of simple sentences something like those analyzed in the lessons on grammar (Verb to Pronoun).

SERIES I

— She gazed slowly around the room.

— He looked at them out of the corners of his eyes.

— The boy ran away as fast as he could.

— She threw herself on her knees before him.

— The man paced slowly up and down the room.

— The little girl stood with lowered head.

THIS PAGE IS LOCKED TO FREE MEMBERS

Purchase full membership to immediately unlock this page

Know Your Bible

Forgotten Books'
Full Membership
provides unlimited
access to more than
28,000 volumes of
Christian literature for
\$8.99/month

**HOLY
BIBLE**

Continue

*Fair use policy applies

SERIES II

- He opened the door and came in.
- He left the room and locked the door behind him.
- He went on tiptoe to the door and carefully opened it.
- She covered her face with her hands and began to sob violently.
- She gave a cry of joy and ran to the door.
- She burst into a laugh and clapped her hands.
- He took off his cap and made a low bow.
- She shook her head sadly and smiled.
- He threw the window wide open and looked into the garden.
- He hurried to the table and rang the bell.
- With a sigh of relief he stretched himself out on the sofa, and lay there looking at the ceiling with his mouth open.
- He shut his eyes and fell asleep.

In the *third series*, there are sentences with one or more coordinate clauses.

SERIES III

- She opened the door, smoothed her hair slowly and came in.
- He went to the window, opened it a little and peered into the street.
- He closed the window, went back to his desk and then began to walk hurriedly up and down the room.
- The doctor bent over the sick man, felt his pulse with one hand and placed the other on his forehead.
- He took a key out of his pocket, opened the door and came in.
- She uttered a cry of joy, ran to her mother and sank on her knees before her.
- He put his left elbow on his knee, rested his forehead in his left hand and began to stroke his beard with his right.
- She leaned over the back of the chair, covered her face with her hands and wept.
- He went to the table, found the picture and joyfully took it in his hands.
- She took her handkerchief out of her pocket, unfolded it and wiped the tears from her eyes.

- The child was sleepy. He rested his head on his arms on the table and went to sleep.
- He looked toward the door fixedly, with an expression of terror on his face and waited for the man to come in.

SERIES IV

(Complex sentences with one subordinate clause)

- While he was making the drawing, he kept examining the flower very carefully.
- She covered her eyes with her hands, as if she were trying to collect her thoughts.
- She closed her eyes so that she could feel more intensely the softness of the piece of velvet.
- She looked tenderly after the little boy, till he disappeared through the door.
- When he had succeeded in turning the knob without making any noise, he stealthily opened the door and peered into the room.
- George held the book before his face so that no one could see him laughing.
- She walked slowly across the room and with bowed head, as though she were in great sorrow.
- The old man stroked the little boy's head as though he were much amused.
- After she had motioned to the child to be silent, the lady smilingly approached and took him by the hand.
- They stopped suddenly and listened, as though wondering what it could be.
- When Mary opened the door, George went to meet her with a cheery smile of welcome.

SERIES V

(Sentences somewhat more involved; descriptions more complex; an exact interpretation sometimes requires the pronunciation of words aloud)

- The child rose from her seat, and with her face buried in her handkerchief, walked slowly, sadly, toward the window.

- He lay back in his chair, his head sunk between his shoulders, while his arms were pressed tightly across his breast, as though he were cold.
- He dropped wearily into a chair and sat there looking at the floor, his right elbow on his knee and his chin resting on his hand.
- He stood at the open window, with figure erect, and his hands resting on the window-sill, while in deep breaths he took into his lungs the delicious fresh air that was coming into the room.
- The boy lowered his head, and rubbed his forehead with his hands as though he were trying to collect his thoughts.
- There she knelt, her face turned heavenward, her hands crossed in her lap, while her body drooped gently as though she were very, very tired.
- When he reached the door of his house, he hastily unlocked the door, opened it, went in, and carefully locked the door again behind him; and in his eagerness to confide his secret to some one he could trust, he went down the hall calling “Mother, Mother!”
- His eyes filled with tears as he went to the wall where the picture of his father hung, and there with his head resting on his arm against the wall, he sobbed bitterly.
- Rizpah spread the cloth on the ground at the foot of the tree, seated herself upon it, and with her arms resting limp upon her knees, her eyes set in unutterable woe, watched the birds and thought about her lost children.
- The man was lying, sprawling, on the couch, but he jumped up and ran to the door and angrily motioned to his servant to come to him.
- The old lady sat shivering near the stove, holding out her hands to get the warmth and nervously opening and closing them so that the tips of her fingers kept rubbing her palms.
- “I see,” thought the boy as he stood with folded arms looking fixedly at the floor.
- He took the handkerchief, examined it a moment and said: “It doesn’t belong to me!”
- He stooped over and picked up a pencil that was lying on the floor: “Pshaw,” said he, “it is broken!”

THIS PAGE IS LOCKED TO FREE MEMBERS

Purchase full membership to immediately unlock this page



HISTORY

Tens of thousands of important historical sources, many previously unobtainable, are now available for the first time with a Forgotten Books Full Membership.

Unlimited Access
\$8.99/month

Continue

*Fair usage policy applies

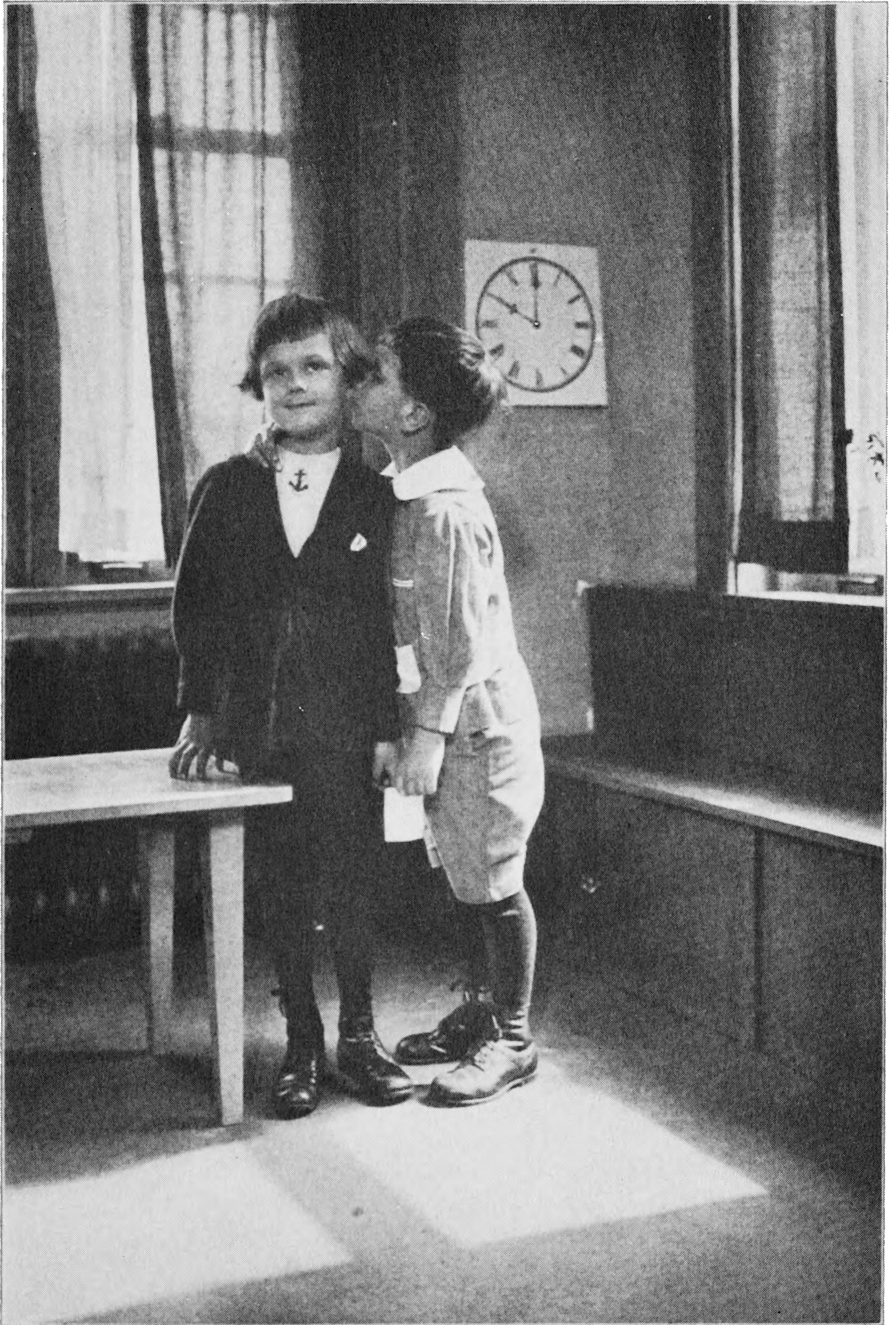

Interpreted reading: "Whisper to him." (*The Lenox School, Montessori Elementary Class, New York.*)



In a similar manner, the children act out or interpret poses and expressions in pictures. (*A Montessori School in Italy.*)

- under the pillow for his pistols: "Who goes there?" he shouted sternly.
- The child playfully drew his cap down over his eyes as though he were a very fierce bandit, and rushed into the room holding out his arm and pointing his fore-finger like a pistol.
 - As the ladies rode up, the old gentleman raised his hat and stood with bowed head till they had passed.
 - The young man picked up the glove from the floor, pressed it fervently to his lips and clasped it tenderly against his bosom, as though it were a priceless treasure.

SERIES VI

(More difficult interpretations with occasional speaking)

- Dunsey threw himself into a chair by the window, drew another chair before him, threw one leg over it, and began to beat on the window sill with the points of his fingers.
- Godfrey stood with his back to the fire, moving his fingers uneasily among the contents of his side-pockets and looking at the floor.
- Aaron replied by rubbing his head against his mother's skirt, passing the backs of his hands over his eyes and peeping through his fingers at Master Marner.
- Mr. Macey screwed up his mouth, leaned his head further on one side and twirled his thumbs rapidly, with his two hands resting on his lap and touching at the finger-tips.
- Silas sat with his elbows on his knees, his forehead pressed rigidly into his two palms, his eyes closed, deep sighs that were almost groans shaking his slender frame.
- The little tot squatted on the coat and spread out her hands to the fire; but the little eyes refused to stay open, and finally the golden head sank down upon the floor fast asleep.
- Presently the child slipped from his knee and began to walk about; but suddenly she fell into a sitting posture and began to pull at her little boots, as though she were trying to get at her toes.
- "At last," he said, stretching back in the arm chair, crossing

THIS PAGE IS LOCKED TO FREE MEMBERS

Purchase full membership to immediately unlock this page

Know Your Bible

Forgotten Books'
Full Membership
provides unlimited
access to more than
28,000 volumes of
Christian literature for
\$8.99/month

**HOLY
BIBLE**

Continue

*Fair use policy applies

as the little girl was turning to point out the road, one of the men seized her by the waist and lifted her from the ground. Lucia looked back over her shoulder terrified and gave a shriek. (Manzoni.)

(The children were delighted with this little action and rehearsed it over and over again.)

— With a start, Evangeline looked wildly about her: “Where is Gabriel?” she asked dazedly. “Where is Gabriel? Where is Gabriel?” “He is on that ship that is just sailing out of the harbor!” some one answered. For a few moments Evangeline stood shading her eyes with her palm, gazing after the vessel, fast disappearing into the horizon. At last she spoke half aloud: “I will follow you and find you wherever they may take you, Gabriel,” she said, as though taking a vow. Then she turned to the soldier and said: “Lead on to the boat, I am coming, I am coming.”

— “Give me the bow,” said Tell. Tell chose two arrows; one he fitted to the bow-string, the other he thrust into his girdle. Then for a moment he stood, a little bowed of shoulder, with his eyes downward: he was praying. You might have heard a leaf fall, so still was the place. Then Tell raised his head; his eyes were steady, his hands had become still; his face was like iron; he brought the cross bow to his shoulder and laid his eye to the feather of the shaft: “Twang,” the apple fell. A cheer arose from the crowd. Tell laid his hand upon the arrow in his girdle. “If the first had hurt my child,” he said, “this one by now would have been through your heart, O Gessler!”

The children by no means restrict themselves to acting out these little scenes and poses. In a second stage they read aloud all these slips which they have interpreted, and in view of the preparation they have had, their reading shows considerable power of expression. They tend to read the slips over and over again, many times, and not infrequently commit them to memory. To take advan-

tage of this new activity we got together a number of poems, making up a little book of children's verse. The pupils read them both mentally and aloud, ultimately committing them to memory and reciting them. Here are some specimens of our Italian collection:

IL BACIO

Dormiva nella cuna un bel bambino,
E la mamma lo stava a rimirare;
Voleva dargli il bacio del mattino,
Ma il bacio lo poteva risvegliare;
Svegliarlo non voleva, e con la
mano
Gli buttò cento baci da lontano.

UN SOGNO

Vidi una fata un giorno
Che avea le trecce d'oro
E un abito di perle
Più ricco d'un tesoro.

"Vieni con me," mi disse,
"Che ti farò regina."
"Non vengo, bella fata;
Io sto con la mamma."

LA NEVE

Lenta la neve fiocca, fiocca,
fiocca,
Senti, una culla dondola pian
piano.
Un bimbo piange, il piccol dito
in bocca,
Canta la vecchia, il mento in su
la mano.

LA GALLINA

Io vi domando se si può trovare
Un più bravo animal della gal-
lina.
Se non avesse il vizio di raspare

THE KISS

"A pretty child was sleeping
in its cradle; its mother was
looking at it. She wanted to
give it the morning kiss; but the
kiss might awaken it. To avoid
this, she threw it a thousand
kisses with her hand."

A DREAM

I saw a fairy one day, with
golden hair and a dress of pearls,
richer than a treasure.

"Come with me," the fairy
said, "and I'll make you a
queen." "I cannot, pretty fairy,"
I replied, "I must stay with
mother."

THE SNOW

The flakes of snow are falling,
falling, falling. Listen, a cradle
is gently, gently rocking; a baby
cries, his finger in his mouth;
the old nurse sings, her chin in
her hand.

THE HEN

I leave it to you: is there a
nicer animal than the hen? If
only she wouldn't scratch, I
would like to have one with me

Ne vorrei sempre aver una vicina.
Tutti i giorni a quell'ora: "Coccodè"!
Corri a guardar nel covo e l'ovo c'è!

LA POVERA BAMBINA

Disse: "Mia madre è morta!
Io son digiuna
E la stagion è cruda;
In terra a me non pensa anima alcuna:
Sono orfanella e ignuda."

IL PESCE

Un dì fuor della vasca del giardino
Guizzò imprudentemente un pesciolino.
Gigi lo vide, e tutto disperato
Gridò alla mamma: un pesce s'è annegato!

QUEL CHE POSSIEDE UN BAMBINO

Due piedi lesti lesti
per correre e saltare.
Due mani sempre in moto
per prendere e per fare.
La bocca piccolina
per tutto domandare.
Due orecchie sempre all'erta
intente ad ascoltare.
Due occhioni spalancati
per tutto investigare.
E un cuoricino buono
per molto, molto amare.

IL BUON ODORE

"Ma, bimbo mio, perchè
Sciupar questo bel fiore?"
"Cercavo il buon odore,
Non so capir dov'è."

LINA SCHWARZ.

all the time. Every day, at a certain hour: "Cut-cut-cut-cut-cadakut!"

Run and look in the nest, and an egg is there!

THE POOR ORPHAN CHILD

She said: "My mother is dead; I have nothing to eat; the weather is cold. There is no one left to think of me. I am a ragged orphan girl."

THE FISH

One day a little fish jumped imprudently out of the garden pool. Gigi saw it and all excitedly cried out: "Mamma, mamma, a fish has drowned himself."

A CHILD'S POSSESSIONS

Two little lively feet to run and jump with.
Two busy hands to take and do things.
One little mouth to ask questions with.
Two ears always awake to hear everything with.
Two bright eyes always open to see everything with.
One little heart to love with.

THE FLOWER'S FRAGRANCE

"Why spoil that pretty flower, my child?"
"I was looking for the sweet smell and I haven't been able to find it."

THIS PAGE IS LOCKED TO FREE MEMBERS

Purchase full membership to immediately unlock this page



HISTORY

Tens of thousands of important historical sources, many previously unobtainable, are now available for the first time with a Forgotten Books Full Membership.

Unlimited Access
\$8.99/month

Continue

*Fair usage policy applies

THE LITTLE COCK SPARROW

A little cock-sparrow sat on a
green tree,
And he chirruped, he chirruped,
so merry was he;
A naughty boy came with his
wee bow and arrow,
Determined to shoot this little
cock-sparrow.

“This little cock-sparrow shall
make me a stew,
And his giblets shall make me a
little pie too.”
“Oh, no!” said the sparrow, “I
won’t make a stew”;
So he flapped his wings and
away he flew.

BOOK OF KNOWLEDGE.

THE TREE

What do we do when we plant
the tree?
We plant the houses for you and
me;
We plant the rafters, the shin-
gle, the floors,
We plant the studding, the laths,
the doors,
The beams and siding — all parts
that be!
We plant the house when we
plant the tree.

HENRY ABBEY.

THE LAMB

Little lamb, who made thee?
Dost thou know who made thee,
Gave thee life and bade thee feed
By the stream and o’er the mead;
Gave thee clothing of delight,
Softest clothing woolly bright;
Gave thee such a tender voice,
Making all the vales rejoice?
Little lamb who made thee?
Dost thou know who made thee?

W. BLAKE.

Let dogs delight to bark and bite,
For God hath made them so;
Let bears and lions growl and
fight,
For ’tis their nature too.
But, children, you should never
let
Such angry passions rise:
Your little hands were never
made
To tear each others’ eyes.

WATTS.

The sunshine flickers through
the lace
Of leaves above my head,
And kisses me upon the face
Like Mother before bed.

The wind comes stealing o’er the
grass
To whisper pretty things;
And though I cannot see him
pass
I feel his careful wings.

STEVENSON.

After this preparation the children are able to “understand” what they read. All their difficulties in grasping the sentences and their most complicated constructions have been overcome. They have an insight into the grammatical form of language; and the construction of a sen-

tence, as well as the meaning of the words in it, interests them. There has been created within them a fund of suppressed energy which will very soon break forth into intense activity. In fact, in our school, after these exercises the passion for reading began to show itself. The children wanted "reading, reading, more reading." We got together hastily a few books but never enough to satisfy the eagerness of the children. We found a surprising lack of reading for little children in Italian. The American system of opening special rooms in public libraries for the use of little readers seems to me an excellent thing.

But to take full advantage of this awakened enthusiasm for reading and to cultivate at the same time the art of reading aloud we must not neglect another element in reading: audition.

AUDITION

When the child has advanced to some extent in the exercises of interpretation, the teacher may begin reading aloud. This should be done as artistically as possible. We recommend for the training of teachers not only a considerable artistic education in general but special attention to the art of reading. One of the differences between the traditional teacher of the past and the teachers we should like to create is that the former used to speak of an "art of teaching," which consisted of various devices to make the child learn, in spite of itself, what the teacher wanted to teach. Our teachers, rather, should be *cultivators* of the fine arts. For in our method art is considered a *means to life*. It is beauty in all its forms which helps the inner man to grow. We have repeatedly emphasized that both in the environment at school and in

the materials used, everything should be carefully considered in its artistic bearings, to provide ample room for development for all the phenomena of attention and persistence in work which are the secret keys of self-education. The Montessori teacher should be a cultivator of music, drawing and elocution, responsive to the harmony of things; she must, that is, have sufficient "good taste" to be able to lay out the school plant and keep it in condition; and sufficient delicacy of manner — the product of a sensitive nature — to be alive to all the manifestations of the child spirit.

In the matter of reading aloud the teacher has an important task to accomplish. We found the drawing hour best adapted for this work. It was our experience that it is easier to gain a hearing when the children are busy with something which does not require great concentration and which is not sustained by any particular inspiration. During the drawing lesson, in the placid silence which comes from work, and while the children are intent on their designs, the teacher may begin her reading aloud. It sometimes happens that the substance of what she reads will be sufficient to engage the interest of the whole school. But this is not always an easy task. It is more often the musical quality of the teacher's execution which will attract the little ones with a sense for art and bring them to that motionless attention which is the evidence of eager enjoyment. Possibly a really perfect reader might be able so to hold the whole group of children with some absorbing selection.

The readings we used were numerous and of great variety: fairy tales, short stories, anecdotes, novels, historical episodes. Specifically there were the tales of Andersen, some of the short stories of Capuana, the *Cuore* of De

THIS PAGE IS LOCKED TO FREE MEMBERS

Purchase full membership to immediately unlock this page

Know Your Bible

Forgotten Books' Full Membership provides unlimited access to more than 28,000 volumes of Christian literature for \$8.99/month

**HOLY
BIBLE**

Continue

*Fair use policy applies

out some of the scenes. They formed little companies of three or four and "acted" the episodes with a most impressive dramatic sense. One little girl was moved to bring to school a collection of all the Italian patriotic songs. It fascinated many of the children, who learned several by heart and sang them in chorus. In a word, the Italian Risorgimento came to live in those little hearts with a freshness it has long since lost in the souls of their elders. Many of the children wrote down their impressions of their own accord, often giving surprisingly original judgments. Finally they began to "take notes." They asked the teacher to give an outline of the principal events, which they took down in their copy-books. This whole experience corrected many of my own ideas on the teaching of history. I had thought of preparing moving-picture films and giving historical representations. But that, naturally, being beyond my resources, I had been compelled to give up the plan. The reading of De Luca's book was a revelation. To teach history to children it is sufficient to give a *living documented truth*. We need, not more cinematographs, but different school books. Children are much more sensible to the true and beautiful than we. They must be shown complete pictures of reality, which vividly suggest fact and situation. De Luca, moved by affection for his distant brothers, tried to write a book flaming both with truth and with love, which would awaken them and bring them back to live among us as Italians. Our task is the same. We must be filled with a similarly intense human zeal: we must call back to us the distant souls of the children. They too are brothers living far away in a distant country. We must arouse them, bring them back to us as partners in our own life.

After our readings from Itard's *Savage*, the parents

of the children kept coming to us with inquiries: "What have you been reading to our children? We should like to hear it ourselves." The little ones had told of hearing an extraordinary story about a child who had lived with the animals, beginning little by little to understand, to feel, to live like us. All the psychological details of his study, his attempts at education, seemed to have touched the children deeply. It occurred to us to take the older of such children to a "Children's House" and show them our educational method. They took the greatest interest in it, and some of them are now collaborators in the foundation of other "Children's Houses." Such children are able to follow the development of the child mind with extraordinary sympathy. However, if we reflect that the best teachers for children are children themselves, and that little tots like the company of another child much better than that of an adult, we need not be surprised at the downfall of another prejudice.

We have conceived of children according to a fantastic idea of our own, making of them a sort of human species distinct from that to which adults belong. As a matter of fact, they are our children, more purely human than we ourselves. The beautiful and the true have for them an intense fascination, into which they plunge as into something actually necessary for their existence.

The results here witnessed led us to many a reflection. We succeeded in teaching history and even pedagogy by means of "reading." And, in truth, does not reading embrace everything? Travel stories teach geography; insect stories lead the child into natural science; and so on. The teacher, in short, can use reading to introduce her pupils to the most varied subjects; and the moment they have been thus started, they can go on to any limit



Interpreted reading: "She was sleepy; she leaned her arms on the table, her head on her arms, and went to sleep." Notice the slip of paper which the child has just read. (*The Lenox School, Montessori Elementary Class, New York.*)

THIS PAGE IS LOCKED TO FREE MEMBERS

Purchase full membership to immediately unlock this page



HISTORY

Tens of thousands of important historical sources, many previously unobtainable, are now available for the first time with a Forgotten Books Full Membership.

Unlimited Access
\$8.99/month

Continue

*Fair usage policy applies

guided by the single passion for reading. Our task is to offer the child the instruments of education, to keep pure within him the springs of his intellectual growth, of his life of feeling. The rest follows as a matter of course. As the ancients said: “*Necessary* education is the three ‘r’s’: reading, writing and arithmetic,” for these are things which the child cannot discover by himself. We can only add that “method” must be scientifically determined only at the points where it becomes necessary to assist the “formation of man,” that he may develop his activities by strengthening them and not by repressing them, that he may receive essential help without losing any of the pure freshness of his interior activities. But this does not mean that “a rigorous method must guide the child at all times and in every step that he takes.” When he has become strong and is in possession of his tools for discovery, he will be able to uncover many of life’s secrets by himself. We tied the child to the materials in his sensory exercises, but we left him free to explore his environment. This must be the method for all his later steps in advance: he must be given the instrument and the strength to use it, and then left free to find things out for himself.

The fondness of children for reading and their preference for the “true” is something already demonstrated by experiments conducted elsewhere. I may refer here to the investigations on readings for children conducted by the “Education” section of the Federation for School Libraries of the province of Emilia (Italy). The questionnaire was as follows:

Do you remember what books you have read and which you liked best?

How did you get them?

Do you know the title of some book you would like to read?

Do you prefer fairy-tales, or rather stories of true or probable facts? Why?

Do you prefer sad or humorous stories?

Do you like poetry?

Do you like stories of travel and adventure?

Do you subscribe to any weekly or monthly newspaper? If so, to which?

If your mother were to offer you a choice between a subscription to a weekly or a monthly and an illustrated book, which would you take? And why?

The answers, very carefully sifted, showed that the vast majority of children preferred readings which dealt with fact. Here are some of the reasons alleged by the children in support of their preference for "truth": "Facts teach me something; fairy-tales are too improbable; true stories don't upset my thinking; true stories teach me history; true stories always convey some good idea; fairy-stories give me many desires impossible to satisfy; many good ideas come from actual experiences; fantastic tales make me think too much about supernatural things"; etc., etc. In favor of the fairy-tales we find: "They amuse me in hours free from work; I like to be in the midst of fairies and enchantments"; etc. Those who preferred sad or serious stories justified themselves as follows: "I feel that I am a better person, and realize better the wrong I do; I feel that my disposition becomes more kindly; they arouse in me feelings of kindness and pity." Many supported their preference for humorous tales on the ground that "when I read them, I am able to forget my own little troubles." In general, a great majority denied any educational value to joy and humor. In this conviction — or rather this feeling — so widely diffused among children, have we not evidence that something must be wrong in the kind of education we have been giving them?

PART III
ARITHMETIC

THIS PAGE IS LOCKED TO FREE MEMBERS

Purchase full membership to immediately unlock this page

Know Your Bible

Forgotten Books'
Full Membership
provides unlimited
access to more than
28,000 volumes of
Christian literature for
\$8.99/month

**HOLY
BIBLE**

Continue

*Fair use policy applies

ARITHMETICAL OPERATIONS

NUMBERS: 1 — 10

The children already had performed the four arithmetical operations in their simplest forms, in the "Children's Houses," the didactic material for these having consisted of the rods of the long stair which gave empirical representation of the numbers 1, 2, 3, 4, 5, 6, 7, 8, 9, 10. By means of its divisions into sections of alternating colors, red and blue, each rod represented the quantity of unity for which it stood; and so the entrance into the complex and arduous field of numbers was thus rendered easy, interesting, and attractive by the conception that collective number can be represented by a *single* object containing signs by which the relative quantity of unity can be recognized, instead of by *a number of different* units, represented by the figure in question. For instance, the fact that five may be represented by a single object with five distinct and equal parts instead of by five distinct objects which the mind must reduce to a concept of number, saves mental effort and clarifies the idea.]

It was through the application of this principle by means of the rods that the children succeeded so easily in accomplishing the first arithmetical operations: $7 + 3 = 10$; $2 + 8 = 10$; $10 - 4 = 6$; etc.

The long stair material is excellent for this purpose. But it is too limited in quantity and is too large to be

handled easily and used to good advantage in meeting the demands of a room full of children who already have been initiated into arithmetic. [Therefore, keeping to the same fundamental concepts, we have prepared smaller, more abundant material, and one more readily accessible to a large number of children working at the same time.]

[This material consists of beads strung on wires: i.e., bead bars representing respectively 1, 2, 3, 4, 5, 6, 7, 8, 9, 10. The beads are of different colors. The 10-bead bar is orange; 9, dark blue; 8, lavender; 7, white; 6, gray; 5, light blue; 4, yellow; 3, pink; 2, green; and there are separate beads for unity.¹ The beads are opalescent; and the white metal wire on which they are strung is bent at each end, holding the beads rigid and preventing them from slipping.

There are five sets of these attractive objects in each box; and so each child has at his disposal the equivalent of five sets of the long stairs used for his numerical combinations in the earliest exercise. The fact that the rods are small and so easily handled permits of their being used at the small tables.

This very simple and easily prepared material has been extraordinarily successful with children of five and a half years. They have worked with marked concentration, doing as many as sixty successive operations and filling whole copybooks within a few days' time. Special quadrille paper is used for the purpose; and the sheets are ruled in different colors: some in black, some in red, some

¹ At the present time, because of the difficulty of getting beads of certain colors, owing to war conditions, the following colors have been approved by Dr. Montessori to replace those originally used: 10-bead bar, gold; 9, dark blue; 8, white; 7, light green; 6, light blue; 5, yellow; 4, pink; 3, green; 2, yellow-green; 1, gold. These same colors are retained for the bead squares and the bead cubes. They will be supplied by The House of Childhood, 16 Horatio Street, New York.

in green, some in blue, some in pink, and some in orange. The variety of colors helps to hold the child's attention: after filling a sheet lined in red, he will enjoy filling one lined in blue, etc.

Experience has taught us to prepare a large number of the ten-bead bars; for the children will choose these from all the others, in order to count the tens in succession: 10, 20, 30, 40, etc. To this first bead material, therefore, we have added boxes filled with nothing but ten-bead bars. There are also small cards on which are written 10, 20, etc. The children put together two or more of the ten-bead bars to correspond with the number on the cards. This is an initial exercise which leads up to the multiples of 10. By superimposing these cards on that for the number 100 and that for the number 1000, such numbers as 1917 can be obtained.

* { The "bead work" became at once an established element in our method, scientifically determined as a conquest brought to maturity by the child in the very act of making it. Our success in amplifying and making more complex the early exercises with the rods has made the child's mental calculation more rapid, more certain, and more comprehensive. Mental calculation develops spontaneously, as if by a law of conservation tending to realize the "minimum of effort." Indeed, little by little the child ceases counting the beads and recognizes the numbers by their color: the dark blue he knows is 9, the yellow 4, etc. Almost without realizing it he comes now to count by *colors* instead of by *quantities* of beads, and thus performs actual operations in mental arithmetic. } As soon as the child becomes conscious of this power, he joyfully announces his transition to the higher plane, exclaiming, { I can count in my head and I can do it more

THIS PAGE IS LOCKED TO FREE MEMBERS

Purchase full membership to immediately unlock this page



HISTORY

Tens of thousands of important historical sources, many previously unobtainable, are now available for the first time with a Forgotten Books Full Membership.

Unlimited Access
\$8.99/month

Continue

*Fair usage policy applies

same quantity which formerly impressed the child by its length is now, in its broad, folded form, presented as a *surface* quantity.

Now all may be placed on a small table, one below the other: first the single bead, then the ten-bead bar, then the "hundred chain," and finally the broad strip of the "thousand chain."

Any teacher who has asked herself how in the world a child may be taught to express in numerical terms quantitative proportions perceived through the eye, has some idea of the problem that confronts us. However, our children set to work patiently counting bead by bead from 1 to 100. Then they gathered in two's and three's about the "thousand chain," as if to help one another in counting it, undaunted by the arduous undertaking. They counted one hundred; and after one hundred, what? One hundred one. And finally two hundred, two hundred one. One day they reached seven hundred. "I am tired," said the child. "I'll mark this place and come back tomorrow."

"Seven hundred, seven hundred — Look!" cried another child. "There are seven — *seven* hundreds! Yes, yes; count the chains! Seven hundred, eight hundred, nine hundred, one thousand. Signora, signora, the 'thousand chain' has ten 'hundred chains'! Look at it!" And other children, who had been working with the "hundred chain," in turn called the attention of *their* comrades: "Oh, look, look! The 'hundred chain' has ten ten-bead bars!"

Thus we realized that the numerical concept of tens, hundreds, and thousands was given by presenting these chains to the child's intelligent curiosity and by respecting the spontaneous endeavors of his free activities.

And since this was our experience with most of the children, one easily can see how simple a suggestion would be necessary if the deduction did not take place in the case of some exceptional child. In fact, to make the idea of decimal relations apparent to a child, it is sufficient to direct his attention to the material he is handling. The teacher experienced in this method knows how to wait; she realizes that the child needs to exercise his mind constantly and slowly; and if the inner maturation takes place naturally, "intuitive explosions" are bound to follow as a matter of course. The more we allow the children to follow the interests which have claimed their fixed attention, the greater will be the value of the results.

COUNTING-FRAMES

The direct assistance of the teacher, her clear and brief explanation, is, however, essential when she presents to the child another new material, which may be considered "symbolic" of the decimal relations. This material consists of two very simple bead counting-frames, similar in size and shape to the dressing-frames of the first material. They are light and easily handled and may be included in the individual possessions of each child. The frames are easily made and are inexpensive.

One frame is arranged with the longest side as base, and has four parallel metal wires, each of which is strung with ten beads. The three top wires are equidistant but the fourth is separated from the others by a greater distance, and this separation is further emphasized by a brass nail-head fixed on the left hand side of the frame. The frame is painted one color above the nail-head and another color below it; and on this side of the frame, also, numerals corresponding to each wire are marked. The

numeral opposite the top wire is 1, the next 10, then 100, and the lowest, 1000.

We explain to the child that each bead of the first wire is assumed to stand for one, or unity, as did the separate beads they have had before; but each bead of the second wire stands for ten (or for one of the ten-bead bars); the value of each bead of the third wire is one hundred and represents the "hundred chain"; and each bead on the last wire (which is separated from the others by the brass nail-head) has the same value as a "thousand chain."¹

At first it is not easy for the child to understand this symbolism, but it will be less difficult if he previously has worked over the chains, counting and studying them without being hurried. When the concept of the relationship between unity, tens, hundreds, and thousands has matured spontaneously, he more readily will be able to recognize and use the symbol.

Specially lined paper is designed for use with these frames. This paper is divided lengthwise into two equal parts, and on both sides of the division are vertical lines of different colors: to the right a green line, then a blue, and next a red line. These are parallel and equidistant. A vertical line of dots separates this group of three lines from another line which follows. On the first three lines from right to left are written respectively the units, tens, and hundreds; on the inner line the thousands.

The right half of the page is used entirely and exclusively to clarify this idea and to show the relationship of written numbers to the decimal symbolism of the counting-frame.

¹ It would, perhaps, be better in this first counting-frame to have the beads not only of different colors, but of different sizes, according to the value of the wires, as was suggested to me by a Portuguese professor who had been taking my course.

THIS PAGE IS LOCKED TO FREE MEMBERS

Purchase full membership to immediately unlock this page

Know Your Bible

Forgotten Books'
Full Membership
provides unlimited
access to more than
28,000 volumes of
Christian literature for
\$8.99/month

**HOLY
BIBLE**

Continue

*Fair use policy applies

tens line we must of necessity pass to the hundreds line, because ten tens equal one hundred. Finally, when 9 in the hundreds line has been written, we must pass to the thousands line for the same reason.

The units from 1 to 9 are written on the line farthest to the right; on the next line to the left are written the tens (from 1 to 9); and on the third line, the hundreds (from 1 to 9). Thus always we have the numbers 1 to 9; and it cannot be otherwise, for any more would cause the figure itself to change position. It is this fact that the child must quietly ponder over and allow to ripen in his mind.

It is the nine numbers that change position in order to form all the numbers that are possible. Therefore, it is not the number in itself but its *position* in respect to the other numbers which gives it the value now of one, now of ten, now of one hundred or one thousand. Thus we have the symbolic translation of those real values which increase in so prodigious a way and which are almost impossible for us to conceive. One line of ten thousand beads is seventy meters long! Ten such lines would be the length of a long street! Therefore we are forced to have recourse to symbols. How very important this *position* occupied by the number becomes!

How do we indicate the position and hence the value of a certain number with reference to other numbers? As there are not always vertical lines to indicate the relative position of the figure, *the requisite number of zeros are placed to the right of the figure!*

The children already know, from the "Children's House," that zero has no value and that it can give no value to the figure with which it is used. It serves merely to show the position and the value of the figure written at

its left. Zero does not give value to 1 and so make it become 10: the zero of the number 10 indicates that the figure 1 is not a unit but is in the next preceding position — that of the tens — and means therefore one ten and not one unit. If, for instance, 4 units followed the 1 in the tens position, then the figure 4 would be in the units place and the 1 would be in the tens position.

The “Children’s House” child already knows how to write ten and even one hundred; and it is now very easy for him to write, with the aid of zeros, and *in columns*, from 1 to 1000: 1, 2, 3, 4, 5, 6, 7, 8, 9; 10, 20, 30, 40, 50, 60, 70, 80, 90; 100, 200, 300, 400, 500, 600, 700, 800, 900; 1,000. When the child has learned to count well in this manner, he can easily read any number of four figures.

Let us now make up a number on the counting-frame; for example, 4827. We move four beads to the left on the thousands-wire, eight on the hundreds-wire, two on the tens-wire, and seven on the units-wire; and we read, four thousand eight hundred and twenty-seven. This number is written by placing the numbers *on the same line* and in the mutually relative order determined by the symbolic positions for the decimal relations, 4827.

We can do the same with the date of our present year, writing the figures on the left-hand side of the paper as indicated: 1917.

Let us compose 2049 on the symbolic number frame. Two of the thousand-beads are moved to the left, four of the ten-beads, and nine of the unit-beads. On the hundreds-wire there is nothing. Here we have a good demonstration of the function of zero, which is to occupy the places that are empty on this chart.

Similarly, to form the number 4700 on the frame, four

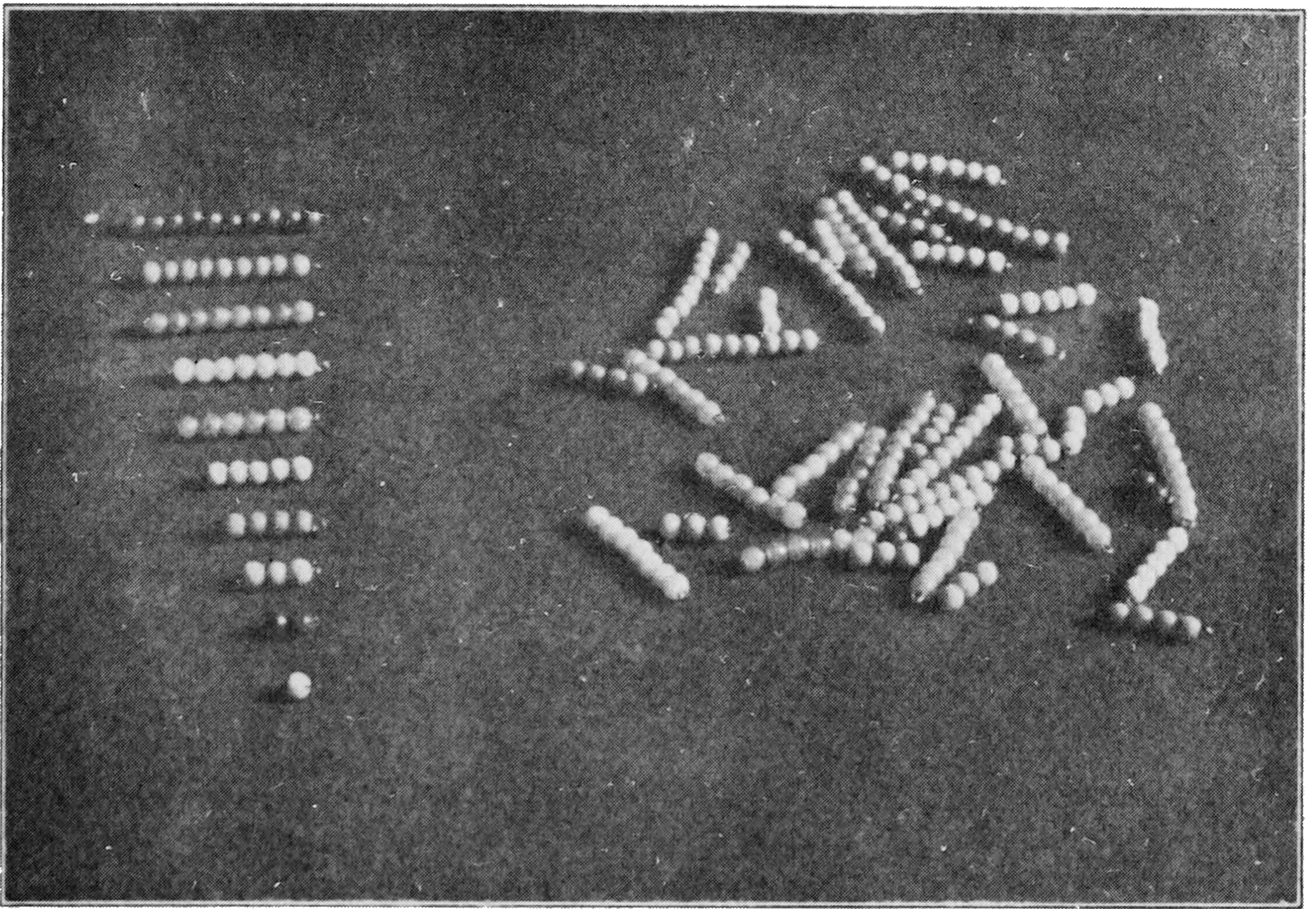

The bead material used for addition and subtraction. Each of the nine numbers is of different colored beads.



Counting and calculating by means of the bead chains. (*A Montessori School in Italy.*)

THIS PAGE IS LOCKED TO FREE MEMBERS

Purchase full membership to immediately unlock this page



HISTORY

Tens of thousands of important historical sources, many previously unobtainable, are now available for the first time with a Forgotten Books Full Membership.

Unlimited Access
\$8.99/month

Continue

*Fair usage policy applies

thousand-beads are moved to the left and seven hundred-beads, the tens-wire and the units-wire remaining empty. In transcribing this number, these empty places are filled by zeros — a figure of no value in itself.

When the child fully understands this process he makes up many exercises of his own accord and with the greatest interest. He moves beads to the left at random, on one or on all of the wires, then interprets and writes the number on the sheets of paper purposely prepared for this. When he has comprehended the position of the figures and performed operations with numbers of several figures he has mastered the process. The child need only be left to his auto-exercises here in order to attain perfection.

Very soon he will ask to go beyond the thousands. For this there is another frame, with seven wires representing respectively units, tens, and hundreds; units, tens and hundreds of the thousands; and a million.

This frame is the same size as the other one but in this the shorter side is used as the base and there are seven wires instead of four. The right-hand side is marked by three different colors according to the groups of wires. The units, tens and hundreds wires are separated from the three thousands wires by a brass tack, and these in turn are separated in the same manner from the million wire.

The transition from one frame to the other furnishes much interest but no difficulty. Children will need very few explanations and will try by themselves to understand as much as possible. The large numbers are the most interesting to them, therefore the easiest. Soon their copybooks are full of the most marvelous numbers; they have now become dealers in millions.

For this frame also there is specially prepared paper.

On the right-hand side the child writes the numbers corresponding to the frame, counting from one to a million: 1, 2, 3, 4, 5, 6, 7, 8, 9; 10, 20, 30, 40, 50, 60, 70, 80, 90; 100, 200, 300, 400, 500, 600, 700, 800, 900; 1,000, 2,000, 3,000, 4,000, 5,000, 6,000, 7,000, 8,000, 9,000; 10,000, 20,000, 30,000, 40,000, 50,000, 60,000, 70,000, 80,000, 90,000; 100,000, 200,000, 300,000, 400,000, 500,000, 600,000, 700,000, 800,000, 900,000; 1,000,000.

After this the child, moving the beads to the left on one or more of the wires, tries to read and then to write on the left half of the paper the numbers resulting from these haphazard experiments. For example, on the counting-frame he may have the number 6,206,818, and on the paper the numbers 1,111, 111; 8,640,850; 1,500,000; 3,780,000; 5,840,714; 720,000; 500,000; 430,000; 35,840; 80,724; 15,229; 1,240.

When we come to add and subtract numbers of several figures and to write the results in column, the facility resulting from this preparation is something astonishing.

II

THE MULTIPLICATION TABLE

MATERIAL: The material for the multiplication table is in several parts. There is a square cardboard with a hundred sockets or indentures (ten rows, ten in a row), and into each of these indentures may be placed a bead. At the top of the square and corresponding to each vertical line of indentures are printed the numbers 1, 2, 3, 4, 5, 6, 7, 8, 9, 10. At the left is an opening into which may be slipped a small piece of cardboard upon which are printed in red the numbers from 1 to 10. This cardboard serves as the multiplicand; and it can be changed, for there are ten of these slips, bearing the ten different numbers. In the upper left-hand corner is a small indenture for a little red marker, but this detail is merely secondary. This arithmetic board is a white square with a red border; and with it comes an attractive box containing a hundred loose beads.

The exercise which is done with this material is very simple. Suppose that 6 is to be multiplied by the numbers in turn from 1 to 10: 6×1 ; 6×2 ; 6×3 ; 6×4 ; 6×5 ; 6×6 ; 6×7 ; 6×8 ; 6×9 ; 6×10 . Opposite the sixth horizontal line of indentures, in the small opening at the left is slipped the card bearing the number 6. In multiplying the 6 by 1, the child performs two operations: first, he puts the red marker above the printed 1 at the top of the board, and then he puts six beads (cor-

THIS PAGE IS LOCKED TO FREE MEMBERS

Purchase full membership to immediately unlock this page

Know Your Bible

Forgotten Books' Full Membership provides unlimited access to more than 28,000 volumes of Christian literature for \$8.99/month

**HOLY
BIBLE**

Continue

*Fair use policy applies

making a hundred sheets with each set of multiplication material. The accompanying cut shows a sheet prepared for the multiplication of number 3.

Everything is ready on the printed sheet; the child has only to write the results which he obtains by adding the beads in columns of three each. If he makes no error he will write: 3, 6, 9, 12, 15, 18, 21, 24, 27, 30.

In this way he will work out and write down the whole series from 1 to 10; and as there are ten copies of each sheet, he can repeat each exercise ten times.

Thus the child learns by memory each of these multiplications. And we find that he helps himself to memorize even in other ways. He walks up and down holding the multiplication sheet, which he looks at from time to time. It is a sheet which he himself has filled, and he may be memorizing seven times six, forty-two; seven times seven, forty-nine; seven times eight, fifty-six, etc.

This material for the multiplication table is one of the most interesting to the children. They fill six or seven sets, one after the other, and work for days and weeks on this one exercise. Almost all of them ask to take it home with them. With us, the first time the material was presented a small uprising took place, for they all wished to carry it away with them. As this was not permitted the children implored their mothers to buy it for them, and it was with difficulty that we made them understand that it was not on the market and therefore could not be purchased. But the children could not give up the idea. One older girl headed the rebellion. "The Dottoressa wants to try an experiment with us," she said. "Well, let's tell her that unless she gives us the material for the multiplication table we won't come to school any more."

This threat in itself was impolite, and yet it was interesting; for the multiplication table, the bug-bear of all children, had become so attractive and tempting a thing that it had made wolves out of my lambs!

When the children have repeatedly filled a whole series of these blanks, with the aid of the material, they are given a test-card by means of which they may compare their work for verification, and see whether they have made any errors in their multiplication. Table by table, number by number, they do the work of comparing each result with the number which corresponds to it in each one of the ten columns. When this has been done carefully, the children possess their own series, the accuracy of which they are able to guarantee themselves.

MULTIPLICATION TABLE

PRESENTING THE COMBINATIONS OF NUMBERS IN THE
PROGRESSIVE SERIES FROM 1 TO 10

1 × 1 = 1	2 × 1 = 2	3 × 1 = 3	4 × 1 = 4	5 × 1 = 5
1 × 2 = 2	2 × 2 = 4	3 × 2 = 6	4 × 2 = 8	5 × 2 = 10
1 × 3 = 3	2 × 3 = 6	3 × 3 = 9	4 × 3 = 12	5 × 3 = 15
1 × 4 = 4	2 × 4 = 8	3 × 4 = 12	4 × 4 = 16	5 × 4 = 20
1 × 5 = 5	2 × 5 = 10	3 × 5 = 15	4 × 5 = 20	5 × 5 = 25
1 × 6 = 6	2 × 6 = 12	3 × 6 = 18	4 × 6 = 24	5 × 6 = 30
1 × 7 = 7	2 × 7 = 14	3 × 7 = 21	4 × 7 = 28	5 × 7 = 35
1 × 8 = 8	2 × 8 = 16	3 × 8 = 24	4 × 8 = 32	5 × 8 = 40
1 × 9 = 9	2 × 9 = 18	3 × 9 = 27	4 × 9 = 36	5 × 9 = 45
1 × 10 = 10	2 × 10 = 20	3 × 10 = 30	4 × 10 = 40	5 × 10 = 50
6 × 1 = 6	7 × 1 = 7	8 × 1 = 8	9 × 1 = 9	10 × 1 = 10
6 × 2 = 12	7 × 2 = 14	8 × 2 = 16	9 × 2 = 18	10 × 2 = 20
6 × 3 = 18	7 × 3 = 21	8 × 3 = 24	9 × 3 = 27	10 × 3 = 30
6 × 4 = 24	7 × 4 = 28	8 × 4 = 32	9 × 4 = 36	10 × 4 = 40
6 × 5 = 30	7 × 5 = 35	8 × 5 = 40	9 × 5 = 45	10 × 5 = 50
6 × 6 = 36	7 × 6 = 42	8 × 6 = 48	9 × 6 = 54	10 × 6 = 60
6 × 7 = 42	7 × 7 = 49	8 × 7 = 56	9 × 7 = 63	10 × 7 = 70
6 × 8 = 48	7 × 8 = 56	8 × 8 = 64	9 × 8 = 72	10 × 8 = 80
6 × 9 = 54	7 × 9 = 63	8 × 9 = 72	9 × 9 = 81	10 × 9 = 90
6 × 10 = 60	7 × 10 = 70	8 × 10 = 80	9 × 10 = 90	10 × 10 = 100

The children should write down on the following form, in the separate columns, their verified results: under the 2, the column of the 2's; under the 3, the column of the 3's; under the 4, the column of the 4's, etc.

	1	2	3	4	5	6	7	8	9	10	
2											
3											
4											
5											
6											
7											
8											
9											
10											

Then they get the following table, which is identical with the test cards included in the material. It is a summary of the multiplication table — the famous Pythagorean table.

THE MULTIPLICATION TABLE

1	2	3	4	5	6	7	8	9	10
2	4	6	8	10	12	14	16	18	20
3	6	9	12	15	18	21	24	27	30
4	8	12	16	20	24	28	32	36	40
5	10	15	20	25	30	35	40	45	50
6	12	18	24	30	36	42	48	54	60
7	14	21	28	35	42	49	56	63	70
8	16	24	32	40	48	56	64	72	80
9	18	27	36	45	54	63	72	81	90
10	20	30	40	50	60	70	80	90	100

THIS PAGE IS LOCKED TO FREE MEMBERS

Purchase full membership to immediately unlock this page



HISTORY

Tens of thousands of important historical sources, many previously unobtainable, are now available for the first time with a Forgotten Books Full Membership.

Unlimited Access
\$8.99/month

Continue

*Fair usage policy applies

III

DIVISION

MATERIAL: The same material may be used for division, except the blanks, which are somewhat different.

Take any number of beads from the box and count them. Let us suppose that we have twenty-seven. This number is written in the vacant space at the left-hand side of the division blank.

DIVISION		REMAINDER
	: 2 =
	: 3 =
	: 4 =
	: 5 =
27	: 6 =
	: 7 =
	: 8 = 3	3
	: 9 = 3	
	: 10 = 2	7

Then taking the box of beads and the arithmetic board with the hundred indentures we proceed to the operation.

Let us first divide 27 by 10. We place ten beads in a vertical line under the 1; then in the next row ten more beads under the 2. The beads, however, are not sufficient to fill the row under the 3. Now on the paper prepared for division we write 2 on a line with the 10

to the left of the vertical line, and to the right of the same vertical line we write the remainder 7.

To divide 27 by 9, nine beads are counted out in the first row, then nine in the second row under the 2, and still another nine under the 3. There are no beads left over. So the figure 3 is written after the equal-sign (=) on a line with 9.

To divide 27 by 8 we count out eight beads, place them in a row under the 1, and then fill like rows under the 2 and the 3; in the fourth row there are only three beads. They are the remainder. And so on.

A package of one hundred division blanks comes in an attractive dark green cover tied with a silk ribbon. The multiplication blanks, with their tables for comparison and summary tables, come in a parchment envelope tied with leather strings.

DIVISION	REMAINDER
: 2 =	
: 3 =	
: 4 =	
: 5 =	
: 6 =	
: 7 =	
: 8 =	
: 9 =	
: 10 =	

IV

OPERATIONS IN SEVERAL FIGURES

By this time the child can easily perform operations with numbers of two or more figures, for he possesses all the materials necessary and is already prepared to make use of them.

For this work we have for the first three operations, addition, subtraction, and multiplication, a counting-frame; and for division a more complicated material which will be described later on.

ADDITION

Addition on the counting frame is a most simple operation, and therefore is very attractive. Let us take, for example, the following:

$$\begin{array}{r} 1320 + \\ \quad 435 \\ \hline = \end{array}$$

First we slide over the beads to represent the first number: 1 on the thousands-wire, 3 on the hundreds-wire, and 2 on the tens-wire. Then we place next to them the beads representing the second number: 4 on the hundreds-wire, 3 on the tens-wire, and 5 on the units-wire. Now there remains nothing to be done except to write the number shown by the beads in their present position: 1755.

THIS PAGE IS LOCKED TO FREE MEMBERS

Purchase full membership to immediately unlock this page

Know Your Bible

Forgotten Books' Full Membership provides unlimited access to more than 28,000 volumes of Christian literature for \$8.99/month

HOLY BIBLE

Continue

*Fair use policy applies



This shows the second counting-frame used in arithmetic. The child is writing the number she has just formed on her frame. (*The Rivington Street Montessori School, New York.*)

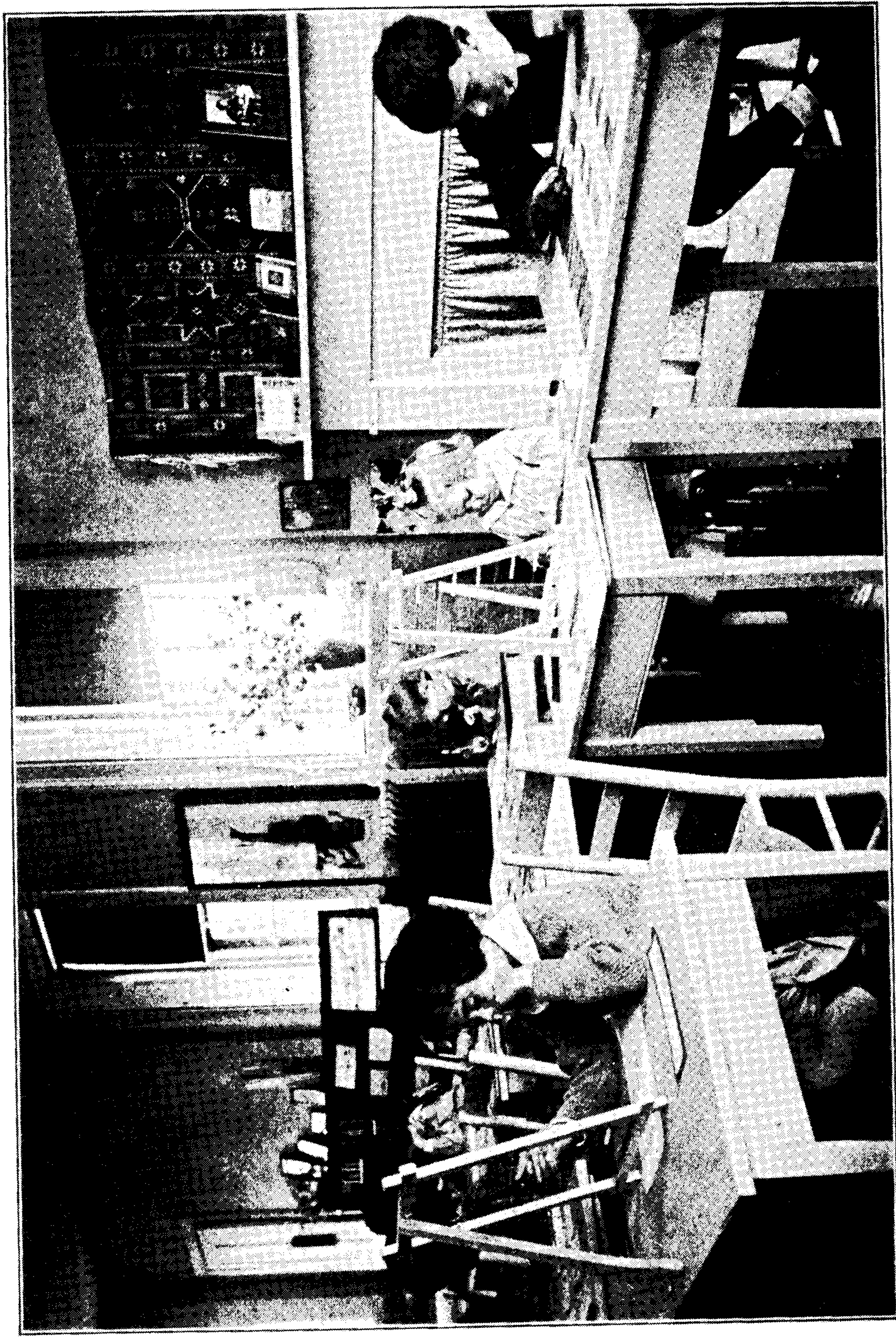

The two little girls are working out problems in seven figures. (The Washington Montessori School, Washington, D. C.)

SUBTRACTION

The counting-frame lends itself equally well to problems in subtraction. Let us take, for example, the following:

$$\begin{array}{r} 8947 - \\ 6735 \\ \hline = \end{array}$$

We place the beads representing the first number; then from them we take the beads representing the second number. The beads remaining indicate the difference between the two numbers; and this is written: 2212.

Then comes the more complicated problem where it is necessary to borrow from a higher denomination. When the beads of one wire are exhausted, we move over the entire ten and take to represent them one bead from the lower wire; then we continue the subtraction. For example:

$$\begin{array}{r} 8954 - \\ 7593 \\ \hline = \end{array}$$

We move the beads representing the first number; then we take 3 beads from the units. Now we begin to subtract the tens. We wish to take away 9 beads; but when we have moved five the wire is empty, and there are still four more to be moved. We take away one bead from the hundreds-wire and replace the entire ten on the tens-wire; and then we continue to move beads on the tens-wire until we have taken a total of nine — that is, we now move the other four. On the hundreds-wire there remain but 8 beads, and from them we take the 5, etc. Our final remainder is 1361.

THIS PAGE IS LOCKED TO FREE MEMBERS

Purchase full membership to immediately unlock this page



HISTORY

Tens of thousands of important historical sources, many previously unobtainable, are now available for the first time with a Forgotten Books Full Membership.

Unlimited Access
\$8.99/month

Continue

*Fair usage policy applies

$$742 = \begin{cases} 2 \text{ units} \\ 4 \text{ tens} \\ 7 \text{ hundreds} \end{cases} \qquad 356 = \begin{cases} 6 \text{ units} \\ 5 \text{ tens} \\ 3 \text{ hundreds} \end{cases}$$

Each of the first numbers is combined with the three figures of the other number in the following manner:

$$\begin{array}{l} \text{u. } 6 \\ \text{t. } 5 \\ \text{h. } 3 \end{array} \left. \vphantom{\begin{array}{l} \text{u. } 6 \\ \text{t. } 5 \\ \text{h. } 3 \end{array}} \right\} \times \text{u. } 2 = \begin{cases} 12 \text{ units} \\ 10 \text{ tens} \\ 6 \text{ hundreds} \end{cases} \qquad \begin{array}{l} \text{u. } 6 \\ \text{t. } 5 \\ \text{h. } 3 \end{array} \left. \vphantom{\begin{array}{l} \text{u. } 6 \\ \text{t. } 5 \\ \text{h. } 3 \end{array}} \right\} \times \text{t. } 4 = \begin{cases} 24 \text{ tens} \\ 20 \text{ hundreds} \\ 12 \text{ thousands} \end{cases}$$

$$\begin{array}{l} \text{u. } 6 \\ \text{t. } 5 \\ \text{h. } 3 \end{array} \left. \vphantom{\begin{array}{l} \text{u. } 6 \\ \text{t. } 5 \\ \text{h. } 3 \end{array}} \right\} \times \text{h. } 7 = \begin{cases} 42 \text{ hundreds} \\ 35 \text{ thousands} \\ 21 \text{ tens of thousands} \end{cases}$$

When this analysis is written down, the work on the counting-frames begins. Here the operations are performed in the following manner: 2×6 units necessitate the bringing forward of the ten beads on the first wire. However, even those do not suffice. So they are slid back and one bead on the second wire is brought forward, to represent the ten replaced, and on the first wire two beads are brought forward (12).

Next we take 2×5 tens. There is already one bead on the tens-wire and to this should be added ten more, but instead we bring forward one bead on the hundreds-wire. At this point in the operation the beads are distributed on the wires in this manner:

2
1
1

Now comes 2×3 hundreds, and six beads on the corresponding wire are brought forward. When the multiplication by the units of the multiplier is finished, the beads on the frame are in the following order:

2
1
7

We pass now to the tens: $4 \times 6 = 24$ tens. We must therefore bring forward four beads on the tens-wire and two on the hundreds-wire:

2
5
9

$4 \times 5 = 20$ hundreds, therefore two thousands:

2
5
9
2

4×3 thousands $= 12$ thousands; so we bring forward two beads on the thousands-wire and one on the ten-thousands-wire:

2
5
9
4
1

Now we take the hundreds: 7×6 hundreds are 42 hundreds; therefore we slide four beads on the thousands-wire and two on the hundreds-wire. But there already were nine beads on this wire, so only one remains and the other ten give us instead another bead on the thousands-wire:

2
5

1
9
1

5×7 thousands = 35 thousands, which is the same as five thousands and three ten-thousands. Three beads on the fifth wire and five on the fourth are brought forward; but on the fourth wire there already were nine beads, so we leave only four, exchanging the other ten for one bead on the fifth wire:

2
5
1
4
5

Finally 7×3 ten-thousands = 21 ten-thousands. One bead is brought forward on the fifth wire and two on the hundred-thousands-wire.

At the end of the operation the beads will be distributed as follows:

2	beads	on	the	first	wire	(units)
5	“	“	“	second	“	(tens)
1	“	“	“	third	“	(hundreds)
4	“	“	“	fourth	“	(thousands)
6	“	“	“	fifth	“	(tens of thousands)
2	“	“	“	sixth	“	(hundreds of thousands)

This distribution translated into figures gives the following number: 264,152. This may be written as a result right after the factors without the partial products: that is, $742 \times 356 = 264,152$.

Although this discription may sound very complicated, the exercise on the counting-frame is an easy and most in-

THIS PAGE IS LOCKED TO FREE MEMBERS

Purchase full membership to immediately unlock this page

Know Your Bible

Forgotten Books' Full Membership provides unlimited access to more than 28,000 volumes of Christian literature for \$8.99/month

**HOLY
BIBLE**

Continue

*Fair use policy applies

higher value for those of lower value when the ten beads of one wire, as a mechanical result of the structure of the frame, are all used. As multiplication is ordinarily written, such substitutions cannot be made; but the partial products must be written down in order, placed in column according to their value, and finally added. This is a much longer piece of work, because the act of writing a figure is more complicated than that of moving a bead which slides easily on the metal wire. Again, it is not so clear as the work with the beads, once the child is accustomed to handling the frame and no longer has any doubt as to the position of the different values, and when it has become a sort of routine to substitute one bead of the lower wire for the ten beads of the upper wire which have been exhausted. Furthermore, it is much easier to add new products without the possibility of making a mistake. Let us go back to the point in the operation where the beads on the frame read thus:

2
5
1
9
1

and it was necessary to add 35 thousands — five beads to the thousands-wire and three beads to the ten-thousands-wire. The three beads on the fifth wire can be brought forward without any thought as to what will happen on the wire above when the five are added to the nine. Indeed, what takes place there does not make any difference, for it is not necessary that the operation on the higher wire precede that on the lower wire.

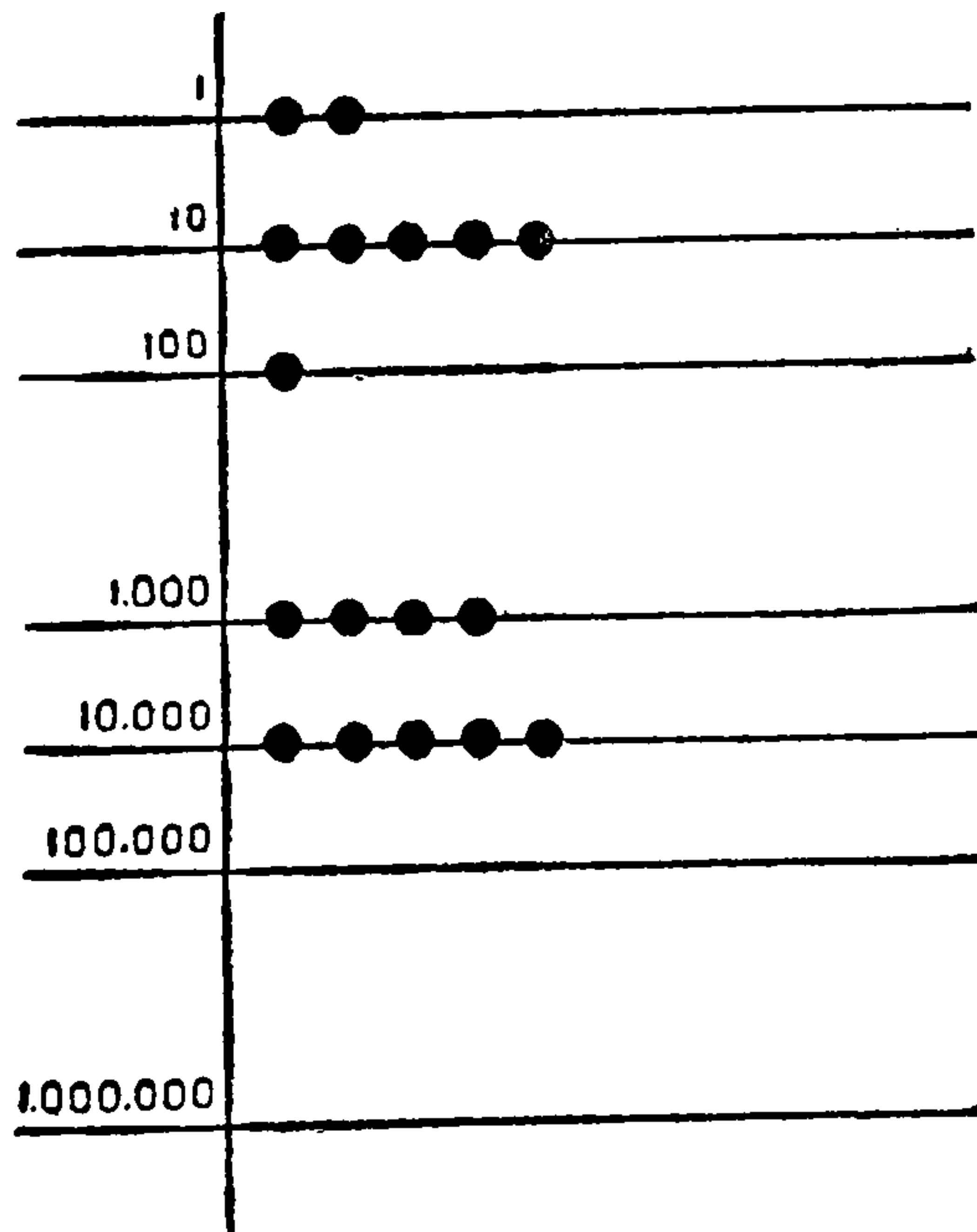

Fig. 2. The disposition of the beads for the number 54,152; after adding 5 thousands to the number 49,152.

In adding the five beads to the nine beads only four remain on the fourth wire, since the other ten are substituted by a bead on the lower wire; this bead may be brought forward even after the three for the ten-thousands have been placed.

By the use of the frame the child acquires remarkable dexterity and facility in calculating, and this makes his work in multiplication much more rapid. Often one child, working out an example on paper, has finished only the first partial multiplication when another child, working at the frame, has completed the problem and knows the final product. It is interesting even among adults to watch two compete in the same problem, one at the frame and the other using the ordinary method on paper.

It is very interesting, also, not to work out on the frame the individual products in the sequence indicated in analyzing the factors, but to work them out by chance. In-

deed, it does not matter whether the beads are moved in the order of their alignment or at random. The beads on the ten-thousands-wire may be moved first, then the hundreds, the units, and finally the thousands.

These exercises, which give such a deep understanding of the operations of arithmetic, would be impossible with the abstract operation which is performed only by means of figures. And it is evident that the exercises can be amplified to any extent as a pleasing game.

MULTIPLYING ON RULED PAPER

Take, for example, 8640×2531 . We write the figures of the multiplicand one under the other but in their relative positions; this also can be written by filling in the vacant spaces with zeros.

In this way we repeat the multiplicand as many times as there are figures in the multiplier; but instead of writing beside these figures the words units, tens, etc., we indicate this with zeros, which, for the sake of clearness, we fill in till they resemble large dots.

The child already knows, from his previous exercises, that zero indicates the position of a figure and that multiplying by ten changes this position. Therefore zeros in the multiplier would cause a corresponding change of position in the figures of the multiplicand.

The accompanying figure shows clearly what it is not so easy to explain in words.

We are now ready for the usual procedure of multiplication. A child of seven years reaches this stage very easily after having done our preliminary exercises, and then it does not matter to him how many figures he has to use. Indeed, he is very fond of working with numbers of unheard of figures, as is shown in the following

THIS PAGE IS LOCKED TO FREE MEMBERS

Purchase full membership to immediately unlock this page



HISTORY

Tens of thousands of important historical sources, many previously unobtainable, are now available for the first time with a Forgotten Books Full Membership.

Unlimited Access
\$8.99/month

Continue

*Fair usage policy applies

without analysis of factors and without help from the frames but by the method commonly used. This may be seen by the way in which the example is written out and then done by the child.

LONG DIVISION

Not only is it possible to perform long division with our bead material, but the work is so delightful that it becomes an arithmetical pastime especially adapted to the child's home activities. Using the beads clarifies the different steps of the operation, creating almost a *rational arithmetic* which supersedes the common empirical methods, that reduce the mechanism of abstract operations to a simple *routine*. For this reason, these pastimes prepare the way for the rational processes of mathematics which the child meets in the higher grades.

The bead frame will no longer suffice here. We need the square arithmetic board used for the first partial multiplications and for short division. However, we require several such boards and an adequate provision of beads. The work is too complicated to be described clearly, but in practise it is easy and most interesting.

It is sufficient here to suggest the method of procedure with the material. The units, tens, hundreds, etc., are expressed by different-colored beads: *units*, white; *tens*, green; *hundreds*, red. Then there are racks of different colors: *white* for the simple units, tens, and hundreds; *gray* for the thousands; *black* for the millions. There also are boxes, which on the outside are white, gray, or black, and on the inside white, green, or red. And for each box there is a corresponding rack containing ten tubes with ten beads in each.

Suppose we must divide 87,632 by 64. Five of the

boxes are put in a row, arranged from left to right according to the value of their color, as follows: two gray boxes — one green inside and the other white — and three white boxes with the inside respectively red, green, and white. In the first box to the left we put 8 green beads; in the second box 7 white beads; in the third, 6 red beads; in the fourth 3 green beads; and in the fifth box 2 white beads. Back of each box is one of the racks with ten tubes filled with beads of corresponding colors. These beads — ten in each tube — are used in exchanging the units of a higher denomination for those of a lower.

There are two arithmetic boards, one next to the other, placed below the row of boxes. In the one to the left, the little cardboard with the figure 6 is inserted in the slot we have described, and in the other to the right the figure 4.

Now to divide 87,632 by 64, place the first two boxes at the left (containing 8 and 7 beads respectively) above the two arithmetic boards. On the first board the eight beads are arranged in rows of six, as in the more simple division. On the second board the seven beads are arranged in rows of four, corresponding to the number indicated by the red figure. The two quotients must be reduced with reference to the quotient in the first arithmetic board. All the other is considered as a remainder. The quotient in this case is 1 and the remainders are 2 on the first board and 3 on the second.

When this is finished, the boxes are moved up one place and then the first box is out of the game, its place having been taken by the second box; so the gray-green box is no longer above the first board but the gray-white one instead, and above the second board we must place the box with the red beads.



The child here is solving a problem in long division. (*Montessori School, Barcelona, Spain.*)

THIS PAGE IS LOCKED TO FREE MEMBERS

Purchase full membership to immediately unlock this page

Know Your Bible

Forgotten Books' Full Membership provides unlimited access to more than 28,000 volumes of Christian literature for \$8.99/month

**HOLY
BIBLE**

Continue

*Fair use policy applies

Now the beads must be adjusted. The two beads that are left over on the card marked with the number 6 are green but the box above this card is the gray-white one. We must therefore change the green beads into white beads, taking for each one of them a tube of ten white beads. The white beads which were left over on the other card must be brought to the card above which the white box is now placed. We have only to arrange the white beads now in rows of six while the other box of red beads is emptied on to the second board in rows of four, as in simple division.

With the material arranged in this way according to color, we proceed to the reduction, which is done by exchanging one bead of a higher denomination for ten of a lower. Thus, for example, in the present case we have twenty-three white beads distributed on the first board in rows of six, which gives a quotient of three and a remainder of five. On the second board there are six red beads distributed in rows of four, giving a quotient of one with a remainder of two. Now the work of reduction begins. This consists in taking one by one the beads from the board to the left — in this case the white — and exchanging them for ten red beads, which in turn are placed in rows of four on the other board until the quotients on the two cards are alike. What is left over is the remainder. In this case it is necessary to change only the one white bead so as to have the other quotient reach three with a remainder of four.

The same process is continued until all the boxes are used.

The final remainder is the one to be written down with the quotient.

The exercise requires great patience and exactness, but

it is most interesting and might be called an excellent game of solitaire for children for home use. There is no intellectual fatigue but much movement and much intense attention. The quotients and remainders may be written on a prepared sheet of paper, so as to be verified by the teacher.

When the child has performed many of these exercises he comes spontaneously to try to foresee the result of an operation without having to make the material exchange and arrangement of the beads; hence to shorten the mechanical process. When at length he can "see" the situation at a glance, he will be able to do the most difficult division by the ordinary processes without experiencing any fatigue, or without having been obliged to endure tiring progressive lessons and humiliating corrections. Not only will he have learned how to perform long divisions but he will have become a master of their mechanism. He will realize each step, in ways that the children of ordinary secondary schools possibly never will be able to understand, when through the usual methods of rational mathematics they approach the incomprehensible operations which they have performed for several years without considering the reasons for them.

EXERCISES WITH NUMBERS

MULTIPLES, PRIME NUMBERS, FACTORING

When the child, by the aid of all this material, has had a chance to grasp the fundamental ideas relating to the four operations and has passed on to the execution of them in the abstract, he is ready to continue on the numerical processes which will lead to a more profound study preparatory to the more complex problems that await him in the secondary schools.

These studies are, however, a means of helping him to remember the things he already knows and to enlarge upon them. They come to him as a pastime, as an agreeable manner of thinking over either in school or at home the ideas which he already has gained.

One of the first exercises is that of continuing the multiplication of each number by the series of 1 to 10 which was begun by the exercises on the multiplication tables. This should be done in the abstract: that is, without recourse to the material. Let us, however, set some limit — we will stop when each product has reached 100. In order that these series of exercises may each be in one column the first exercises will stop with 50 and another can be used for the numbers from 51 to 100.

The two following tables (A and B) are the result. These are prepared in this manner in our material so that the child may compare his work with them.

THIS PAGE IS LOCKED TO FREE MEMBERS

Purchase full membership to immediately unlock this page

HISTORY

Tens of thousands of important historical sources, many previously unobtainable, are now available for the first time with a Forgotten Books Full Membership.

Unlimited Access
\$8.99/month

Continue

*Fair usage policy applies



TABLE C

1	51
2	52
3	53
4	54
5	55
6	56
7	57
8	58
9	59
10	60
11	61
12	62
13	63
14	64
15	65
16	66
17	67
18	68
19	69
20	70
21	71
22	72
23	73
24	74
25	75
26	76
27	77
28	78
29	79
30	80
31	81
32	82
33	83
34	84
35	85
36	86
37	87
38	88
39	89
40	90
41	91
42	92
43	93
44	94
45	95
46	96
47	97
48	98
49	99
50	100

TABLE D

1		53	
2		54	$= 2 \times 27 = 3 \times 18 = 6 \times 9 =$
3			9×6
4	$= 2 \times 2$	55	$= 5 \times 11$
5		56	$= 2 \times 28 = 4 \times 14 = 7 \times 8 =$
6	$= 2 \times 3 = 3 \times 2$		8×7
7		57	$= 3 \times 19$
8	$= 2 \times 4 = 4 \times 2$	60	$= 2 \times 29$
9	$= 3 \times 3$		
10	$= 5 \times 2$		$= 2 \times 30 = 3 \times 20 = 4 \times 15 =$
11			$5 \times 12 = 6 \times 10 = 15 \times 4$
12	$= 2 \times 6 = 3 \times 4 = 4 \times 3 = 6 \times 2$	61	
13		62	$= 2 \times 31$
14	$= 2 \times 7 = 7 \times 2$	63	$= 3 \times 21 = 7 \times 9 = 9 \times 7$
15	$= 3 \times 5 = 5 \times 3$	64	$= 2 \times 32 = 4 \times 16 = 8 \times 8$
16	$= 4 \times 4 = 8 \times 2$	65	$= 5 \times 13$
17		66	$= 2 \times 33 = 3 \times 22 = 6 \times 11$
18	$= 2 \times 9 = 3 \times 6 = 6 \times 3 = 9 \times 2$	67	
19		68	$= 2 \times 34 = 4 \times 17$
20	$= 2 \times 10 = 4 \times 5 = 5 \times 4 =$	69	$= 3 \times 23$
	10×2	70	$= 2 \times 35 = 5 \times 14 = 7 \times 10 =$
21	$= 7 \times 3 = 3 \times 7$		10×7
22	$= 2 \times 11$	71	
23		72	$= 2 \times 36 = 3 \times 24 = 4 \times 18 =$
24	$= 2 \times 12 = 3 \times 8 = 4 \times 6 =$		$6 \times 12 = 8 \times 9 = 9 \times 8$
	$6 \times 4 = 8 \times 3$	73	
25	$= 5 \times 5$	74	$= 2 \times 37$
28	$= 2 \times 13$	75	$= 3 \times 25 = 5 \times 15$
	$9 = 9 \times 3$	76	$= 2 \times 38 = 4 \times 19$
	$\times 14 = 4 \times 7 = 7 \times 4$	77	$= 7 \times 11$
		78	$= 2 \times 39 = 3 \times 26 = 6 \times 13$
	$= 2 \times 15 = 3 \times 10 = 5 \times 6 =$	79	
	$6 \times 5 = 10 \times 3$	80	$= 2 \times 40 = 4 \times 20 = 5 \times 16 =$
31			$8 \times 10 = 10 \times 8$
32	$= 2 \times 16 = 4 \times 8 = 8 \times 4$	81	$= 3 \times 27 = 9 \times 9$
33	$= 3 \times 11$	82	$= 2 \times 41$
34	$= 1$	83	
35	$= 7 = 7 \times 5$	84	$= 2 \times 42 = 3 \times 28 = 4 \times 21 =$
36	$= 18 = 3 \times 12 = 4 \times 9 =$		$6 \times 14 = 7 \times 12$
	$6 \times 6 = 9 \times 4$	85	$= 5 \times 17$
37		86	$= 2 \times 43$
38	$= 2 \times 19$	87	$= 3 \times 29$
39	$= 13$	88	$= 2 \times 44 = 4 \times 22 = 8 \times 11$
40	$= 2 = 4 \times 10 = 5 \times 8 =$	89	
	$8 \times 5 = 10 \times 4$	90	$= 2 \times 45 = 3 \times 30 = 5 \times 18 =$
41			$6 \times 15 = 9 \times 10 = 10 \times 9$
42	$= 2 \times 21 = 3 \times 14 = 6 \times 7 =$	91	$= 7 \times 13$
	7×6	92	$= 2 \times 46 = 4 \times 23$
43		93	$= 3 \times 31$
48	$= 2 \times 22 = 4 \times 11$	94	$= 2 \times 47$
	$= 3 \times 15 = 5 \times 9 = 9 \times 5$	95	$= 5 \times 19$
	\times	96	$= 2 \times 48 = 3 \times 32 = 4 \times 24 =$
			$6 \times 16 = 8 \times 12$
	$= 2 \times 24 = 3 \times 16 = 4 \times 12 =$	97	
	$6 \times 8 = 8 \times 6$	98	$= 2 \times 49 = 7 \times 14$
49	$= 7 \times 7$		$= 3 \times 33 = 9 \times 11$
50	$= 2 \times 25 = 5 \times 10 = 10 \times 5$		$2 \times 0 = 4 \times 25 = 5 \times 20 =$
51	$= 16$		1×10
52	$= 4 \times 13$		

THIS PAGE IS LOCKED TO FREE MEMBERS

Purchase full membership to immediately unlock this page

Know Your Bible

Forgotten Books' Full Membership provides unlimited access to more than 28,000 volumes of Christian literature for \$8.99/month

HOLY BIBLE

Continue

*Fair use policy applies

$$= 6 \times 3 = \begin{array}{cccccc} \bullet & & \bullet & & \bullet & & \bullet & & \bullet & & \bullet \\ \bullet & & \bullet & & \bullet & & \bullet & & \bullet & & \bullet \end{array}$$

$$= 3 \times 6 = \begin{array}{ccc} \bullet & \bullet & \bullet \\ \bullet & \bullet & \bullet \\ \bullet & \bullet & \bullet \end{array} \quad \begin{array}{ccc} \bullet & \bullet & \bullet \\ \bullet & \bullet & \bullet \\ \bullet & \bullet & \bullet \end{array} \quad \begin{array}{ccc} \bullet & \bullet & \bullet \\ \bullet & \bullet & \bullet \\ \bullet & \bullet & \bullet \end{array}$$

The child will try in every way to make other combinations and he will try also to divide the prime numbers into factors.

This intelligent and pleasing game makes clear to the child the "divisibility" of numbers. The work that he does in getting these factors by multiplication is really a way of dividing the numbers. For example, he has divided 18 into 2 equal groups, 9 equal groups, 6 equal groups, and 3 equal groups. Previously he has divided 6 into 2 equal groups and then into 3 equal groups. Therefore when it is a question of multiplying the two factors there is no difference in the result whether he multiplies 2 by 3 or 3 by 2; for the inverted order of the factors does not change the product. But in division the object is to arrange the number in equal parts and any modification in this equal distribution of objects changes the character of the grouping. Each separate combination is a different way of dividing the number.

The idea of division is made very clear to the child's mind: $6 \div 3 = 2$, means that the 6 can be divided into three groups, each of which has two units or objects; and $6 \div 2 = 3$, means that the 6 also can be divided into but two equal groups, each group made up of three units or objects.

The relations between multiplication and division are very evident since we started with $6 = 3 \times 2$; $6 = 2 \times 3$. This brings out the fact that multiplication may be used to prove division; and it prepares the child to understand the practical steps taken in division. Then some day when he has to do an example in long division, he will

find no difficulty with the mental calculation required to determine whether the dividend, or a part of it, is divisible by the divisor. This is not the usual preparation for division, though memorizing the multiplication table is indeed used as a preparation for multiplication.

From the above exercises (Table D) others might be derived involving further analysis of the same numbers. For example, one of the possible factor groups for the number 40 is 2×20 . But $20 = 2 \times 10$; and $10 = 2 \times 5$. Bringing together the smaller figures into which the larger numbers have been broken, we get $40 = 2 \times 2 \times 2 \times 5$; in other words $40 = 2^3 \times 5$.

This is the result for 60:

$$60 = 2 \times 30 = 2 \times 2 \times 15 = 2 \times 2 \times 3 \times 5 = \\ 2^2 \times 3 \times 5$$

For these two numbers we get accordingly the prime factors: $2^3 \times 5$; and $2^2 \times 3 \times 5$. What then have the two larger numbers, 40 and 60 in common? The 2^2 is included in the 2^3 ; the series therefore may be written: $2^2 \times 2 \times 5$; and $2^2 \times 3 \times 5$. The common element (the greatest common divisor) is $2^2 \times 5 = 20$. The proof consists in dividing 60 and 40 by 20, something which will not be possible for any number higher than 20.

We have test sheets where the numbers from 1 to 100 are arranged in rows of 10, forming a square. Here the child's exercise consists in underlining, in different squares, the multiples of 2, 3, 4, 5, 6, 7, 8, 9, 10. The numbers so underlined stand out like a design in such a way that the child easily can study and compare the tables. For instance, in the square where he underlines the multiples of 2 all the even numbers in the vertical columns are marked; in the multiple of 4 we have the same linear

TABLE E

1	2	3	4	5	6	7	8	9	10	1	2	3	4	5	6	7	8	9	10
11	12	13	14	15	16	17	18	19	20	11	12	13	14	15	16	17	18	19	20
21	22	23	24	25	26	27	28	29	30	21	22	23	24	25	26	27	28	29	30
31	32	33	34	35	36	37	38	39	40	31	32	33	34	35	36	37	38	39	40
41	42	43	44	45	46	47	48	49	50	41	42	43	44	45	46	47	48	49	50
51	52	53	54	55	56	57	58	59	60	51	52	53	54	55	56	57	58	59	60
61	62	63	64	65	66	67	68	69	70	61	62	63	64	65	66	67	68	69	70
71	72	73	74	75	76	77	78	79	80	71	72	73	74	75	76	77	78	79	80
81	82	83	84	85	86	87	88	89	90	81	82	83	84	85	86	87	88	89	90
91	92	93	94	95	96	97	98	99	100	91	92	93	94	95	96	97	98	99	100

1	2	3	4	5	6	7	8	9	10	1	2	3	4	5	6	7	8	9	10
11	12	13	14	15	16	17	18	19	20	11	12	13	14	15	16	17	18	19	20
21	22	23	24	25	26	27	28	29	30	21	22	23	24	25	26	27	28	29	30
31	32	33	34	35	36	37	38	39	40	31	32	33	34	35	36	37	38	39	40
41	42	43	44	45	46	47	48	49	50	41	42	43	44	45	46	47	48	49	50
51	52	53	54	55	56	57	58	59	60	51	52	53	54	55	56	57	58	59	60
61	62	63	64	65	66	67	68	69	70	61	62	63	64	65	66	67	68	69	70
71	72	73	74	75	76	77	78	79	80	71	72	73	74	75	76	77	78	79	80
81	82	83	84	85	86	87	88	89	90	81	82	83	84	85	86	87	88	89	90
91	92	93	94	95	96	97	98	99	100	91	92	93	94	95	96	97	98	99	100

1	2	3	4	5	6	7	8	9	10	1	2	3	4	5	6	7	8	9	10
11	12	13	14	15	16	17	18	19	20	11	12	13	14	15	16	17	18	19	20
21	22	23	24	25	26	27	28	29	30	21	22	23	24	25	26	27	28	29	30
31	32	33	34	35	36	37	38	39	40	31	32	33	34	35	36	37	38	39	40
41	42	43	44	45	46	47	48	49	50	41	42	43	44	45	46	47	48	49	50
51	52	53	54	55	56	57	58	59	60	51	52	53	54	55	56	57	58	59	60
61	62	63	64	65	66	67	68	69	70	61	62	63	64	65	66	67	68	69	70
71	72	73	74	75	76	77	78	79	80	71	72	73	74	75	76	77	78	79	80
81	82	83	84	85	86	87	88	89	90	81	82	83	84	85	86	87	88	89	90
91	92	93	94	95	96	97	98	99	100	91	92	93	94	95	96	97	98	99	100

THIS PAGE IS LOCKED TO FREE MEMBERS

Purchase full membership to immediately unlock this page



HISTORY

Tens of thousands of important historical sources, many previously unobtainable, are now available for the first time with a Forgotten Books Full Membership.

Unlimited Access
\$8.99/month

Continue

*Fair usage policy applies

VI

SQUARE AND CUBE OF NUMBERS

Let us take two of the two-bead bars (green) which were used in counting in the first bead exercises. Here, however, these form part of another series of beads. Along with these two bars there is a small chain: ●● — ●●. By joining two like bars, the chains represent 2×2 . There is another combination of these same objects — the two bars are joined together not in a chain but in the form of a square: ●●
●●

They represent the same thing: that is to say, as numbers they are 2×2 ; but they differ in position — one has the form of a line, the other of a square. It can be seen from this that if as many bars as there are beads on a bar are placed side by side they form a square.

In the series in fact we offer squares of 3×3 pink beads; 4×4 yellow beads; 5×5 pale blue beads; 6×6 gray beads; 7×7 white beads; 8×8 lavender beads; 9×9 dark blue beads; and 10×10 orange beads; thus reproducing the same colors as were used at the beginning in counting.

For every number there are as many bars as there are beads for the number, 3 bars for the 3, 4 for the 4, etc.; in addition there is a chain consisting of an equal number of bars, 3×3 ; 4×4 ; and, as we have seen, there is a square containing another equal quantity.

The child not only can count the beads of the chains

and squares, but he can reproduce them by placing the corresponding single bars either in a horizontal line or laying them side by side in the shape of a square. The number repeated as many times as the unit it contains is really the multiplication of the number by itself.

For example, taking the small square of four the child can count four beads on each side; multiplying 4 by 4 we have the number of beads in the square, 16. Multiplying one side by itself (squaring one side) we have the area of the little square.

This can be continued for 5, 8, 9, etc. The square of 10 has ten beads on each side. Multiplying 10 by 10, in other words, "squaring" one side we get the entire number of beads forming the area of the square: 100.

However, it is not the form alone which gives these results; for if the ten bars which formed the square are placed end to end in a horizontal line, we get the "hundred chain." This can be done with each square; the chain 5×5 , like the square 5×5 , contains the same number of beads, 25. We teach the child to write the numbers with symbol for the square: $5^2 = 25$; $7^2 = 49$; $10^2 = 100$, etc.

Our material here is manufactured with reference to the numbers 2, 3, 4, 5, 6, 7, 8, 9, 10. It is "offered" to the child, beginning with the smaller numbers. Given the material and freedom, the idea will come of itself and the child will "work" it into his consciousness on them.

In this same period we take up also the cubes of the numbers, and there is a similar material for this: that is, the chain of the cube of the number is made up of chains of the square of that number joined by several links which permit of its being folded. There are as many squares for a number as there are units in that number — four

squares for number 4, six squares for 6, ten squares for 10 — and a cube of the beads is formed by placing the necessary number of squares one on top of the other.

Let us consider the cube of four. There is a chain formed by four chains each representing the square of four. They are joined by small links so that the chain

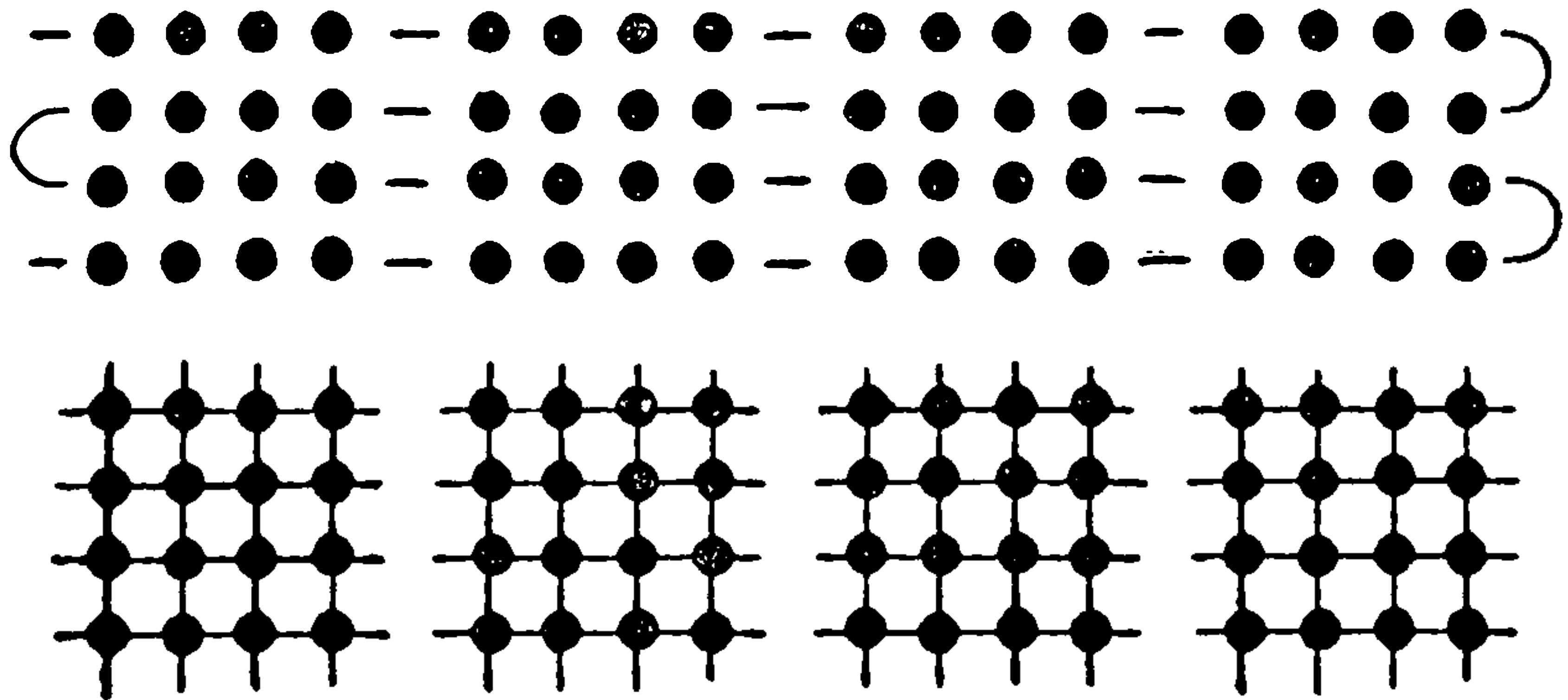

can be rolled up lengthwise. The chain of the cube, when thus rolled, gives four squares similar to the separate squares, which, when drawn out again, form a straight line.

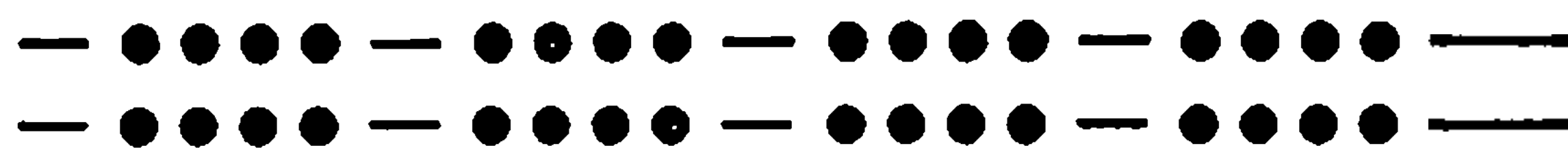

Fig. 5.—This shows only part of the entire chain for 4^3 .

The quantity is always the same: four times the square of four. $4 \times 4 \times 4 = 4^2 \times 4 = 4^3$.

The cube of four comes with the material; but it can be reproduced by placing four loose squares one on top of the other. Looking at this cube we see that it has all its edges of four. Multiplying the area of a square by the number of units contained in the side gives the volume of the cube: $4^2 \times 4$.

In this way the child receives his first intuitions of the processes necessary for finding a surface and volume.

With this material we should not try to teach a great

THIS PAGE IS LOCKED TO FREE MEMBERS

Purchase full membership to immediately unlock this page

Know Your Bible

Forgotten Books' Full Membership provides unlimited access to more than 28,000 volumes of Christian literature for \$8.99/month

HOLY BIBLE

Continue

*Fair use policy applies

of the relations of quantity. By this time these cubes are no longer recognized superficially through sensorial impressions, but their minutest details are known to the child through the progressively intelligent work which they have occasioned.

PART IV
GEOMETRY

THIS PAGE IS LOCKED TO FREE MEMBERS

Purchase full membership to immediately unlock this page



HISTORY

Tens of thousands of important historical sources, many previously unobtainable, are now available for the first time with a Forgotten Books Full Membership.

Unlimited Access
\$8.99/month

Continue

*Fair usage policy applies

PLANE GEOMETRY

The geometric insets used for sensorial exercises in the "Children's House" made it possible for the child to become familiar with many figures of plane geometry: the square, rectangle, triangle, polygon, circle, ellipse, etc. By means of the third series of corresponding cards, where the figures are merely outlined, he formed the habit of recognizing a geometric figure represented merely by a line. Furthermore, he has used a series of iron insets reproducing some of the geometric figures which he previously had learned through the use of wooden geometric insets. He used these iron insets to draw the outline of a figure, which he then filled in with parallel lines by means of colored pencils (an exercise in handling the instruments of writing).

The geometric material here presented to the elementary classes supplements that used in the "Children's House." It is similar to the iron insets; but in this material each frame is fastened to an iron foundation of exactly the same size as the frame. Since each piece is complete in itself, no rack is needed to hold them.

The frame of the inset is green, the foundation is white, and the inset itself — the movable portion — is red. When the inset is in the frame, the red surface and the green frame are in the same plane.

This material further differs from the other in that each

inset is composed not of a single piece, as in the first material, but of many pieces which, when put together on the white foundation, exactly reproduce the geometric figure there designated.

The use to which these modified insets may be put is most varied. The main purpose is to facilitate the child's auto-education through exercises in geometry and often through the solution of real problems. The fact of being able actually to "handle geometric figures," to arrange them in different ways, and to judge of the relations between them, commands the child's absorbed attention. The putting together of the insets, which deal with equivalent figures, reminds one of the "games of patience"—picture puzzles—which have been invented for children but which, while amusing them, have no definite educational aim. Here, however, the child leaves the exercises with "clear concepts" and not merely with general "notions" of the principles of geometry, a thing which is very hard to accomplish by the methods common to the older schools. The difference between like figures, similar figures, and equivalent figures, the possibility of reducing every regular plane figure to an equivalent rectangle, and finally the solution of the theorem of Pythagoras—all these are acquired eagerly and spontaneously by the child. The same may be said about work in fractions, which is made most interesting by the exercises with the circular insets. The real meaning of the word *fraction*, operations in fractions, the reduction of common fractions to decimal fractions—all of this is mastered and becomes perfectly clear in the child's mind.

These are formative conquests and at the same time a dynamic part of the child's intellectual activity. A child who works spontaneously and for a long period of time

with this material not only strengthens his reasoning powers and his character but acquires higher and clearer cognitions, which increase his mental capacity. In his succeeding spontaneous flights into the abstract he will show ability for surprising progress. While a high school child is still wasting his mental effort in trying to understand the relation between geometrical figures, which it seems impossible for him to comprehend, our child in the primary grades is "finding it out for himself" and is so elated by his discovery that he immediately begins the search for other geometrical relations. Our children gallop freely along over a smooth road, urged on by the inner energy of their growing psychic organism, while many other children plod on barefooted and in shackles over stony paths.

Every positive conquest gained through objects with our method of freedom — allowing the child to exercise himself at the time when he is most ready for the exercise and permitting him to complete this exercise — results in spontaneous abstractions. How is it possible to lead a child to perform abstractions if his mind is not sufficiently mature and he is without adequate information? These two points of support are, as it were, the feet of the psychic man who is traveling toward his highest mental activities. We shall always see the repetition of this phenomenon. Every ulterior exercise of inner development, every ulterior cognition, will lead the child to new and ever higher flights into the realm of the abstract. It is well, however, to emphasize this principle: that the mind, in order to fly, must leave from some point of contact, just as the aeroplane starts from its hangar, and that it must have reached a certain degree of maturity, as is the case with the small bird when it tries its wings

THIS PAGE IS LOCKED TO FREE MEMBERS

Purchase full membership to immediately unlock this page

Know Your Bible

Forgotten Books' Full Membership provides unlimited access to more than 28,000 volumes of Christian literature for \$8.99/month

HOLY BIBLE

Continue

*Fair use policy applies

systematic auto-exercises of preparation. After this it suffices merely to grant freedom to the child's genius in order that it may take its own flight.

I need not repeat that even in the period of replenishing, freedom is the guide in finding the "particular moment" and the "necessary time"; for I already have spoken insistently and at length concerning this. It is well, however, to reaffirm here even more clearly that a material for development predetermined by experimental research and put into relation with the child (through lessons) accomplishes so complete a work by the psychic reactions which it is capable of stimulating that marvelous phenomena of intellectual development may be obtained. These geometric insets furnish rich materials for the application of this principle and respond wonderfully to the "instinct for work" in the child mind.

The exercises with this material not only are exercises of composition with the pieces of an inset or of the substitution of them into their relative metal plates; they are also exercises in drawing which, because of the labor they require, allow the child to take cognizance of every detail and to meditate upon it.

The designing done with these geometric insets, as will be explained, is of two kinds: geometric and artistic (mechanical and decorative). And the union of the two kinds of drawings gives new ways of applying the material.

The geometric design consists in reproducing the figure outlined by the corresponding insets. In this way the child learns to use the different instruments of drawing — the square, the ruler, the compass, and the protractor. In these exercises he acquires, with the aid of the special portfolio which comes with the material, actual and real cognitions in geometry.

Artistic designs are made by combining the small pieces of the various geometric insets. The resulting figures are then outlined and filled in with colored pencils or water-colors. Such combinations on the part of the child are real esthetic creations. The insets are of such reciprocal proportions that their combination results in an artistic harmony which facilitates the development of the child's esthetic sense. With our insets we were able to reproduce some of the classic decorations found in our masterpieces of art, such as decorations by Giotto.

A combination of geometric design and artistic design is formed by decorating the different parts of the geometric figure — as the center, the sides, the angles, the circumference, etc.; or by elaborating with free-hand details the decorations which have resulted from the combination of the insets. But a far better concept of all this will be gained as we pass on to explain our didactic material.

II

THE DIDACTIC MATERIAL USED FOR GEOMETRY

EQUIVALENT, IDENTICAL AND SIMILAR FIGURES

FIRST SERIES OF INSETS: *Squares and Divided Figures.* This is a series of nine square insets, ten by ten centimeters, each of which has a white foundation of the same size as the inset.

One inset consists of an entire square; the others are made up in the following manner:

A square divided into two equal rectangles	
” ” ” ”	four equal squares.
” ” ” ”	eight equal rectangles
” ” ” ”	sixteen equal squares
” ” ” ”	two equal triangles
” ” ” ”	four equal triangles
” ” ” ”	eight equal triangles
” ” ” ”	sixteen equal triangles

The child can take the square divided into two rectangles and the one divided into two triangles and interchange them: that is, he can build the first square with triangles and the second with rectangles. The two triangles can be superimposed by placing them in contact at the under side where there is no knob, and the same can be done with the rectangles, thus showing their equivalence by placing one on the other. But there also is a certain

THIS PAGE IS LOCKED TO FREE MEMBERS

Purchase full membership to immediately unlock this page



HISTORY

Tens of thousands of important historical sources, many previously unobtainable, are now available for the first time with a Forgotten Books Full Membership.

Unlimited Access
\$8.99/month

Continue

*Fair usage policy applies

square by a medial line and are identical; the two triangles are formed by dividing the original square by a diagonal line, etc. *Similar* figures, on the other hand, are those which have the same form but differ in dimension. For example, the rectangle which is half of the original square and the one which is half of the smaller square — that is, an eighth of the original square — are neither identical nor equivalent but they are *similar* figures. The same may be said of the large square and of the smaller ones which represent a fourth, a sixteenth, etc.

Through these divisions of the square an idea of fractions is gained intuitively. However, this is not the material used for the study of fractions. For this purpose there is another series of insets.

SECOND SERIES OF INSETS: *Fractions.* There are ten metal plates, each of which has a circular opening ten centimeters in diameter. One inset is a complete circle; the other circular insets are divided respectively into 2, 3, 4, 5, 6, 7, 8, 9, and 10 equal parts.

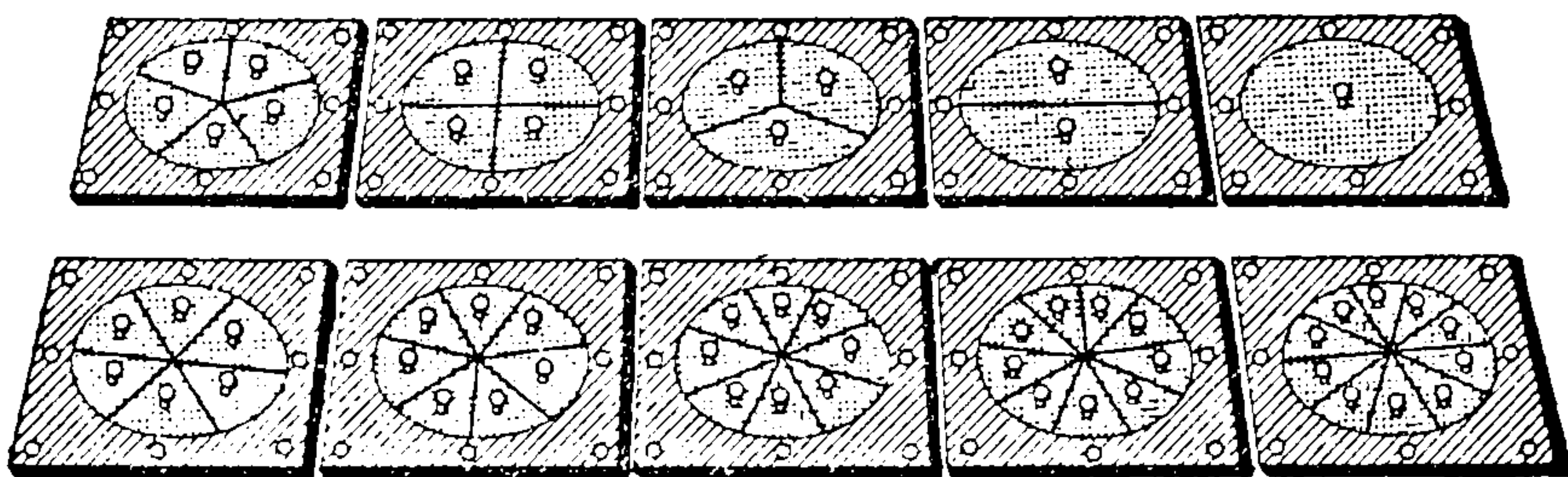

The children learn to measure the angles of each piece, and so to count the degrees. For this work there is a circular piece of white card-board, on which is drawn in black a semicircle with a radius of the same length as that of the circular insets. This semicircle is divided into 18 sectors by radii which extend beyond the circumference on to the background; and these radii are numbered by tens

from 0° to 180° . Each sector is then subdivided into ten parts or degrees.

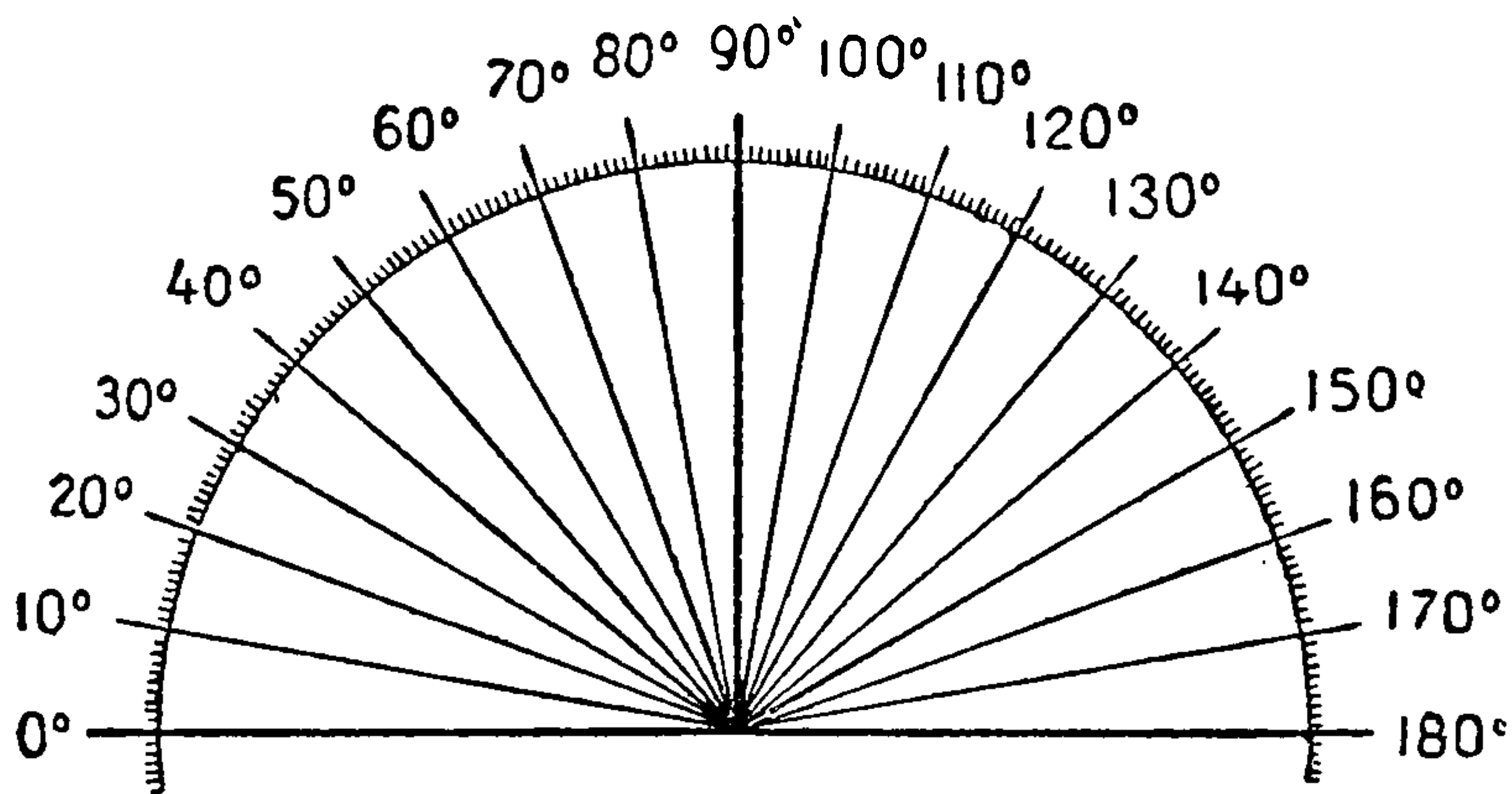

The diameter from 0° to 180° is outlined heavily and extends beyond the circumference, in order to facilitate the adjustment of the angle to be measured and to give a strict exactness of position. This is done also with the radius which marks 90° . The child places a piece of an inset in such a way that the vertex of the angle touches the middle of the diameter and one of its sides rests on the radius marked 0° . At the other end of the arc of the inset he can read the degrees of the angle. After these exercises, the children are able to measure any angle with a common protractor. Furthermore, they learn that a circle measures 360° , half a circle 180° , and a right angle 90° . Once having learned that a circumference measures 360° they can find the number of degrees in any angle; for example, in the angle of an inset representing the seventh of the circle, they know that $360^\circ \div 7 =$ (approximately) 51° . This they can easily verify with their instruments by placing the sector on the graduated circle.

These calculations and measurements are repeated with all the different sectors of this series of insets where the

circle is divided into from two to ten parts. The protractor shows approximately that:

$\frac{1}{3}$	circle	=	120°	and	$360^\circ \div 3 = 120^\circ$
$\frac{1}{4}$	"	=	90°	"	$360^\circ \div 4 = 90^\circ$
$\frac{1}{5}$	"	=	72°	"	$360^\circ \div 5 = 72^\circ$
$\frac{1}{6}$	"	=	60°	"	$360^\circ \div 6 = 60^\circ$
$\frac{1}{7}$	"	=	51°	"	$360^\circ \div 7 = 51^\circ$
$\frac{1}{8}$	"	=	45°	"	$360^\circ \div 8 = 45^\circ$
$\frac{1}{9}$	"	=	40°	"	$360^\circ \div 9 = 40^\circ$
$\frac{1}{10}$	"	=	36°	"	$360^\circ \div 10 = 36^\circ$

In this way the child learns to write fractions:

$$\frac{1}{2} \quad \frac{1}{3} \quad \frac{1}{4} \quad \frac{1}{5} \quad \frac{1}{6} \quad \frac{1}{7} \quad \frac{1}{8} \quad \frac{1}{9} \quad \frac{1}{10}$$

He has concrete impressions of them as well as an intuition of their arithmetical relationships.

The material lends itself to an infinite number of combinations, all of which are real arithmetical exercises in fractions. For example, the child can take from the circle the two half circles and replace them by four sectors of 90° , filling the same circular opening with entirely dif-

THIS PAGE IS LOCKED TO FREE MEMBERS

Purchase full membership to immediately unlock this page

Know Your Bible

Forgotten Books' Full Membership provides unlimited access to more than 28,000 volumes of Christian literature for \$8.99/month

**HOLY
BIBLE**

Continue

*Fair use policy applies

$$\frac{1}{2} + \frac{1}{2} = \frac{2}{2}; \quad \frac{1}{4} + \frac{1}{4} + \frac{1}{4} + \frac{1}{4} = \frac{4}{4}.$$

The two halves make an entire circle, as do the four fourths.

Now let us fill a circle with different pieces: for example, with a half circle and two quarter circles. The

result is $1 = \frac{1}{2} + \frac{2}{4}$. And in the inset itself it is

shown that $\frac{1}{2} = \frac{2}{4}$. If we should wish to fill the circle

with the largest piece ($\frac{1}{2}$) combined with the fewest number of pieces possible, it would be necessary to withdraw the two quarter sectors and replace them by another half circle; result:

$$1 = \frac{1}{2} + \frac{1}{2} = \frac{2}{2} = 1.$$

Let us fill a circle with three $\frac{1}{5}$ sectors and four $\frac{1}{10}$ sectors:

$$1 = \frac{3}{5} + \frac{4}{10}.$$

If the larger pieces are left in and the circle is then filled with the fewest number of pieces possible, it would necessitate replacing the four tenths by two fifths. Result:

$$1 = \frac{3}{5} + \frac{2}{5} = \frac{5}{5} = 1.$$

Let us fill the circle thus: $\frac{5}{10} + \frac{1}{4} + \frac{2}{8} = 1$.

Now try to put in the largest pieces possible by substituting for several small pieces a large piece which is

equal to them. In the space occupied by the five tenths may be placed one half, and in that occupied by the two eighths, one fourth; then the circle is filled thus:

$$1 = \frac{1}{2} + \frac{1}{4} + \frac{1}{4} = \frac{1}{2} + \frac{2}{4}.$$

We can continue to do the same thing, that is to replace the smaller pieces by as large a sector as possible, and the two fourths can be replaced by another half circle. Result:

$$1 = \frac{1}{2} + \frac{1}{2} = \frac{2}{2} = 1.$$

All these substitutions may be expressed in figures thus:

$$\frac{5}{10} + \frac{1}{4} + \frac{2}{8} = \frac{1}{2} + \frac{1}{4} + \frac{1}{4} =$$

$$\frac{1}{2} + \frac{2}{4} = \frac{1}{2} + \frac{1}{2} = \frac{2}{2} = 1.$$

This is one means of initiating a child intuitively into the operations used for the reduction of fractions to their lowest terms.

Improper fractions also interest them very much. They come to these by adding a number of sectors which fill two, three, or four circles. To find the whole numbers which exist under the guise of fractions is a little like putting away in their proper places the circular insets which have been all mixed up. The children manifest a desire to learn the real operations of fractions. With improper fractions they originate most unusual sums, like the following:

$$\frac{\left[8 + \left(\frac{7}{7} + \frac{18}{9} + \frac{24}{2}\right) + 1\right]}{8} =$$

$$\frac{[8 + (1 + 2 + 12) + 1]}{8} =$$

$$\frac{8 + 15 + 1}{8} = \frac{24}{8} = 3.$$

We have a series of commands which may be used as a guide for the child's work. Here are some examples:

- Take $\frac{1}{5}$ of 25 beads
- Take $\frac{1}{4}$ “ 36 counters
- Take $\frac{1}{6}$ “ 24 beans
- Take $\frac{1}{3}$ “ 27 beans
- Take $\frac{1}{10}$ “ 40 beans
- Take $\frac{2}{5}$ “ 60 counters

In this last there are two operations:

$$60 \div 5 = 12; 12 \times 2 = 24; \text{ or } 2 \times 60 = 120;$$

$$120 \div 5 = 24, \text{ etc.}$$

REDUCTION OF COMMON FRACTIONS TO DECIMAL FRACTIONS: The material for this purpose is similar to that of the circular insets, except that the frame is white and is marked into ten equal parts, and each part is then subdivided into ten. In these subdivisions the little line

THIS PAGE IS LOCKED TO FREE MEMBERS

Purchase full membership to immediately unlock this page



HISTORY

Tens of thousands of important historical sources, many previously unobtainable, are now available for the first time with a Forgotten Books Full Membership.

Unlimited Access
\$8.99/month

Continue

*Fair usage policy applies

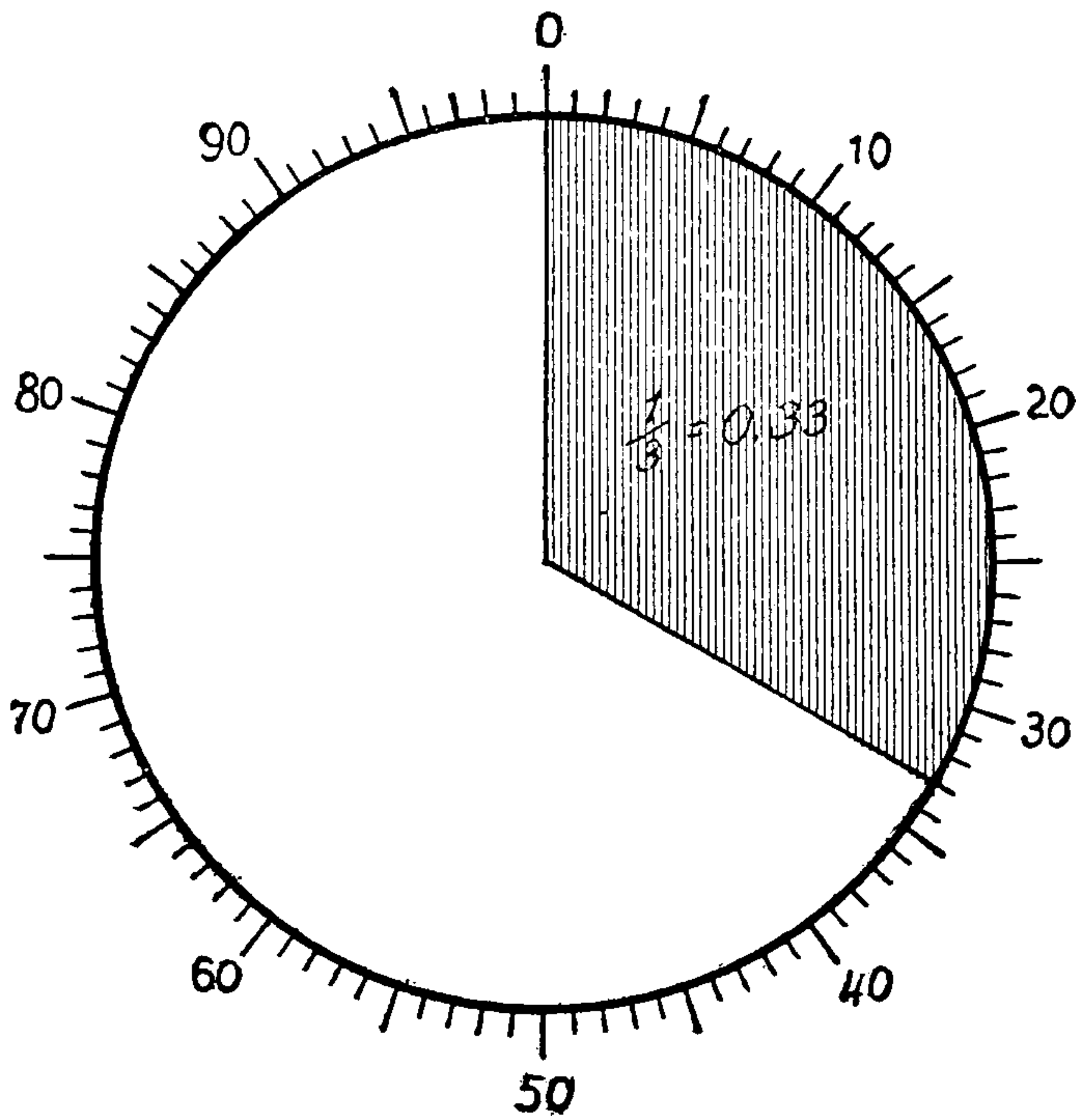
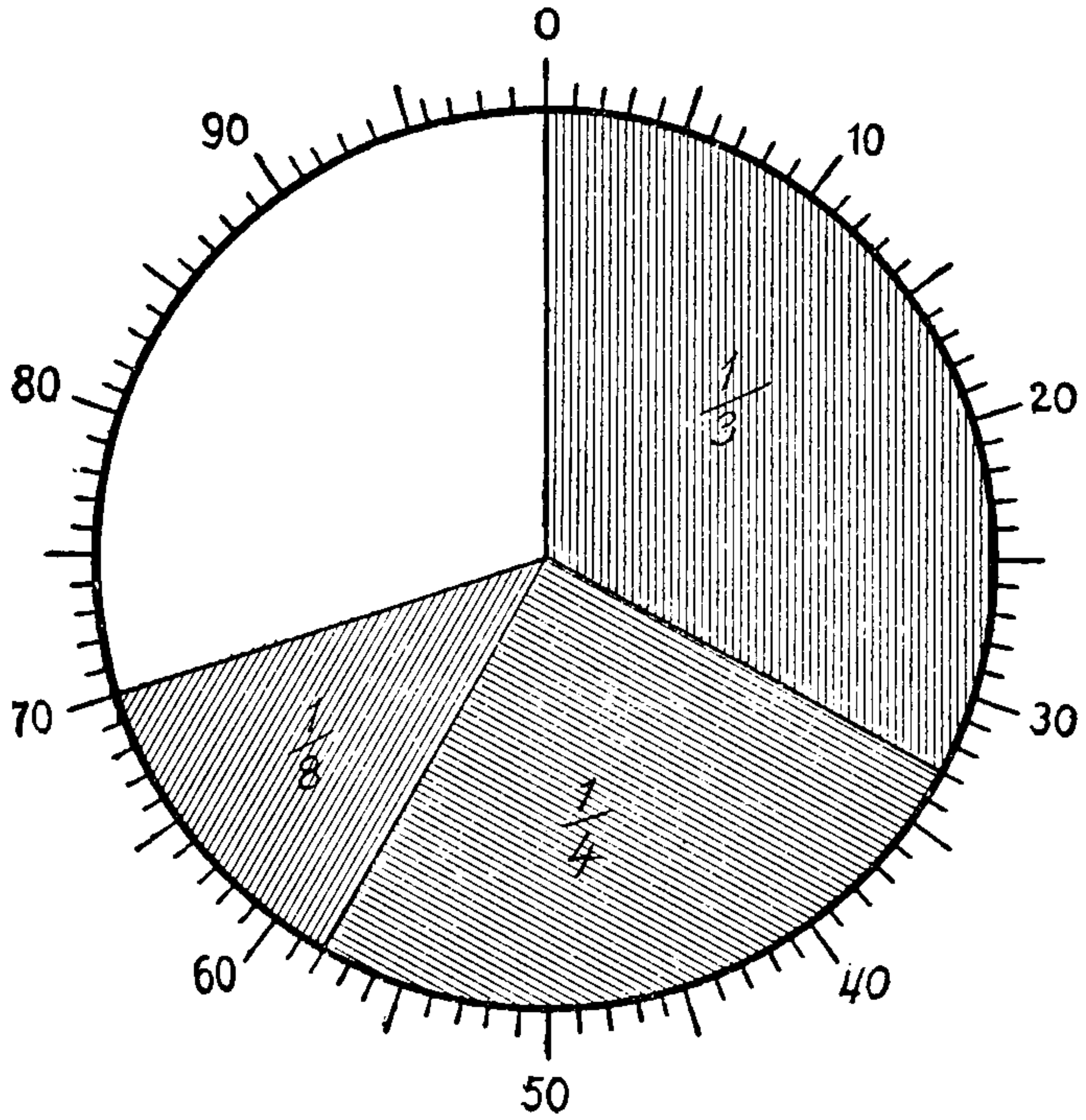

$\frac{1}{3}$, $\frac{1}{4}$, and $\frac{1}{8}$ of a circle are placed within the circle divided into hundredths. Result:

$$\frac{1}{3} + \frac{1}{4} + \frac{1}{8} = 0.70.$$

The lower figure shows how the $\frac{1}{3}$ sector is placed: $\frac{1}{3} = 0.33$.

If instead we use the $\frac{1}{5}$ sector we have: $\frac{1}{5} = 0.20$, etc.

Numerous sectors may be placed within the circle; for example:

$$\frac{1}{4} + \frac{1}{7} + \frac{1}{9} + \frac{1}{10}.$$

In order to find the sum of the fraction reduced to decimals, it is necessary to read only the number at the outer edge of the last sector.

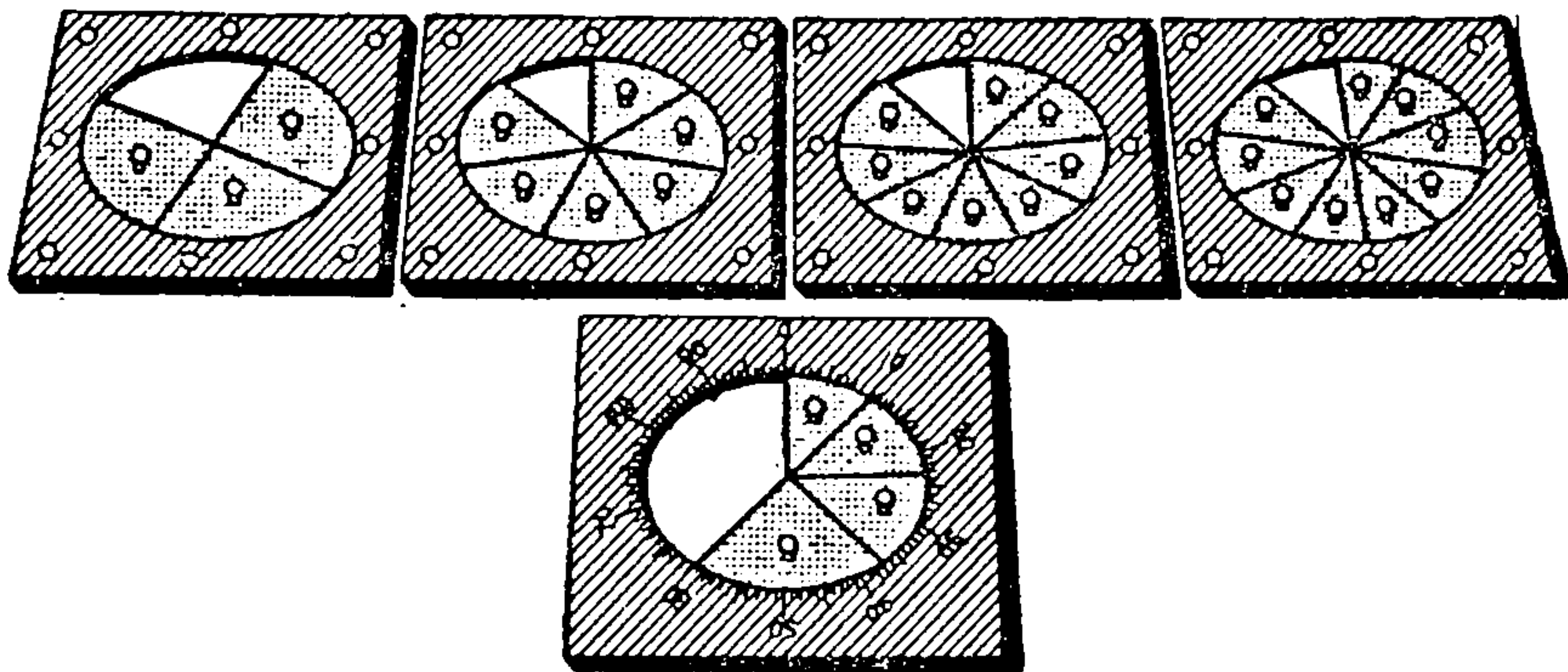

Using this as a basis, it is very easy to develop an arithmetical idea. Instead of 1, which represents the whole circle, let us write 100, which represents its subdivisions when used for decimals, and let us divide the 100 into as many parts of a circle as there are sectors in

the circle, and the reduction is made. All the parts which result are so many hundredths. Hence:

$$\frac{1}{4} = 100 \div 4 = 25 \text{ hundredths: that is, } \frac{25}{100} \text{ or } 0.25.$$

The division is performed by dividing the numerator by the demonator:

$$1 \div 4 = 0.25.$$

THIRD SERIES OF INSETS: *Equivalent Figures*. Two concepts were given by the squares divided into rectangles and triangles: that of fractions and that of equivalent figures.

There is a special material for the concept of fractions which, besides developing the intuitive notion of fractions, has permitted the solution of examples in fractions and of reducing fractions to decimals; and it has furthermore brought cognizance of other things, such as the measuring of angles in terms of degrees.

For the concept of equivalent figures there is still another material. This will lead to finding the area of different geometric forms and also to an intuition of some theorems which heretofore have been foreign to elementary schools, being considered beyond the understanding of a child.

MATERIAL: Showing that a triangle is equal to a rectangle which has one side equal to the base of the triangle, the other side equal to half of the altitude of the triangle.

In a large rectangular metal frame there are two white openings: the triangle and the equivalent rectangle. The pieces which compose the rectangle are such that they may fit into the openings of either the rectangle or the

THIS PAGE IS LOCKED TO FREE MEMBERS

Purchase full membership to immediately unlock this page

Know Your Bible

Forgotten Books' Full Membership provides unlimited access to more than 28,000 volumes of Christian literature for \$8.99/month

**HOLY
BIBLE**

Continue

*Fair use policy applies

there are also an entire rhombus and an entire rectangle. If they are placed one on top of the other they will be

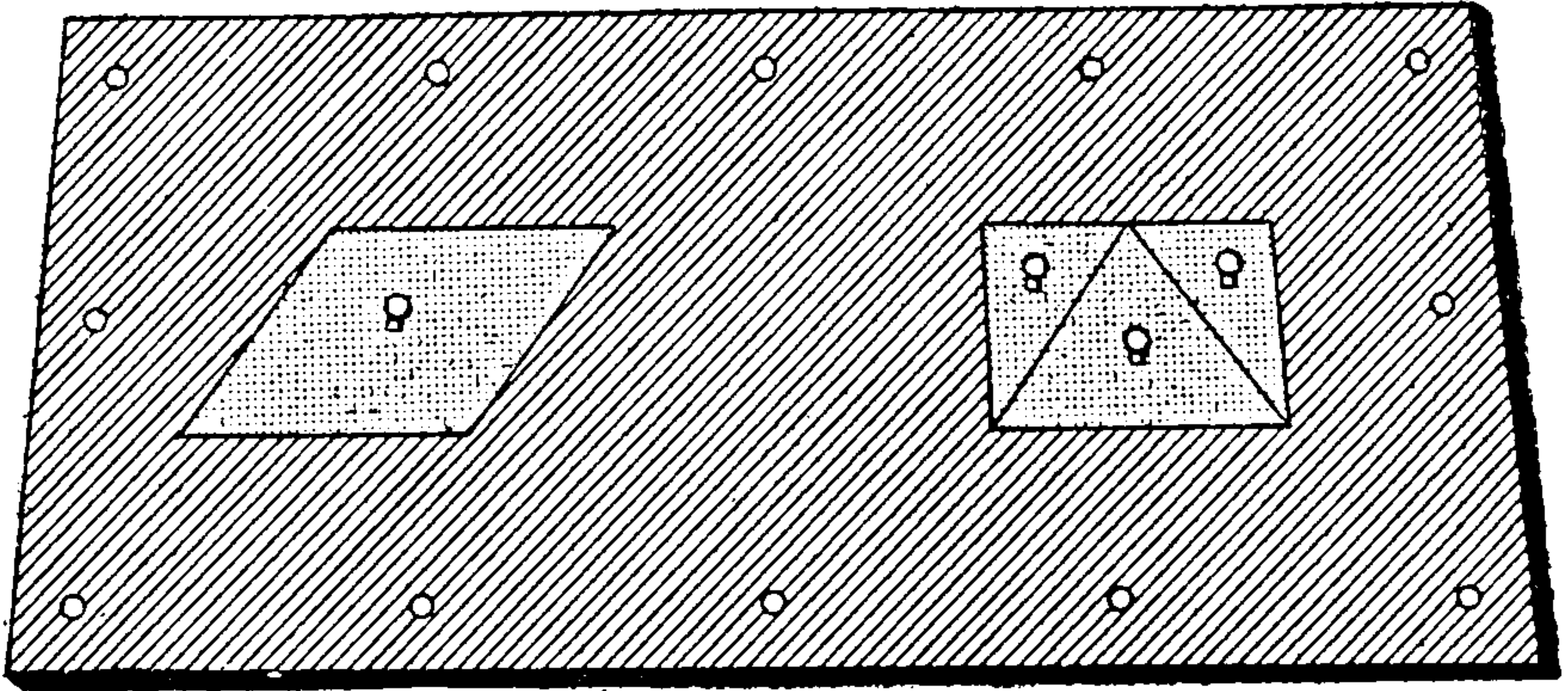

found to have the same height. As the equivalence of the two figures is demonstrated by these pieces of the rectangle which may be used to fill in the two figures, it

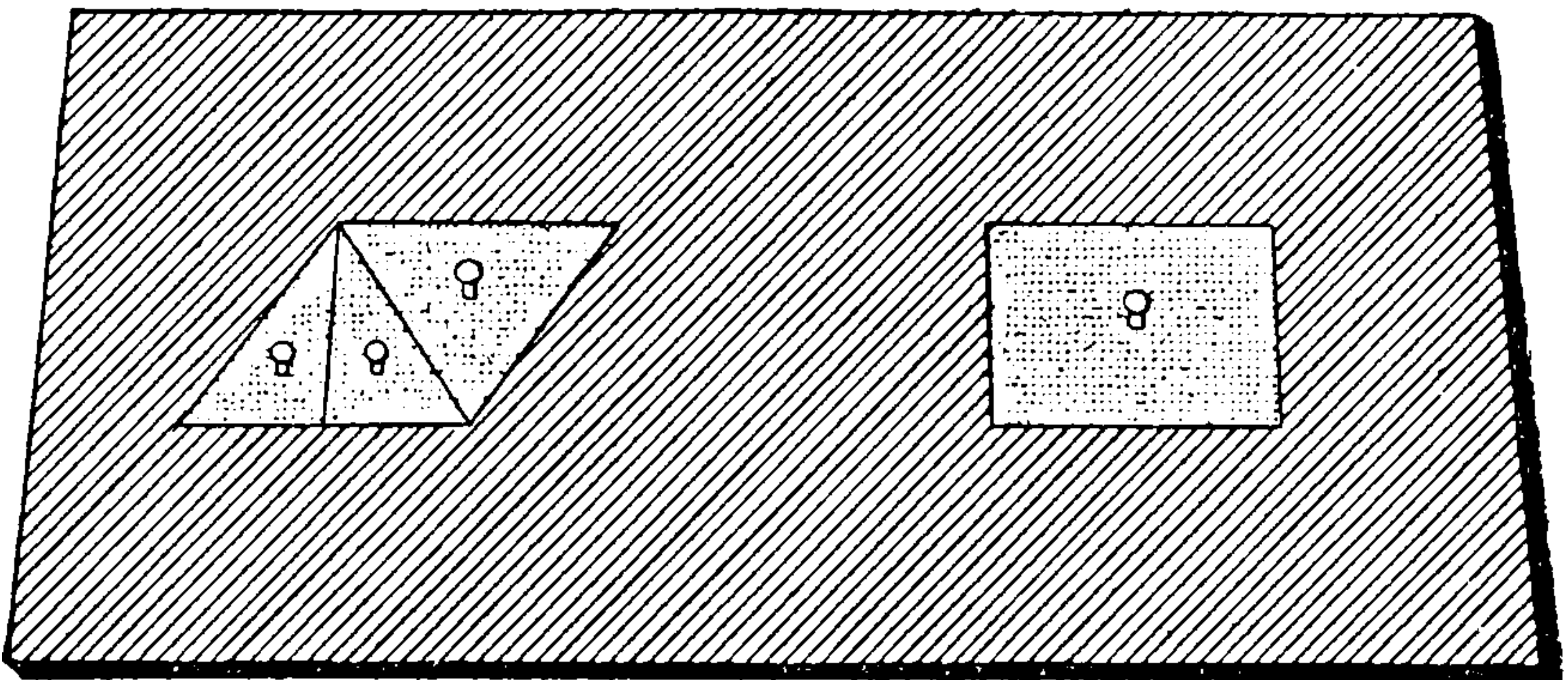

is easily seen that the area of a rhombus is found by multiplying the side or base by the height.

MATERIAL: To show the equivalence of a trapezoid and a rectangle having one side equal to the sum of the two bases and the other equal to half the height.

The child himself can make the other comparison: that is, a trapezoid equals a rectangle having one side equal to the height and the other equal to one-half the sum of

the bases. For the latter it is only necessary to cut the long rectangle in half and superimpose the two halves.

The large rectangular frame contains three openings: two equal trapezoids and the equivalent rectangle having one side equal to the sum of the two bases and the other side equal to half the height. One trapezoid is made of two pieces, being cut in half horizontally at the height of half its altitude; the identity in height may be proved by placing one piece on top of the other. The second

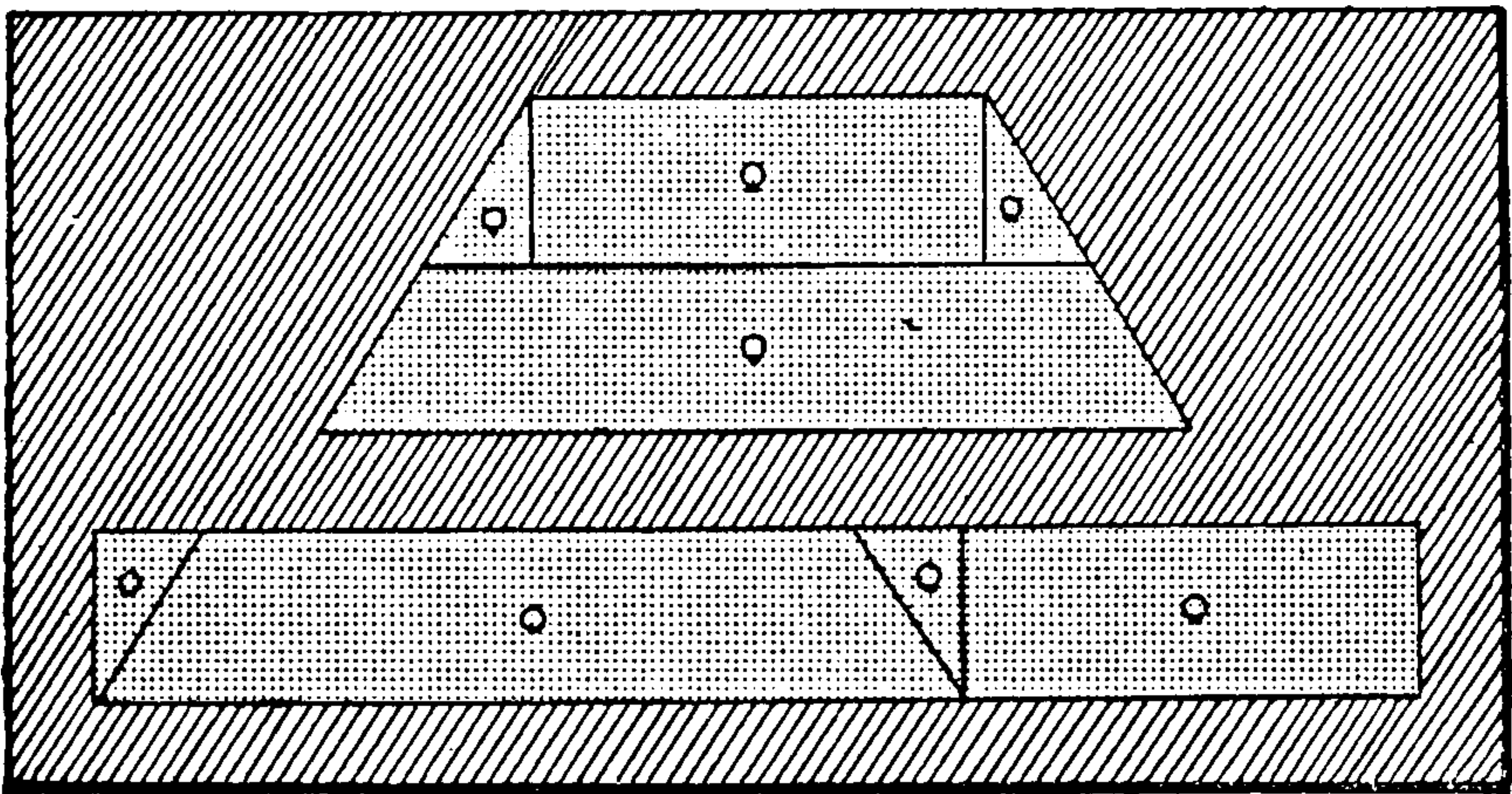

trapezoid is composed of pieces which can be placed in the rectangle, filling it completely. Thus the equivalence is proved and also the fact that the area of a trapezoid is found by multiplying the sum of the bases by half the height, or half the sum of the bases by the height.

With a ruler the children themselves actually calculate the area of the geometrical figures, and later calculate the area of their little tables, etc.

MATERIAL: To show the equivalence between a regular polygon and a rectangle having one side equal to the perimeter and the other equal to half of the hypotenuse.

In the material there are two decagon insets, one con-

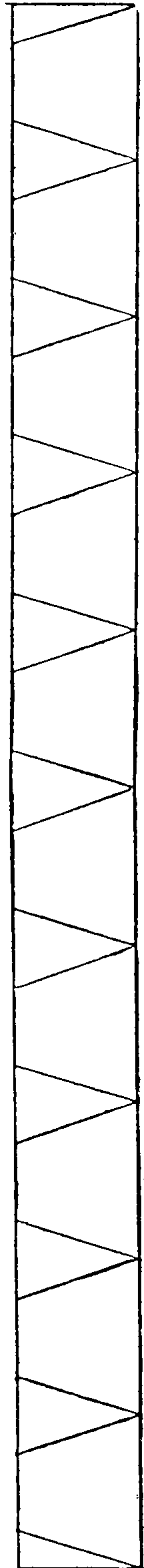
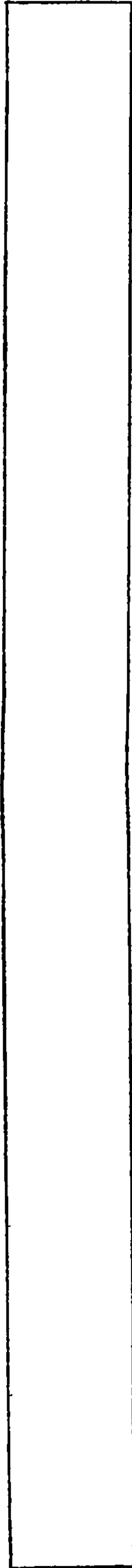
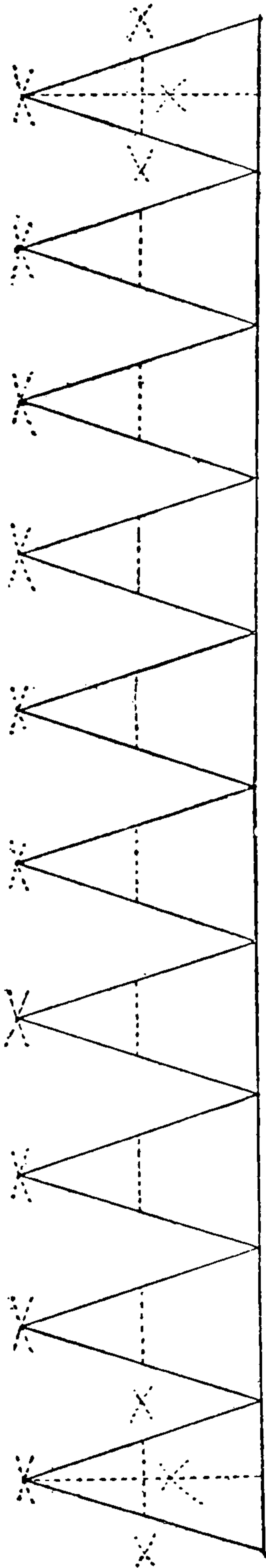

The analysis of the decagon.

THIS PAGE IS LOCKED TO FREE MEMBERS

Purchase full membership to immediately unlock this page



HISTORY

Tens of thousands of important historical sources, many previously unobtainable, are now available for the first time with a Forgotten Books Full Membership.

Unlimited Access
\$8.99/month

Continue

*Fair usage policy applies

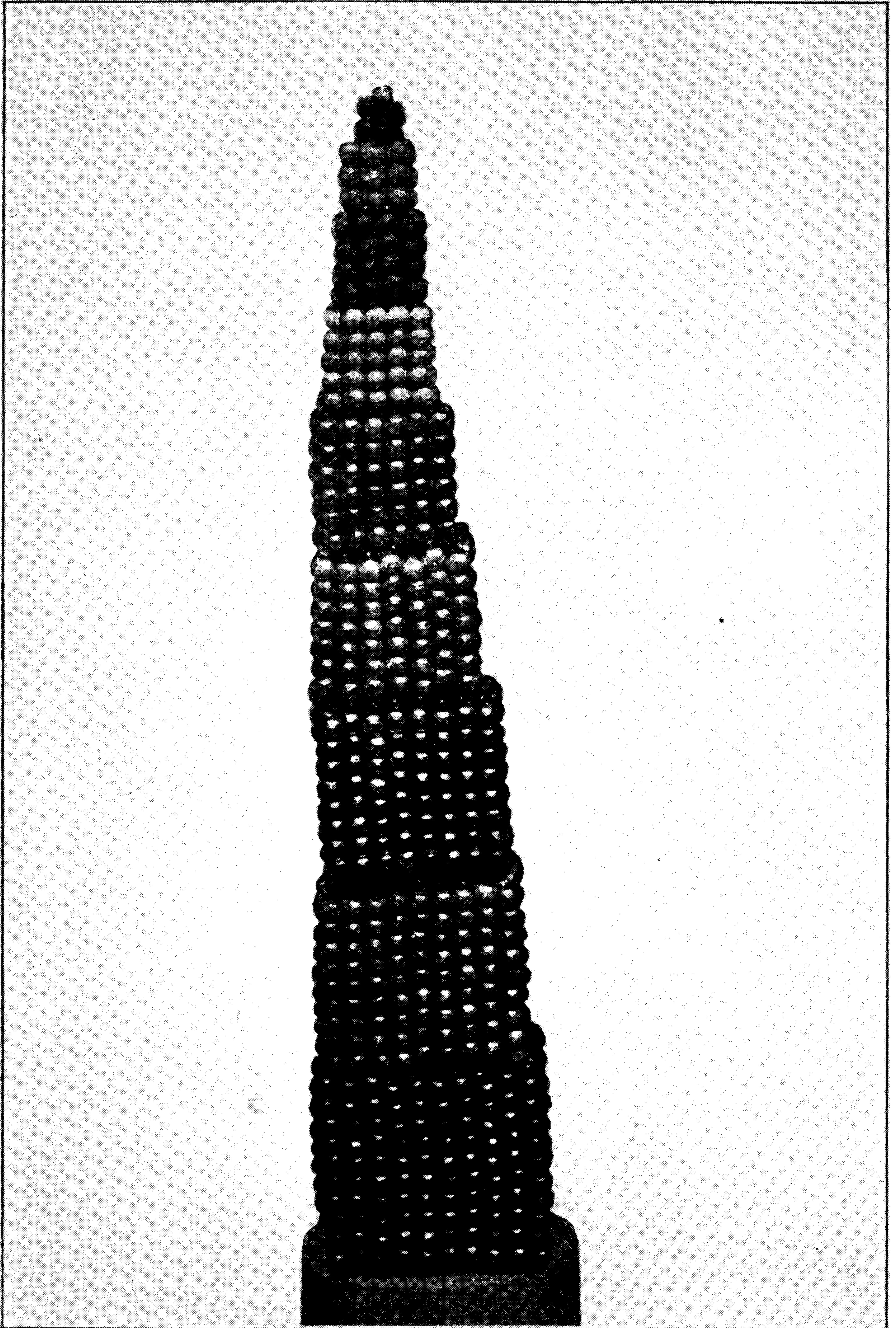

The bead number cubes built into a tower.

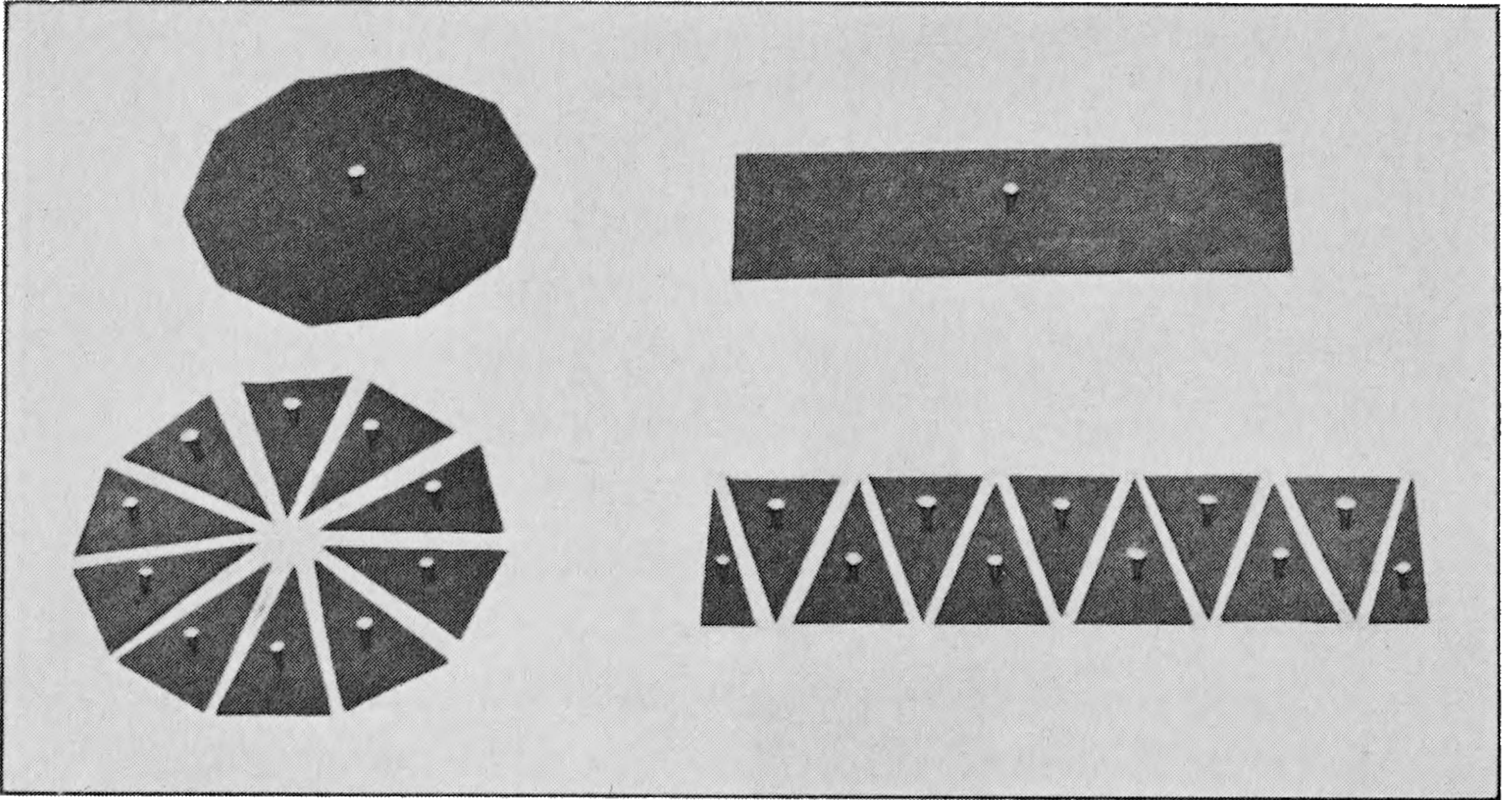

The decagon and the rectangle can be composed of the same triangular insets.

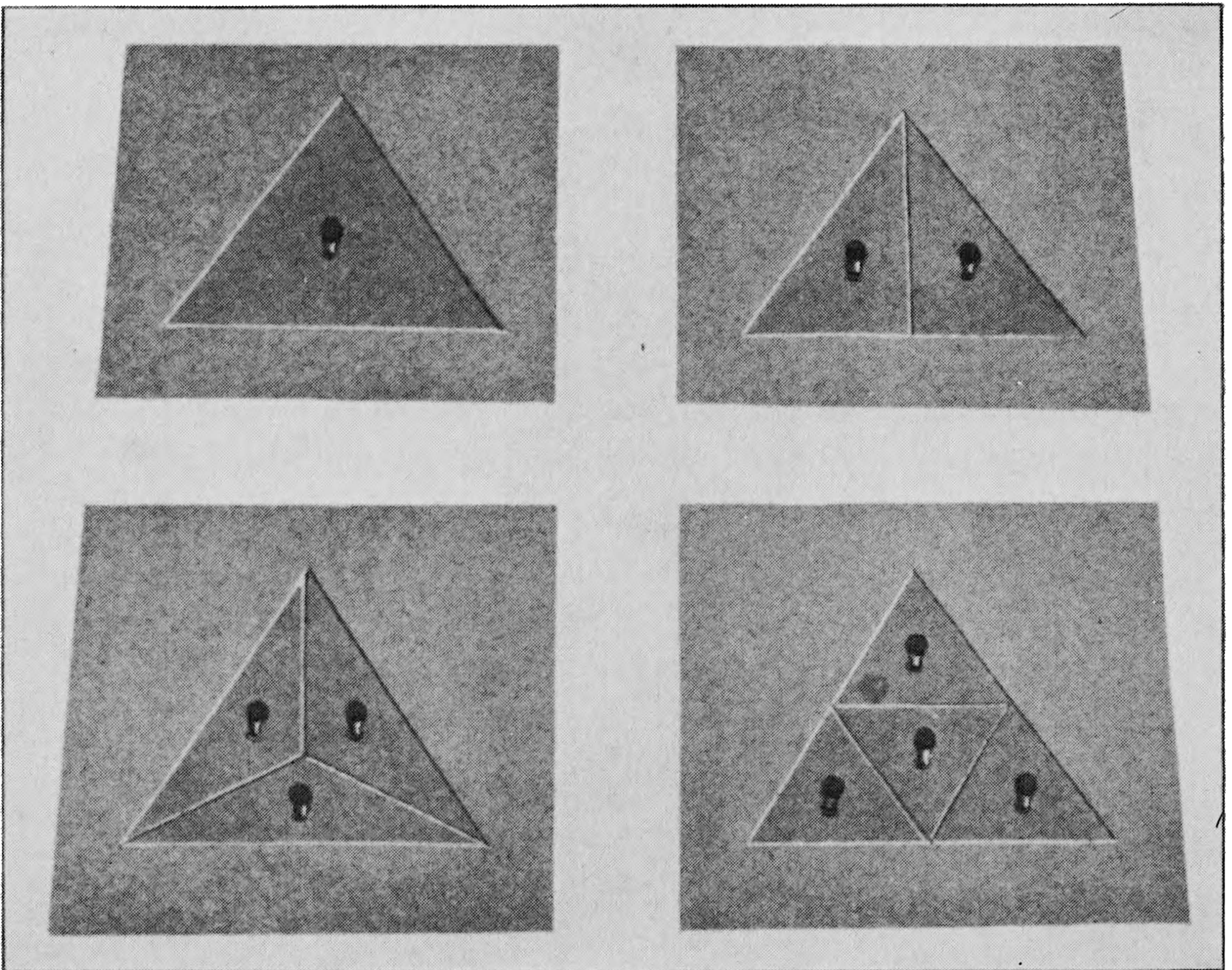

The triangular insets fitted into their metal plates.

alent rectangle are each divided into two triangles. The triangles of the rhombus are different, for they are divided by opposite diagonal lines. The three different triangles resulting from these divisions have the same base (this can be actually verified by measuring the bases of the different pieces) and fit into the same long rectangle which is found below the first three figures. Therefore, it is demonstrated that the three triangles have the same altitude. They are equivalent because each one is the half of an equivalent figure.

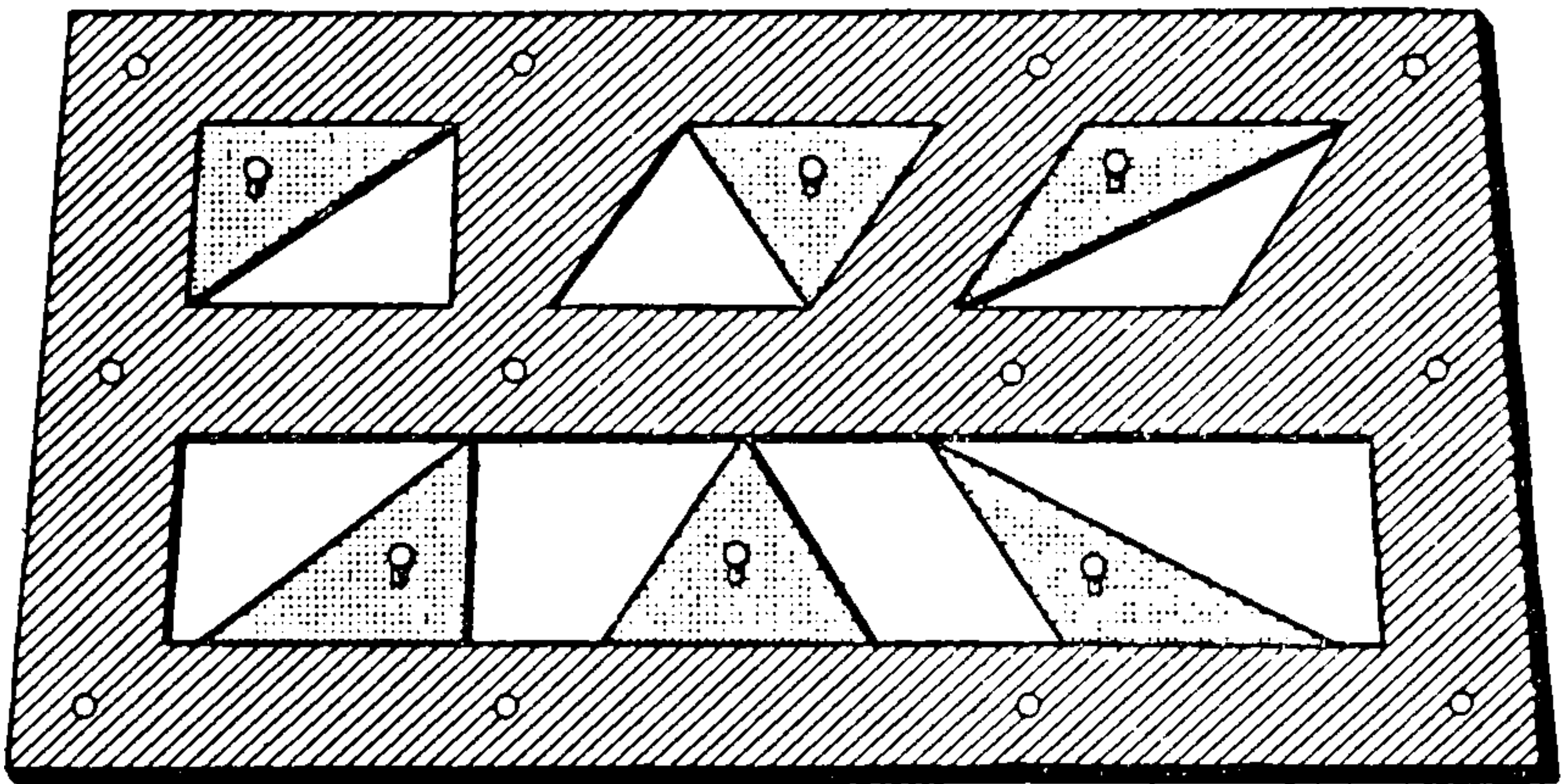

B. THE THEOREM OF PYTHAGORAS: In a right-angled triangle the square of the hypotenuse is equal to the sum of the squares of the two sides.

MATERIAL: The material illustrates three different cases:

First case: In which the two sides of the triangle are equal.

Second case: In which the two sides are in the proportion of 3:4.

Third case: General.

First case: The demonstration of this first case affords an impressive induction.

THIS PAGE IS LOCKED TO FREE MEMBERS

Purchase full membership to immediately unlock this page

Know Your Bible

Forgotten Books' Full Membership provides unlimited access to more than 28,000 volumes of Christian literature for \$8.99/month

**HOLY
BIBLE**

Continue

*Fair use policy applies

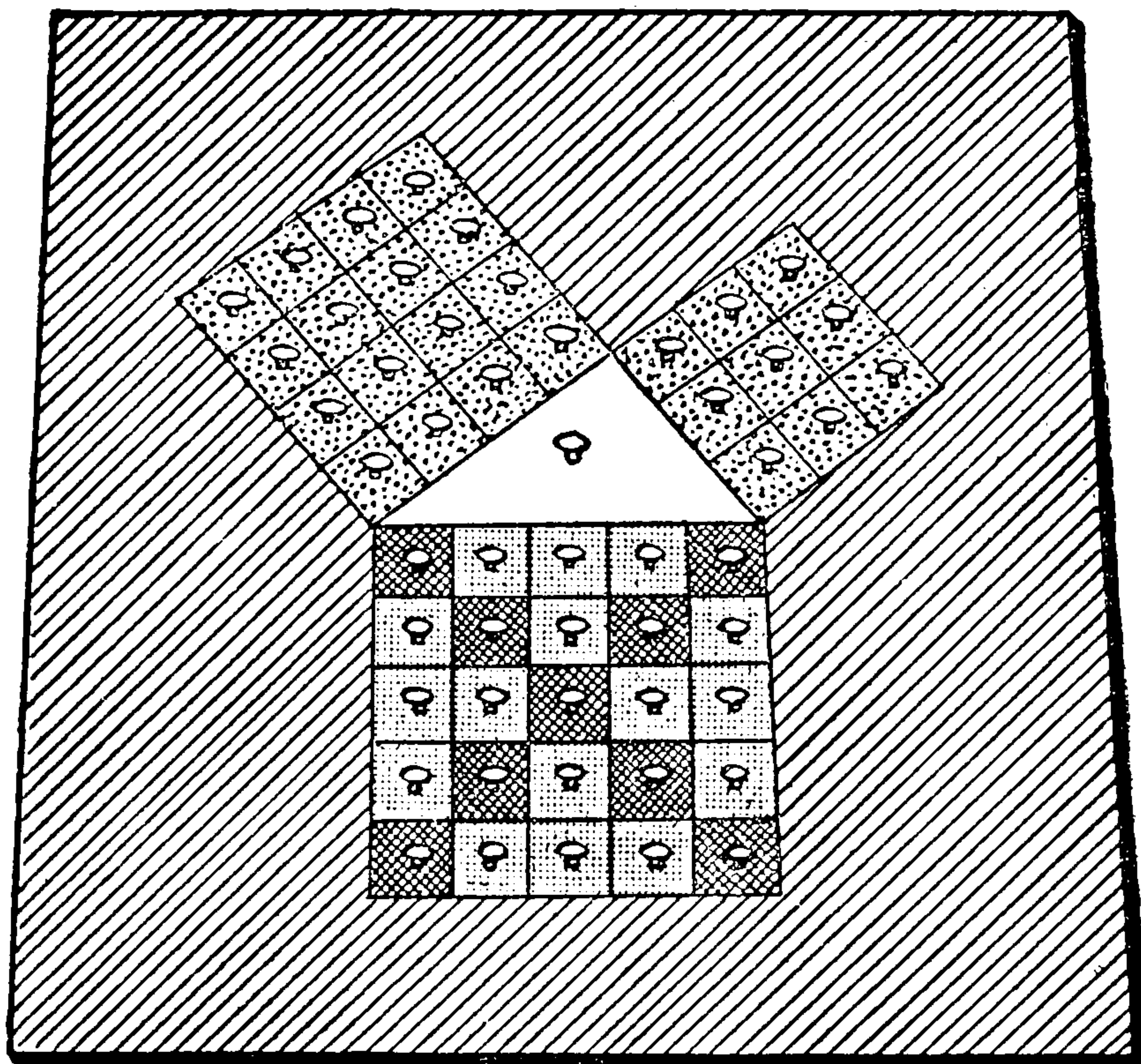
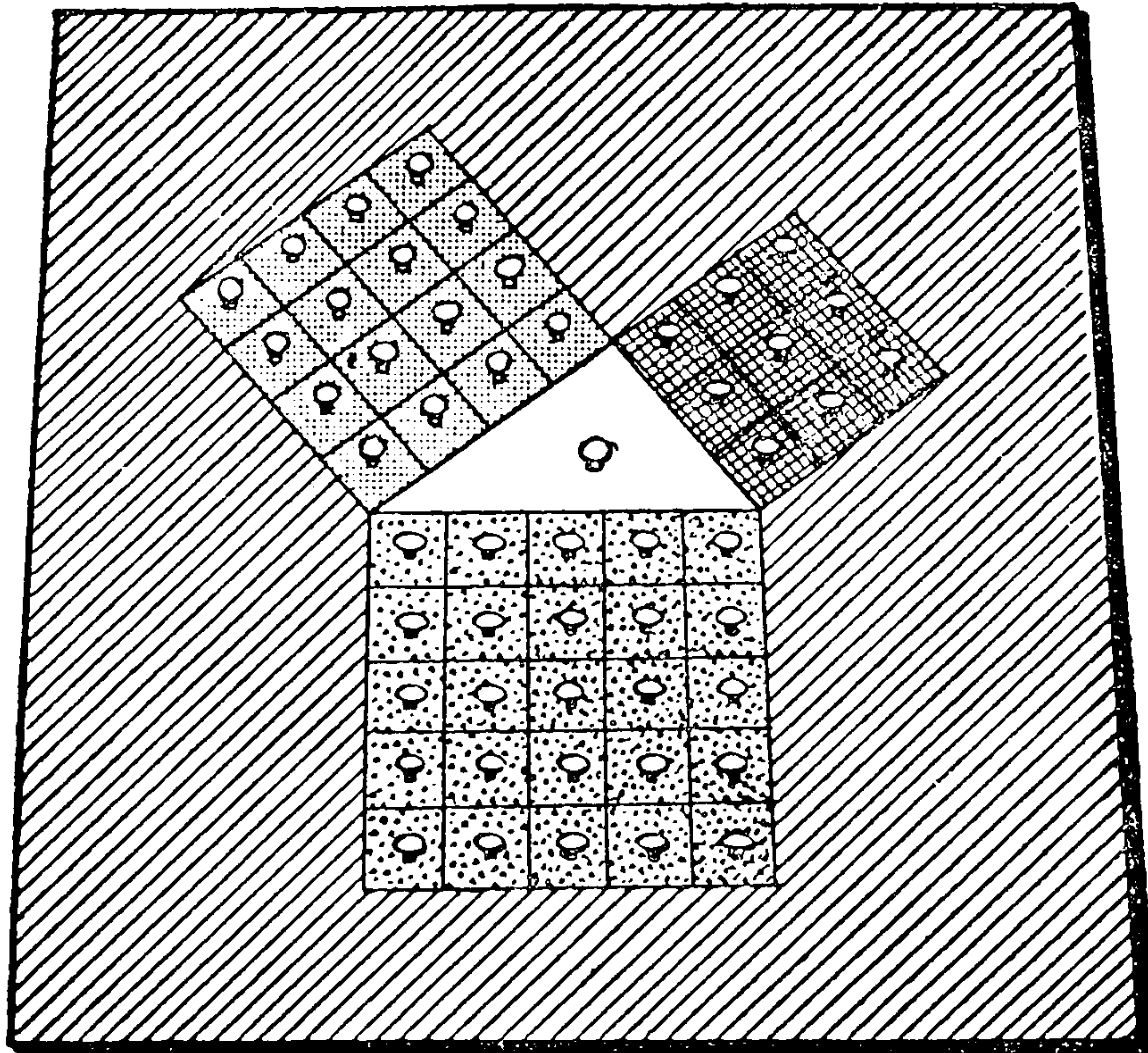

Second Case

so that they are both of the same color; while the square formed on the hypotenuse can be filled with varied designs by various combinations of the small squares of the sides which are in two different colors.

Third case: This is the general case.

The large frame is somewhat complicated and difficult to describe. It develops a considerable intellectual exercise. The entire frame measures 44×24 cm. and may be likened to a chess-board, where the movable pieces are susceptible of various combinations. The principles already proved or inductively suggested which lead to the demonstration of the theorem are:

(1) That two quadrilaterals having an equal base and equal altitude are equivalent.

(2) That two figures equivalent to a third figure are equivalent to each other.

In this figure the square formed on the hypotenuse is divided into two rectangles. The additional side is determined by the division made in the hypotenuse by dropping a perpendicular line from the apex of the triangle to the hypotenuse. There are also two rhomboids in this frame, each of which has one side equal respectively to the large and to the small square of the sides of the triangle and the other side equal to the hypotenuse.

The shorter altitude of the two rhomboids, as may be seen in the figure itself, corresponds to the respective altitudes, or shorter sides, of the rectangles. But the longer side corresponds respectively to the side of the larger and of the smaller squares of the sides of the triangle.

It is not necessary that these corresponding dimensions be known by the child. He sees red and yellow pieces of an inset and simply moves them about, placing them in the indentures of the frame. It is the fact that these

movable pieces actually fit into this white background which gives the child the opportunity for reasoning out the theorem, and not the abstract idea of the corresponding relations between the dimensions of the sides and the different heights of the figures. Reduced to these terms the exercise is easily performed and proves very interesting.

This material may be used for other demonstrations:

DEMONSTRATION A: *The substitution of the pieces.* Let us start with the frame as it should be filled originally. First take out the two rectangles formed on the hypotenuse; place them in the two lateral grooves, and lower the triangle. Fill the remaining empty space with the two rhomboids.

The same space is filled in both cases with:

A triangle plus two rectangles, and then

A triangle plus two rhomboids.

Hence the sum of the two rectangles (which form the square of the hypotenuse) is equal to the sum of the two rhomboids.

In a later substitution we consider the rhomboids instead of the rectangles in order to demonstrate their respective equivalence to the two squares formed on the sides of the triangle. Beginning, for example with the larger square, we start with the insets in the original position and consider the space occupied by the triangle and the larger square. To analyze this space the pieces are all taken out and then it is filled successively by:

The triangle and the large square in their original positions.

The triangle and the large rhomboid.

THIS PAGE IS LOCKED TO FREE MEMBERS

Purchase full membership to immediately unlock this page



HISTORY

Tens of thousands of important historical sources, many previously unobtainable, are now available for the first time with a Forgotten Books Full Membership.

Unlimited Access
\$8.99/month

Continue

*Fair usage policy applies

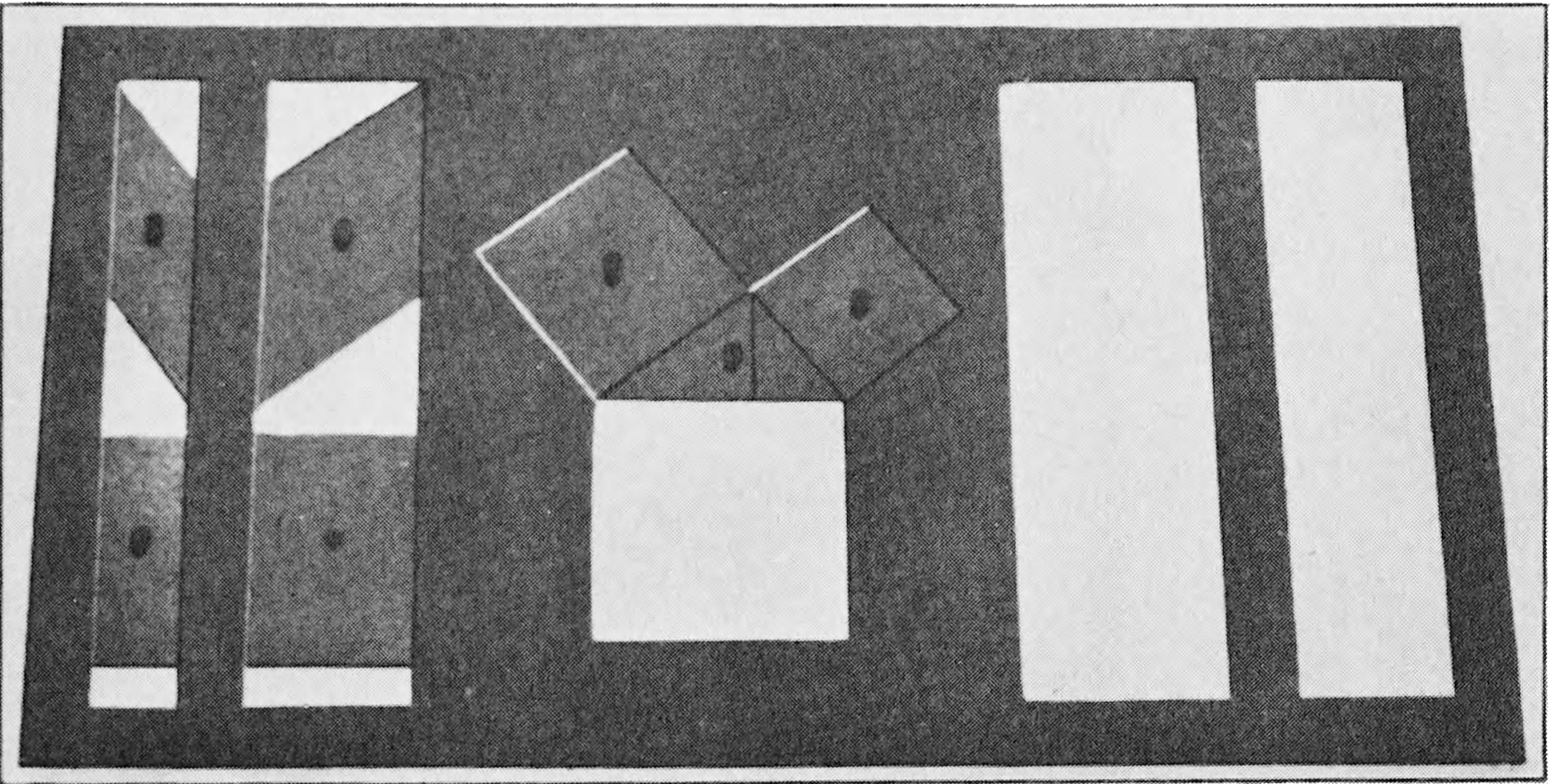
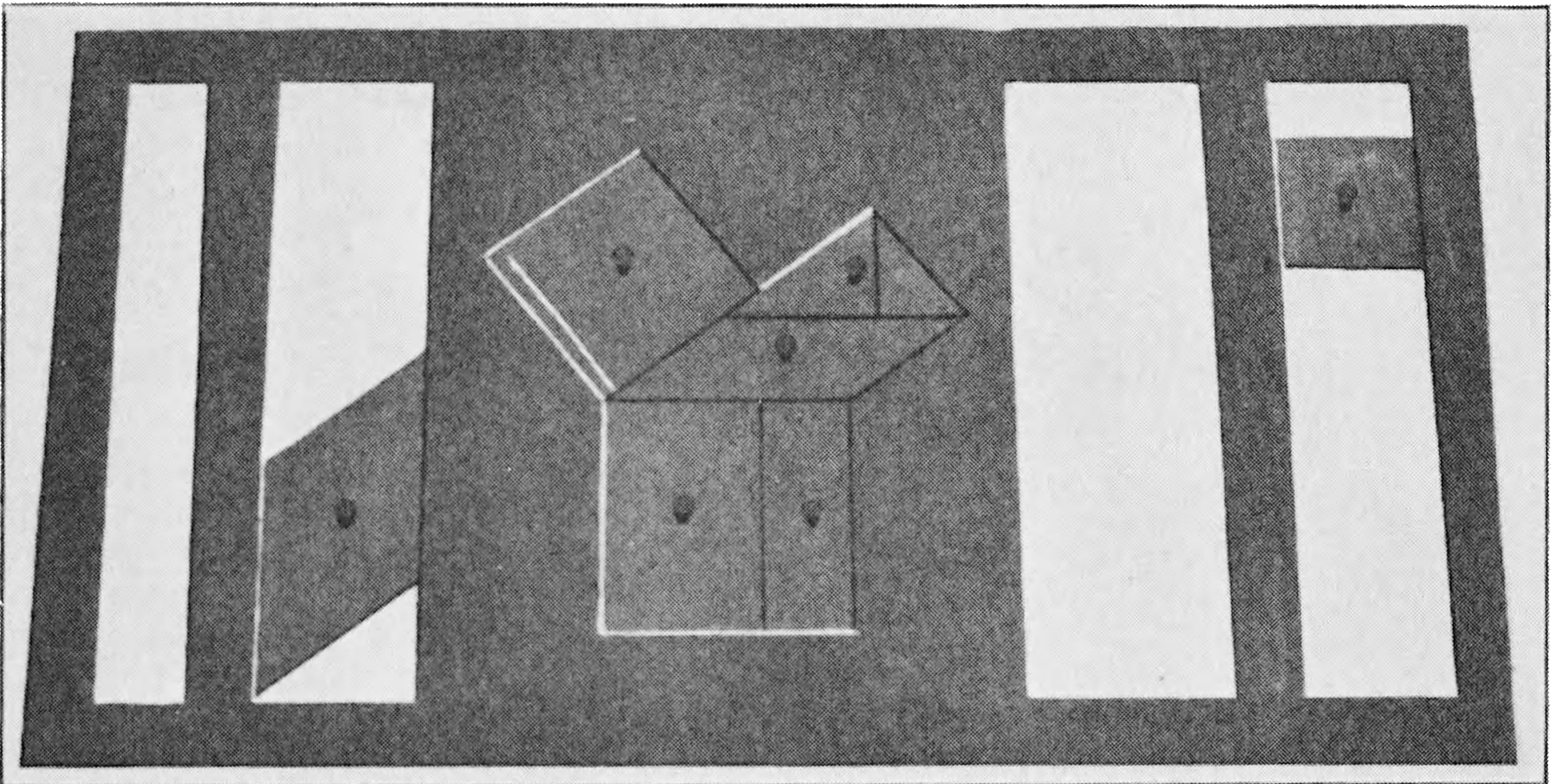
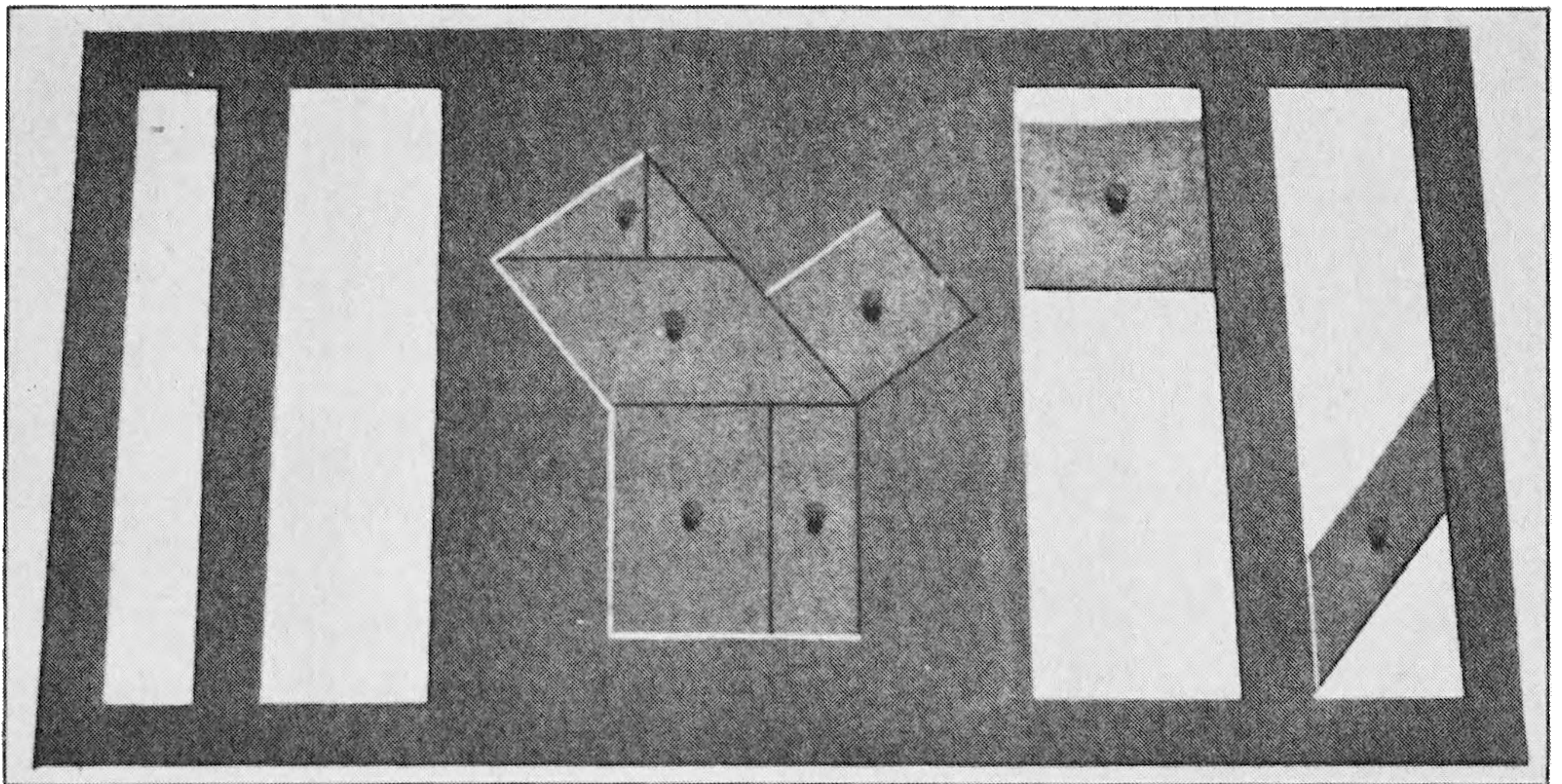

Showing that the two rhomboids are equal to the two rectangles.

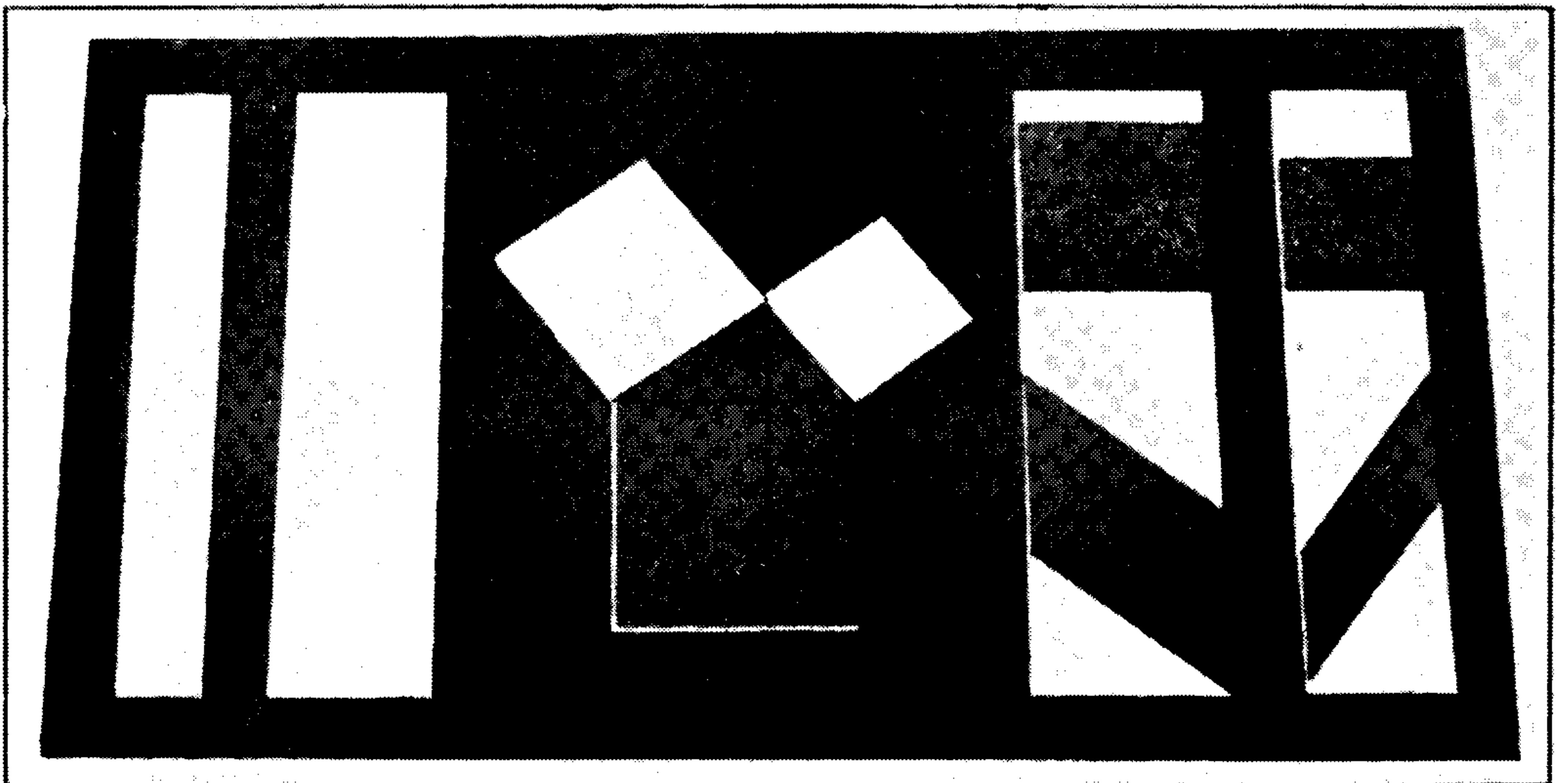
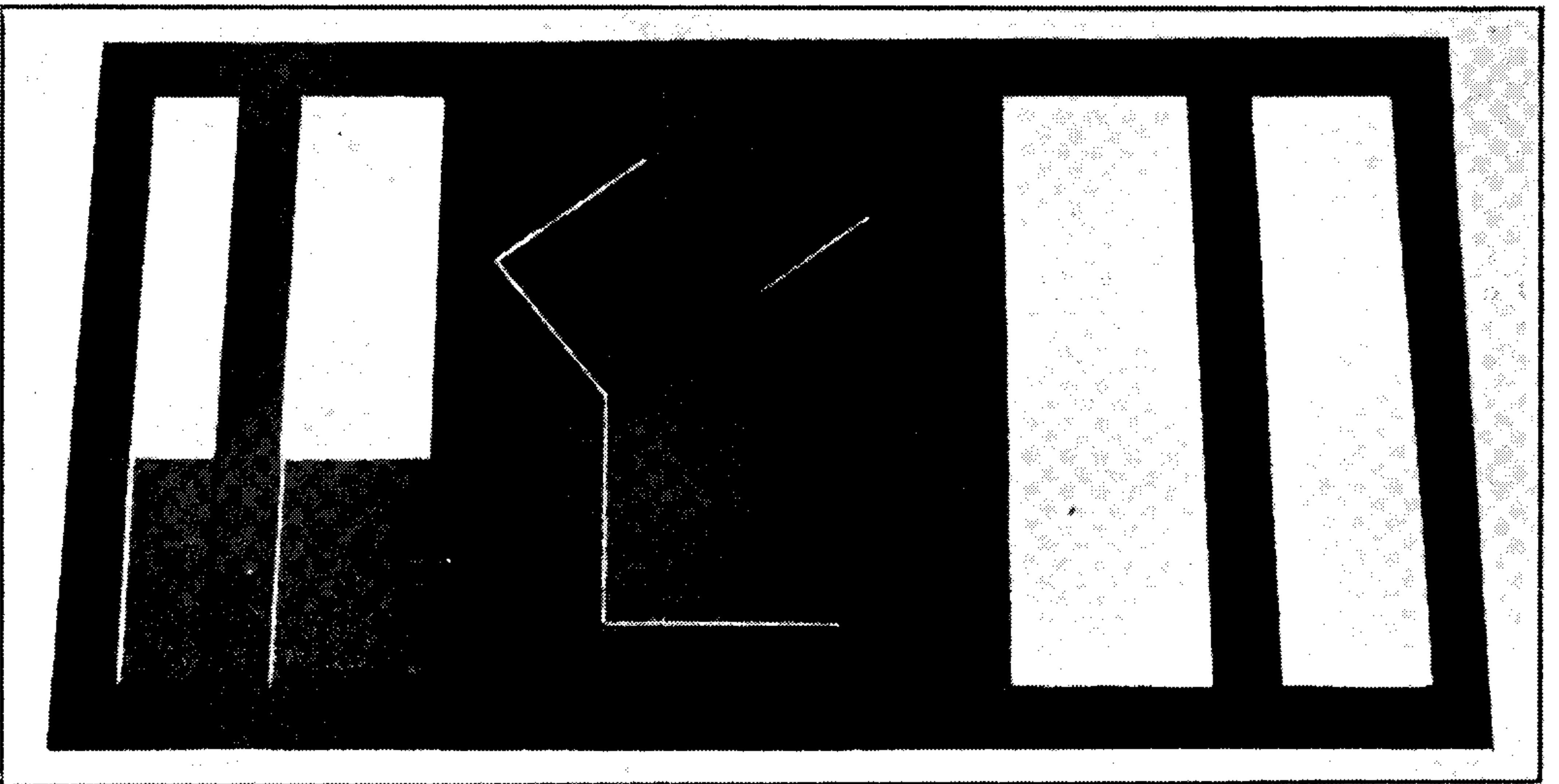
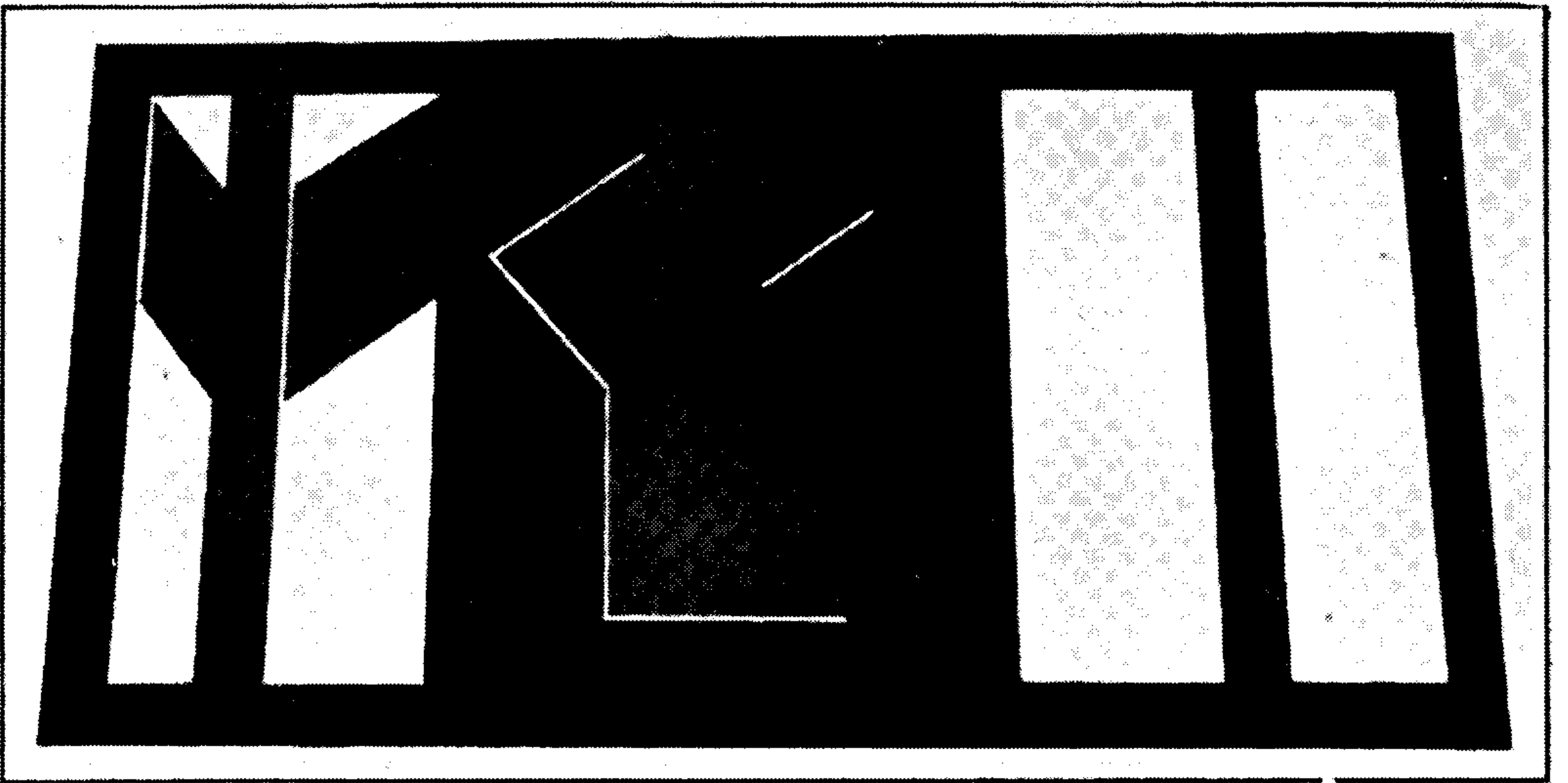

Showing that the two rhomboids are equal to the two squares.

This series of geometric material is used for other purposes, but they are of minor importance.

FOURTH SERIES OF INSETS: *Division of a Triangle.* This material is made up of four frames of equal size, each containing an equilateral triangle measuring ten centimeters to a side. The different pieces should fill the triangular spaces exactly.

One is filled by an entire equilateral triangle.

One is filled by two rectangular scalene triangles, each

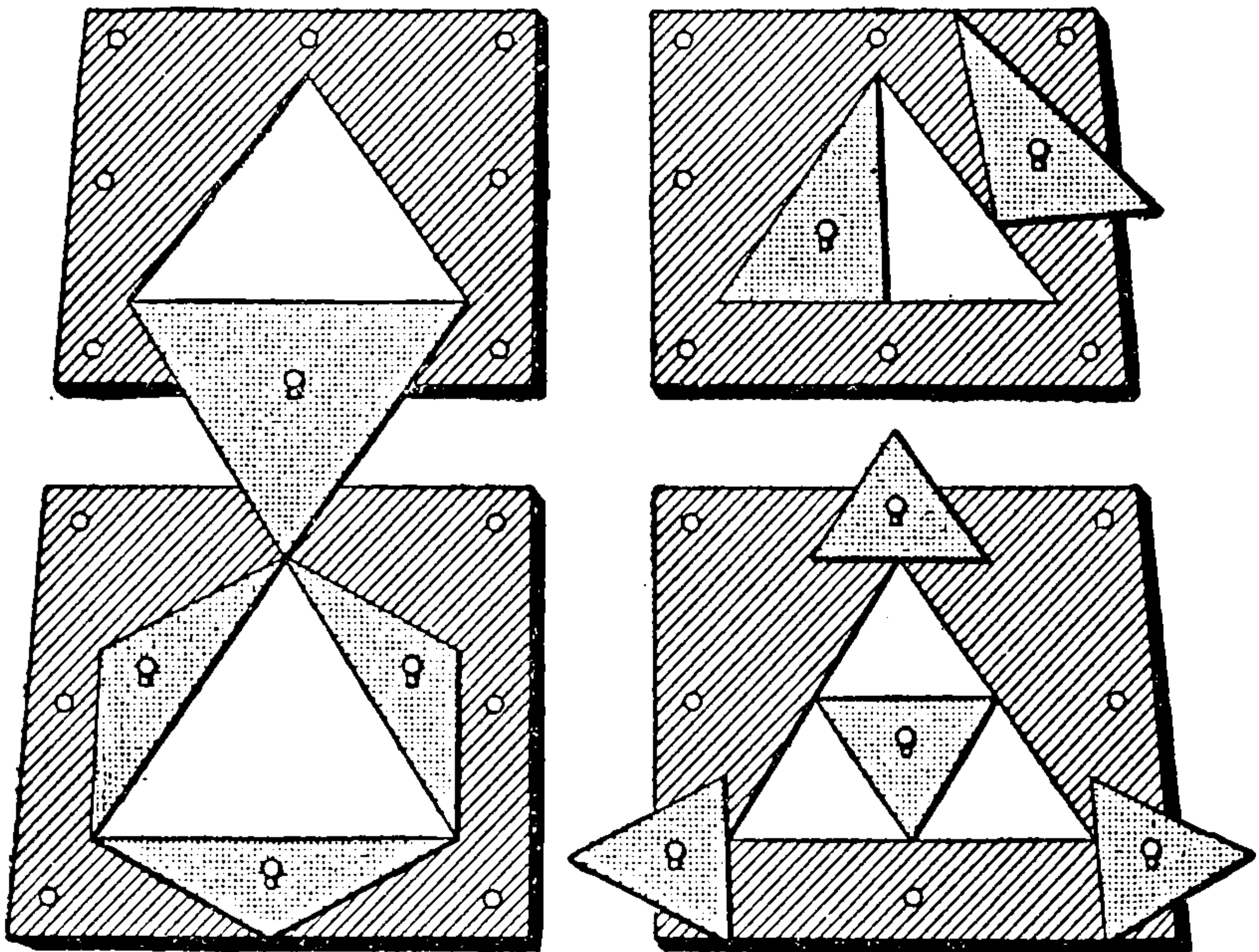

equal to half of the original equilateral triangle, which is bisected by dropping a line perpendicularly to the base.

The third is filled by three obtuse isosceles triangles, formed by lines bisecting the three angles of the original triangle.

The fourth is divided into four equilateral triangles which are similar in shape to the original triangle.

With these triangles a child can make a more exact analytical study than he made when he was observing the

THIS PAGE IS LOCKED TO FREE MEMBERS

Purchase full membership to immediately unlock this page

Know Your Bible

Forgotten Books'
Full Membership
provides unlimited
access to more than
28,000 volumes of
Christian literature for
\$8.99/month

**HOLY
BIBLE**

Continue

*Fair use policy applies

meters square in the 5 centimeters square; and finally the tiny square, which is $\frac{1}{16}$ part of the large square, in the 3.5 centimeters square.

There is also a circle which is tangent to the edges of the large equilateral triangle. This circle may be placed on the background of the 10 centimeters circle, and in that case a white circular strip remains all the way round (concentric circles). Within this circle the smaller equilateral triangle ($\frac{1}{4}$ of the large triangle) is perfectly inscribed. Then there is a small circle which is tangent to the smallest equilateral triangle.

Besides these circles which are used with the triangles there are two others tangent to the squares: one to the 7 centimeters square and the other to the 3.5 centimeters square. The large circle, 10 centimeters in diameter, fits exactly into the 10 centimeters square; and the other circles are concentric to it.

These corresponding relations make the figures easily adaptable to our artistic composition of decorative design (see following chapter).

Finally, together with the other material, there are two stars which are also used for decorative design. The two stars, or "flowers," are based on the 3.5 centimeters square. In one the circle rests on the side as a semi-circle (simple flower); and in the other the same circle goes around the vertex and beyond the semi-circle until it meets the reciprocal of four circles (flower and foliage).

III

SOLID GEOMETRY

Since the children already know how to find the area of ordinary geometric forms it is very easy, with the knowledge of the arithmetic they have acquired through work with the beads (the square and cube of numbers), to initiate them into the manner of finding the volume of solids. After having studied the cube of numbers by the aid of the cube of beads it is easy to recognize the fact that the volume of a prism is found by multiplying the area by the altitude.

In our didactic material we have three objects for solid geometry: a prism, a pyramid having the same base and altitude, and a prism with the same base but with only one-third the altitude. They are all empty. The two prisms have a cover and are really boxes; the uncovered pyramid can be filled with different substances and then emptied, serving as a sort of scoop.

These solids may be filled with wheat or sand. Thus we put into practise the same technique as is used to calculate capacity, as in anthropology, for instance, when we wish to measure the capacity of a cranium.

It is difficult to fill a receptacle completely in such a way that the measured result does not vary; so we usually put in a scarce measure, which therefore does not correspond to the exact volume but to a smaller volume.

One must know how to fill a receptacle, just as one

must know how to do up a bundle, so that the various objects may take up the least possible space. The children like this exercise of shaking the receptacle and getting in as great a quantity as possible; and they like to level it off when it is entirely filled.

The receptacles may be filled also with liquids. In this case the child must be careful to pour out the contents without losing a single drop. This technical drill serves as a preparation for using metric measures.

By these experiments the child finds that the pyramid has the same volume as the small prism (which is one-third of the large prism); hence the volume of the pyramid is found by multiplying the area of the base by one-third the altitude. The small prism may be filled with clay and the same piece of clay will be found to fill the pyramid. The two solids of equal volume may be made of clay. All three solids can be made by taking five times as much clay as is needed to fill the same prism.

•

Having mastered these fundamental ideas, it is easy to study the rest, and few explanations will be needed.

In many cases the incentive to do original problems may be developed by giving the children definite examples: as, how can the area of a circle be found? the volume of a cylinder? of a cone? Problems on the total area of some solids also may be suggested. Many times the children will risk spontaneous inductions and often of their own accord proceed to measure the total surface area of all the solids at their disposal, even going back to the materials used in the "Children's House."

The material includes a series of wooden solids with a base measurement of 10 cm.:

THIS PAGE IS LOCKED TO FREE MEMBERS

Purchase full membership to immediately unlock this page



HISTORY

Tens of thousands of important historical sources, many previously unobtainable, are now available for the first time with a Forgotten Books Full Membership.

Unlimited Access
\$8.99/month

Continue

*Fair usage policy applies

In front are placed two more of the seven cubes $= 2^5$.

On top are put the remaining four equal cubes $= 2^6$.

In this way we have made a cube measuring 8 cm. on a side. From this we see that:

$2^3, 2^6$ have the form of a cube.

$2^2, 2^5$ have the form of a square.

$2, 2^4$ have a linear form.

The Cube of a Binomial: $(a + b)^3 = a^3 + b^3 + 3a^2b + 3b^2a$.

MATERIAL: A cube with a 6 cm. edge, a cube with a 4 cm. edge; three prisms with a square base of 4 cm. on a side and 6 cm. high; three prisms with a square base of 6 cm. to a side and 4 cm. high. The 10 cm. cube can be made with these.

These two combinations are in special cube-shaped boxes into which the 10 cm. cube fits exactly.

Weights and Measures: All that refers to weights and measures is merely an application of similar operations and reasonings.

The children have at their disposal and learn to handle many of the objects which are used for measuring both in commerce and in every-day life. In the "Children's House" days they had the long stair rods which contain the meter and its decimeter subdivisions. Here they have a tape-measure with which they measure floors, etc., and find the area. They have the meter in many forms: in the anthropometer, in the ruler. Then, too,

they use the metal tape, the dressmaker's tape measure, and the meterstick used by merchants.

The twenty centimeter ruler divided into millimeters they use constantly in design; and they love to calculate the area of the geometric figures they have designed or of the metal insets. Often they calculate the surface of the white background of an inset and that of the different pieces which exactly fit this opening, so as to verify the former. As they already have some preparation in decimals it is no task for them to recognize and to remember that the measures increase by tens and take on new names each time. The exercises in grammar have greatly facilitated the increase in their vocabulary.

They calculate the reciprocal relations between length, surface, and volume by going back to the three sets which first represented "long," "thick," and "large."

The objects which differ in length vary by 10's; those differing in areas vary by 100's; and those which differ in volume vary by 1000's.

The comparison between the bead material and the cubes of the pink tower (one of the first things they built) encourages a more profound study of the sensory objects which were once the subject of assiduous application.

By the aid of the double decimeter the children make the calculations for finding the volume of all the different objects graded by tens, such as the rods, the prisms of the broad stair, the cubes of the pink tower.

By taking the extremes in each case they learn the relations between objects which differ in one dimension, in two dimensions, and in three dimensions. Besides, they already know that the square of 10 is 100, and the cube of 10 is 1000.

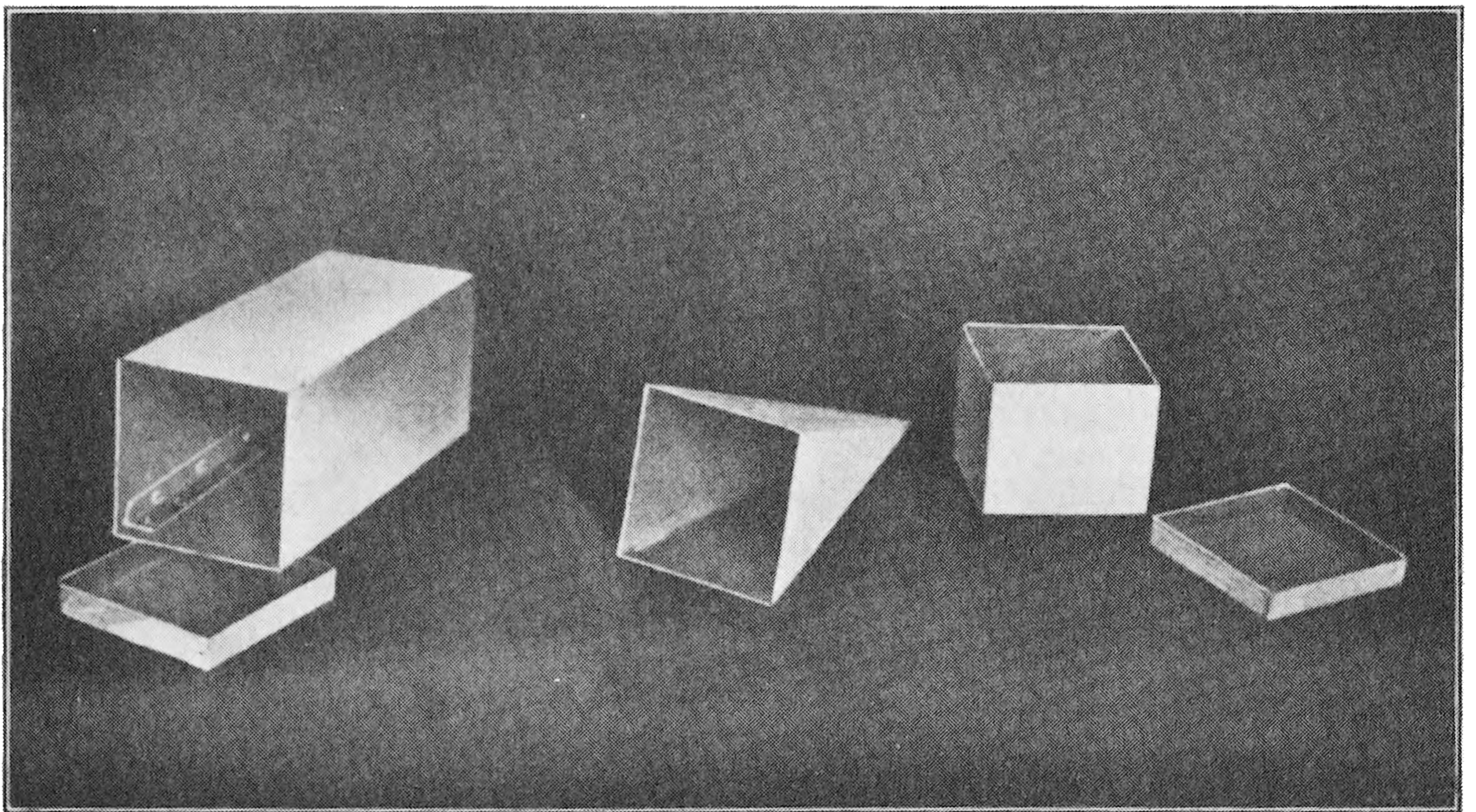
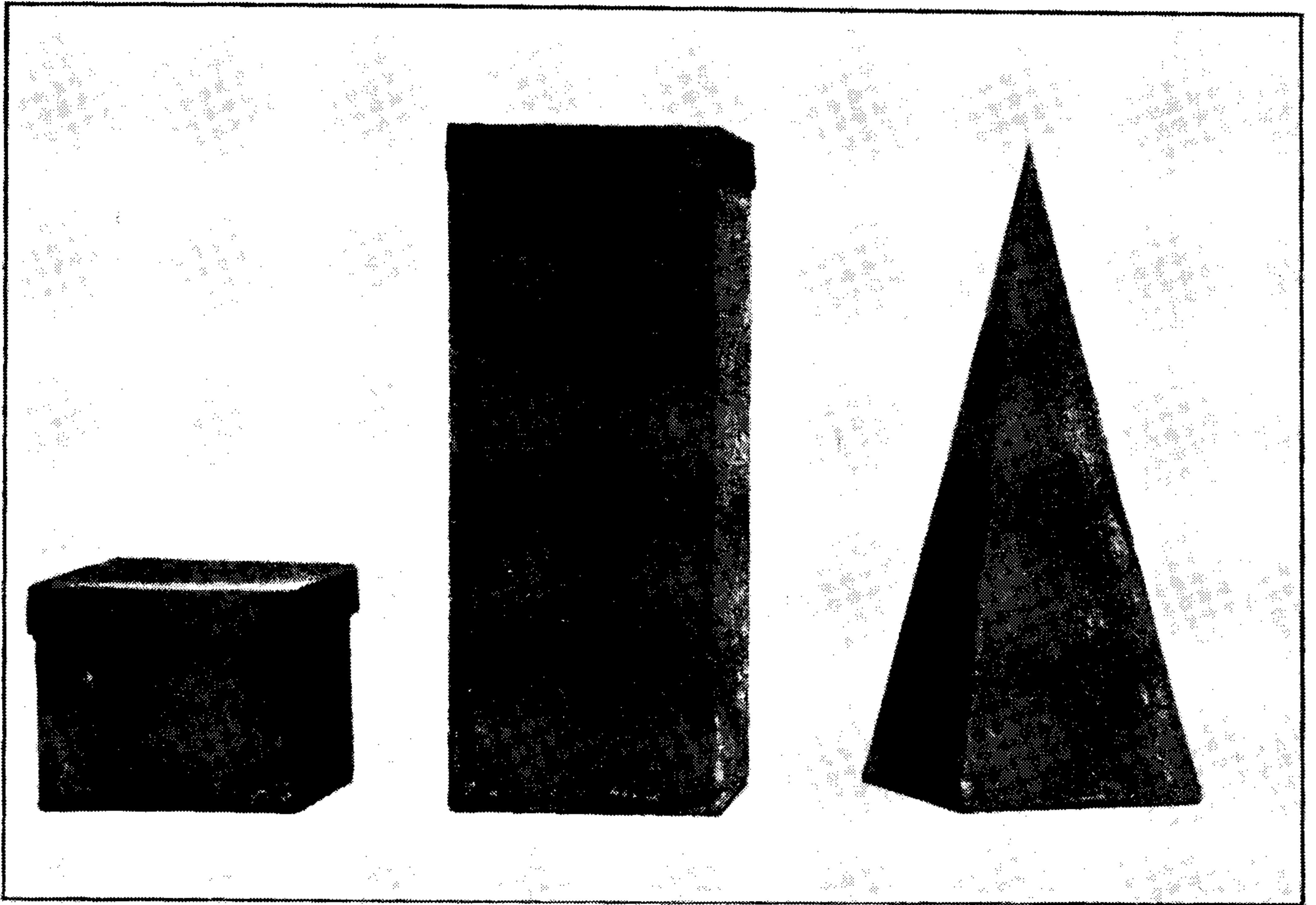

Hollow geometric solids, used for determining equivalence by measuring sand, sugar, etc.

THIS PAGE IS LOCKED TO FREE MEMBERS

Purchase full membership to immediately unlock this page

Know Your Bible

Forgotten Books'
Full Membership
provides unlimited
access to more than
28,000 volumes of
Christian literature for
\$8.99/month

**HOLY
BIBLE**

Continue

*Fair use policy applies

The children make use of various scientific instruments: thermometers, distillers, scales, and, as previously stated, the principal measures commonly used.

By filling an empty metal cubical decimeter, which like the geometric solids is used for the calculation of volume, they have a liter measure of water, which may be poured into a glass liter bottle. All the decimal multiples and subdivisions of the liter are easily understood. Our children spent much time pouring liquids into all the small measures used in commerce for measuring wine and oil.

They distil water with the distiller. They use the thermometer to measure the temperature of water in ebullition and the temperature of the freezing mixture. They take the water which is used to determine the weight of the kilogram, keeping it at the temperature of 4°C.

The objects which serve to measure capacity also are at the disposal of the children.

There is no need to go into more details upon the multitudinous consequences resulting from both a methodical preparation of the intellect and the possibility of actually being in contact with real objects.

A great number of problems given by us, as well as problems originated by the children themselves, bear witness to the ease with which external effects may be spontaneously produced when once the inner *causes* have been adequately stimulated.

PART V
DRAWING

THIS PAGE IS LOCKED TO FREE MEMBERS

Purchase full membership to immediately unlock this page



HISTORY

Tens of thousands of important historical sources, many previously unobtainable, are now available for the first time with a Forgotten Books Full Membership.

Unlimited Access
\$8.99/month

Continue

*Fair usage policy applies

I

LINEAR GEOMETRIC DESIGN DECORATION

I already have mentioned the fact that the material of the geometric insets may be applied also to design.

It is through design that the child may be led to ponder on the geometric figures which he has handled, taken out, combined in numerous ways, and replaced. In doing this he completes an exercise necessitating much use of the reasoning faculties. Indeed, he reproduces all of the figures by linear design, learning to handle many instruments — the centimeter ruler, the double decimeter, the square, the protractor, the compass, and the steel pen used for line ruling. For this work we have included in the geometric material a large portfolio where, together with the pages reproducing the figures, there are also some illustrative sheets with brief explanations of the figures and containing the relative nomenclature. Aside from copying designs the child may copy also the explanatory notes and thus reproduce the whole geometry portfolio. These explanatory notes are very simple. Here, for example, is the one which refers to the square:

“**SQUARE:** The side or base is divided into 10 cm. All the other sides are equal, hence each measures 10 cm. The square has four equal sides and four equal angles which are always right angles. The number 4 and the identity of the sides and angles are the distinguishing characteristics of the square.”

The children measure paper and construct the figure

with attention and application that are truly remarkable. They love to handle the compasses and are very proud of possessing a pair.

One child asked her mother for a Christmas gift of "one *last* doll and a box of compasses," as if she were ending one epoch of her life and beginning another. One little boy begged his mother to let him accompany her when she went to buy the compass for him. When they were in the store the salesman was surprised to find that so young a child was to use the compass and gave them a box of the simplest kind. "Not those," protested the little fellow; "I want an engineer's compass;" and he picked out one of the most complicated ones. This was the very reason why he was so anxious to go with his mother.

As the children draw, they learn many particulars concerning the geometric figures: the sides, angles, bases, centers, median lines, radii, diameters, sectors, segments, diagonals, hypotenuses, circumferences, perimeters, etc. They do not, however, learn all this as so much dry information nor do they limit themselves to reproducing the designs in the geometry portfolio. Each child adds to his own portfolio other designs which he chooses and sometimes originates. The designs reproduced in the portfolio are drawn on plain white drawing paper with China inks, but the children's special designs are drawn on colored paper with different colored inks and with gildings (silver, gold). The children reproduce the geometric figures and then they fill them in with decorations made either with pen or water-colors. These decorations serve especially to emphasize, in a geometric analysis, the various parts of the figure, such as center, angles, circumference, medians, diagonals, etc.

The decorated motif is selected or else invented by the child himself. He is allowed the same freedom of choice in his backgrounds as he enjoys for his inks or water-colors. The observation of nature (flowers and their different parts — pollen, leaves, a section of some part observed under the microscope, plant seeds, shells, etc.) serves to nourish the child's æsthetic imagination. The children also have access to artistic designs, collections of photographs reproducing the great masterpieces, and Haeckel's famous work, *Nature's Artistic Forms*, all of which equipment is so interesting and delightful to a child.

The children work many, many hours on drawing. This is the time we seize for reading to them (see above p. 197) and almost all their history is learned during this quiet period of copy and simple decoration which is so conducive to concentration of thought.

Copying some design, or drawing a decoration which has been directly inspired by something seen; the choice of colors to fill in a geometric figure or to bring out, by small and simple designs, the center or side of the figure; the mechanical act of mixing a color, of dissolving the gildings, or of choosing one kind of ink from a series of different colors; sharpening a pencil, or getting one's paper in the proper position; determining through tentative means the required extension of the compass — all this is a complex operation requiring patience and exactitude. But it does not require great intellectual concentration. It is, therefore, a work of application rather than of inspiration; and the observation of each detail, in order to reproduce it exactly, clarifies and rests the mind instead of rousing it to the intense activity demanded by the labor of association and creation. The

THIS PAGE IS LOCKED TO FREE MEMBERS

Purchase full membership to immediately unlock this page

Know Your Bible

Forgotten Books'
Full Membership
provides unlimited
access to more than
28,000 volumes of
Christian literature for
\$8.99/month

**HOLY
BIBLE**

Continue

*Fair use policy applies

dren abandon their drawing so as to act out some humorous selection or to represent an historical fact which has touched them deeply; or, indeed, as happened during the reading of the *Savage of Aveyron*, their hands remained almost unconsciously raised in the intensity of their emotion, while on their faces was an expression of ecstasy, as if they were witnessing wonderful unheard-of things. Their actions seemed to interpret the well-known sentiment: "Never have I seen woman like unto this."

ARTISTIC COMPOSITION WITH THE INSETS: Our geometric insets, which are all definitely related to one another in dimensions and include a series of figures which can be contained one within the other, lend themselves to very beautiful combinations. With these the children make real creations and often follow out their artistic ideas for days and even weeks. By moving the small pieces or by combining them in different ways on the white background, these very insets produce various decorations. The ease with which the child may form designs by arranging the little pieces of iron on a sheet of paper and then outlining them, and the harmony which is thus so easily obtained, affords endless delight. Really wonderful pieces of work are often produced in this way.

During these periods of creative design, as indeed during the periods of drawing from life, the child is deeply and wholly concentrated. His entire intellect is at work and no kind of instructive reading would be at all fitting while he is engaged in drawing or designing of this nature.

With the insets, as we have said, we have reproduced some of the classic decorations so greatly admired in the

Italian masterpieces; for instance, those of Giotto in Florentine Art. When the children try with the insets to reproduce these classic decorations from photographs they are led to make most minute observations, which may be considered a real study of art. They judge the relative proportions of the various figures in such a way that their eye learns to appreciate the harmony of the work. And thus, even in childhood, a fine æsthetic enjoyment begins to engage their minds on the higher and more noble planes.

II

FREE-HAND DRAWING—STUDIES FROM LIFE

All the preceding exercises are “formative” for the art of drawing. They develop in the child the manual ability to execute a geometric design and prepare his eye to appreciate the harmony of proportions between geometric figures. The countless observations of drawings, the habit of minute examination of natural objects, constitute so many preparatory drills. We can, however, say that the whole method, educating the eye and the hand at the same time and training the child to observe and execute drawings with intense application, prepares the mechanical means for design, while the mind, left free to take its flight and to create, is ready to produce.

It is by developing the individual that he is prepared for that wonderful manifestation of the human intelligence, which drawing constitutes. The ability *to see reality* in form, in color, in proportion, to be master of the movements of one's own hand — that is what is necessary. Inspiration is an individual thing, and when a child possesses these formative elements he can give expression to all he happens to have.

There can be no “graduated exercises in drawing” leading up to an artistic creation. That goal can be attained only through the development of mechanical technique and through the freedom of the spirit. That

THIS PAGE IS LOCKED TO FREE MEMBERS

Purchase full membership to immediately unlock this page



HISTORY

Tens of thousands of important historical sources, many previously unobtainable, are now available for the first time with a Forgotten Books Full Membership.

Unlimited Access
\$8.99/month

Continue

*Fair usage policy applies

reproduction; and who when left free to create and express himself actually does create and express himself.

The sensory and manual preparation for drawing is nothing more than an alphabet; but without it the child is an illiterate and cannot express himself. And just as it is impossible to study the writing of people who cannot write, so there can be no psychological study of the drawings of children who have been abandoned to spiritual and muscular chaos. All psychic expressions acquire value when the inner personality has acquired value by the development of its formative processes. Until this fundamental principle has become an absolute acquisition we can have no idea of the psychology of a child as regards his creative powers.

Thus, unless we know how a child should develop in order to unfold his natural energies, we shall not know how drawing as a natural expression is developed. The universal development of the wondrous language of the hand will come not from a "school of design" but from a "school of the new man" which will cause this language to spring forth spontaneously like water from an inexhaustible spring. To confer the gift of drawing we must create an eye that sees, a hand that obeys, a soul that feels; and in this task the whole life must cooperate. In this sense life itself is the only preparation for drawing. Once we have lived, the inner spark of vision does the rest.

Leave to man then this sublime gesture which transfers to the canvas the marks of creative divinity. Leave it free to develop from the very time when the tiny child takes a piece of chalk and reproduces a simple outline on the blackboard, when he sees a leaf and makes his first reproduction of it on the white page. Such a child is in

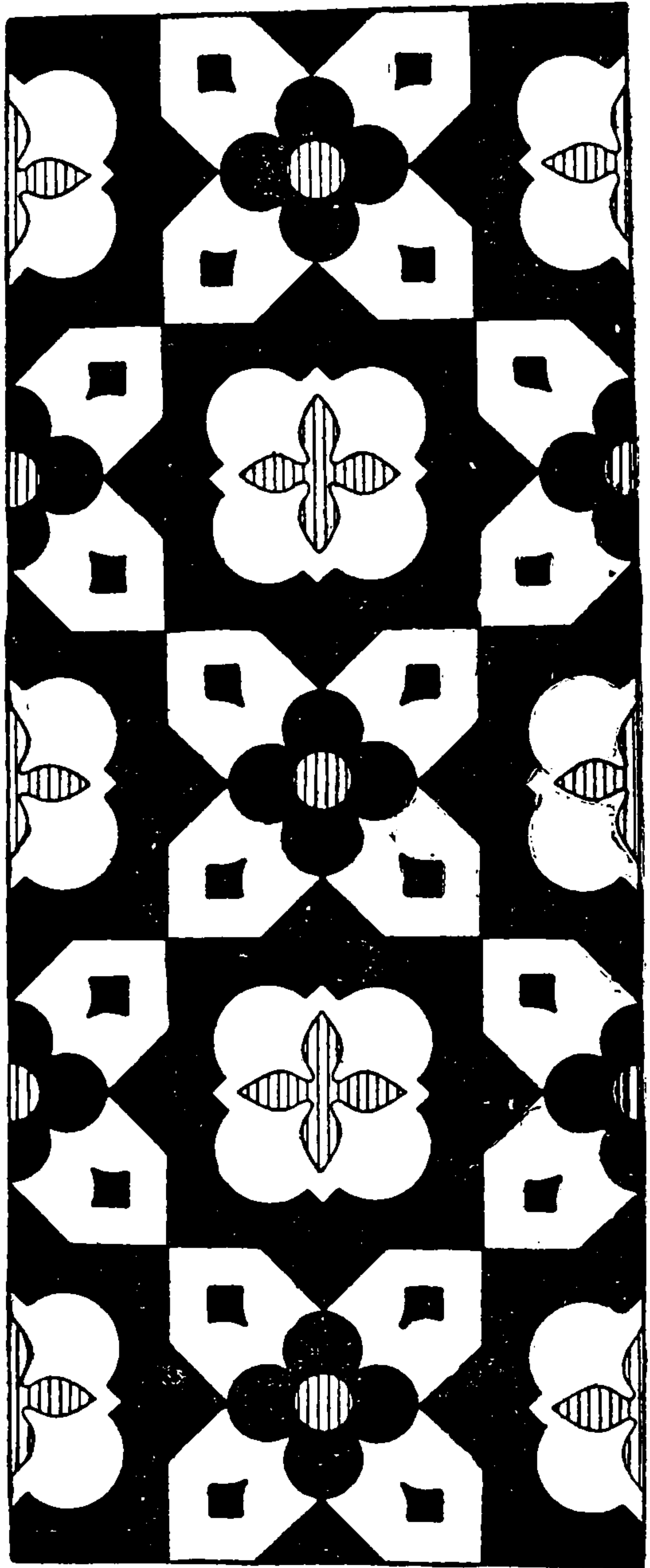
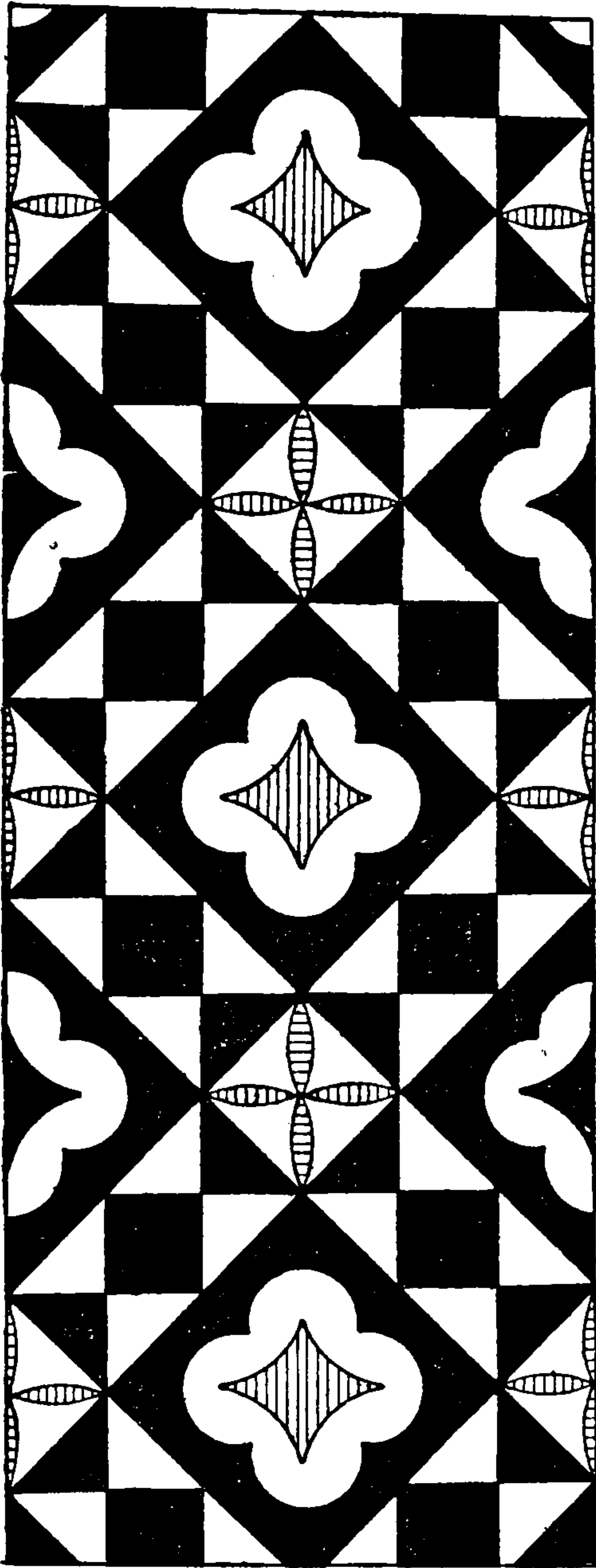

Designs formed by the use of the geometry squares, circles, and equilateral triangle, modified by free-hand drawing. In the design on the right the "flower" within the cross is made with compasses; the decorative detail in the arms of the cross and the circle in the center are free-hand. The design on the left is similar to a decoration in the Cathedral at Florence, in the windows round the apse.

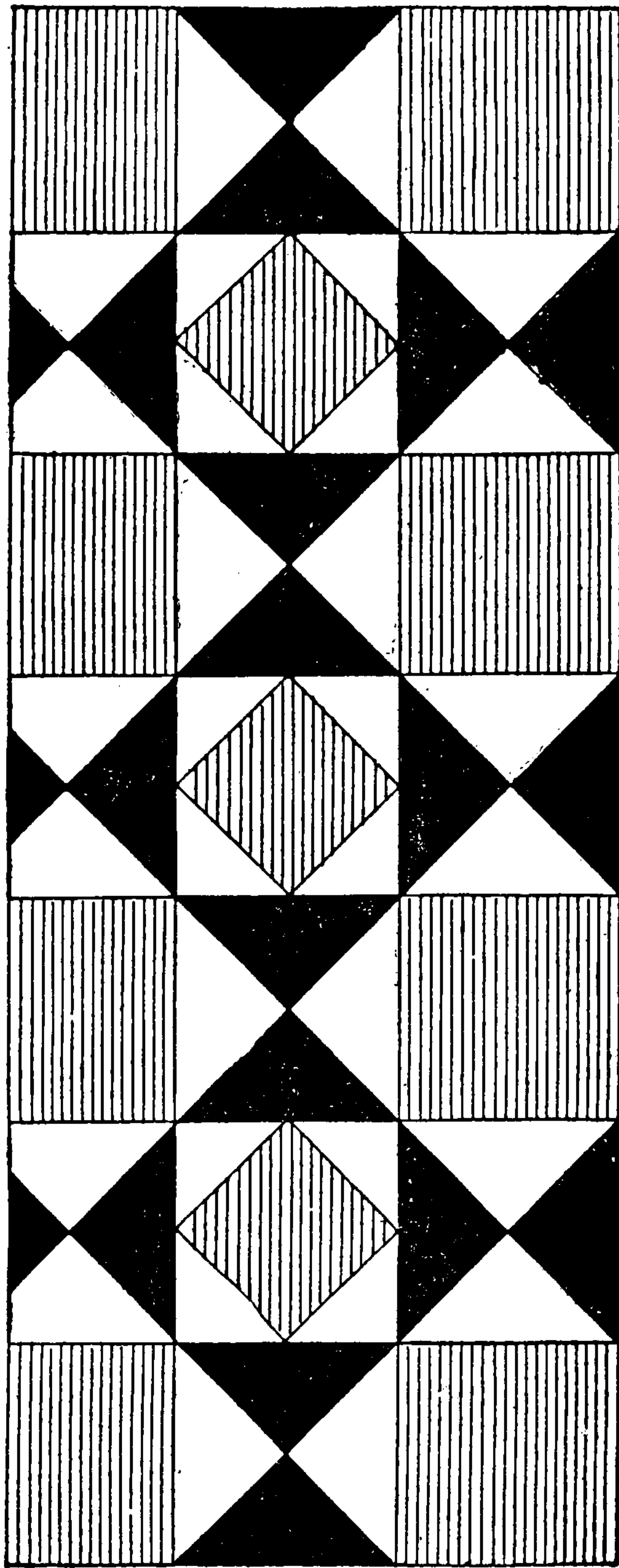
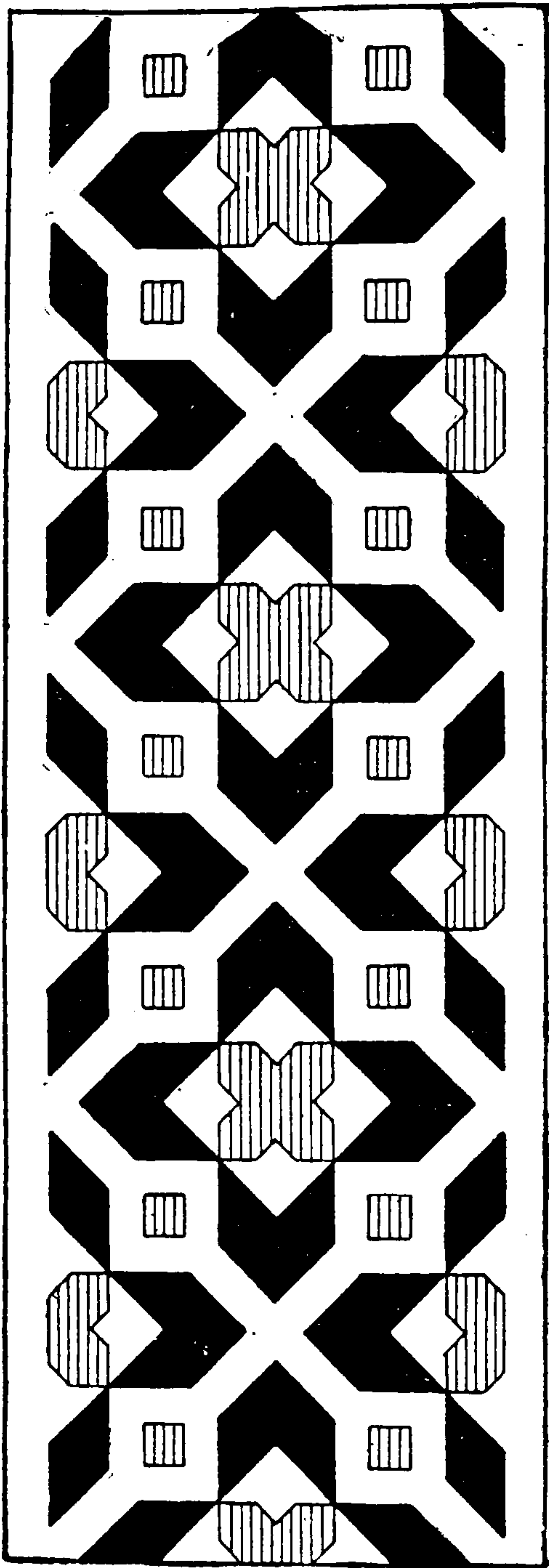

Decorations formed by the use of the geometry insets. That on the right is a copy of the design by Giotto shown below the picture of the Madonna in the Upper Church of St. Francis d'Assisi (Umbria).

THIS PAGE IS LOCKED TO FREE MEMBERS

Purchase full membership to immediately unlock this page

Know Your Bible

Forgotten Books' Full Membership provides unlimited access to more than 28,000 volumes of Christian literature for \$8.99/month

**HOLY
BIBLE**

Continue

*Fair use policy applies

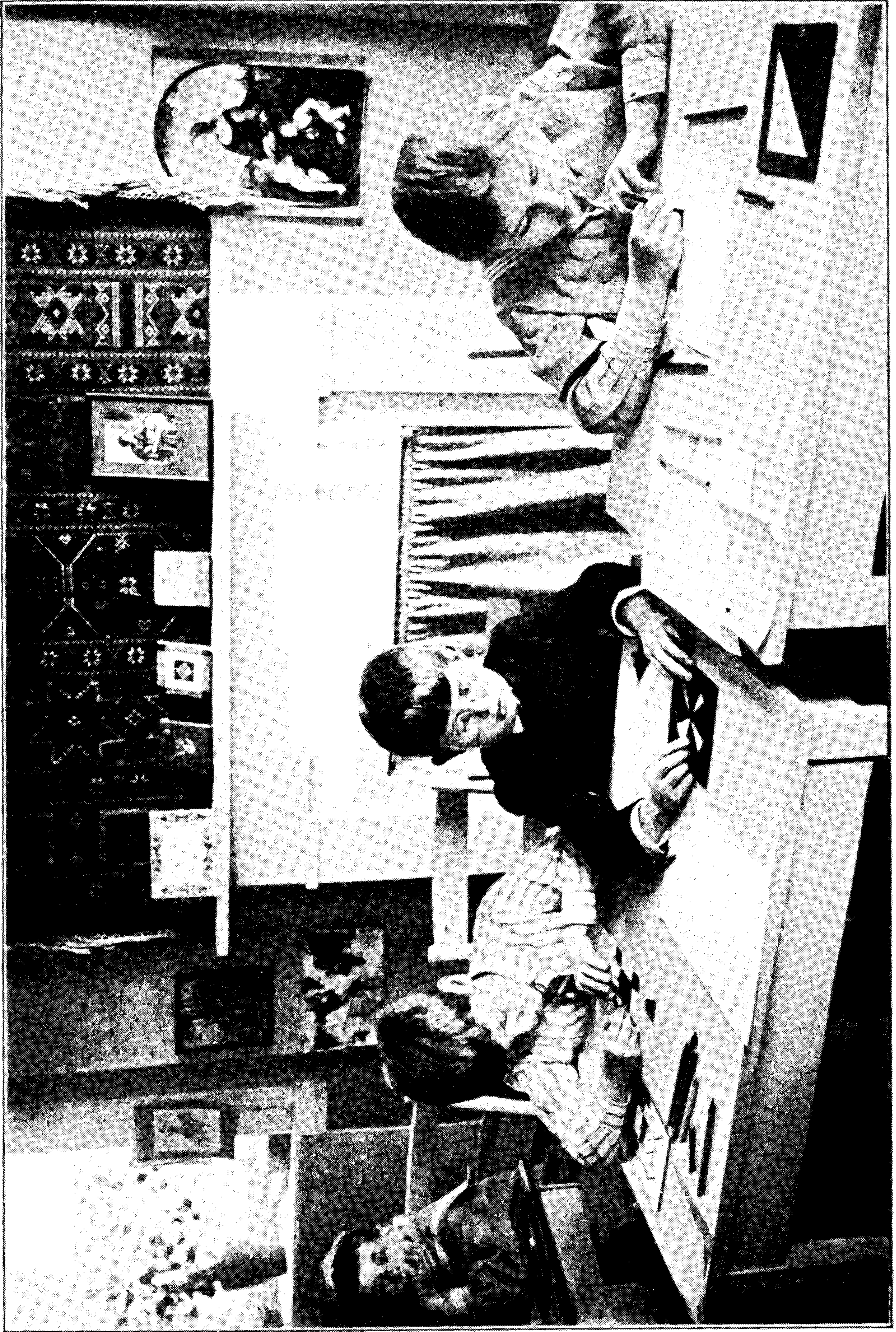

Making decorative designs with the aid of geometric insets. (The Washington Montessori School,

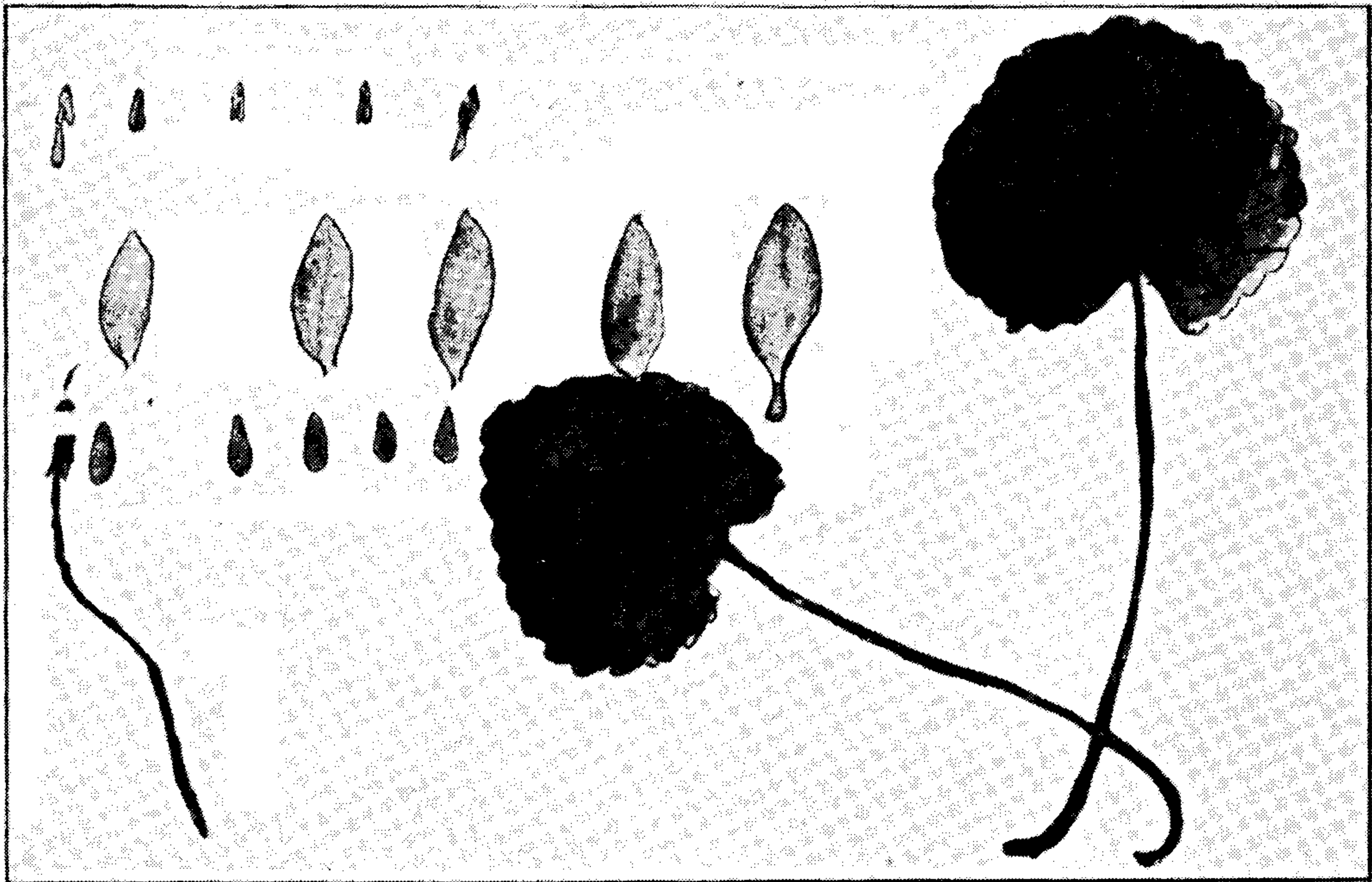
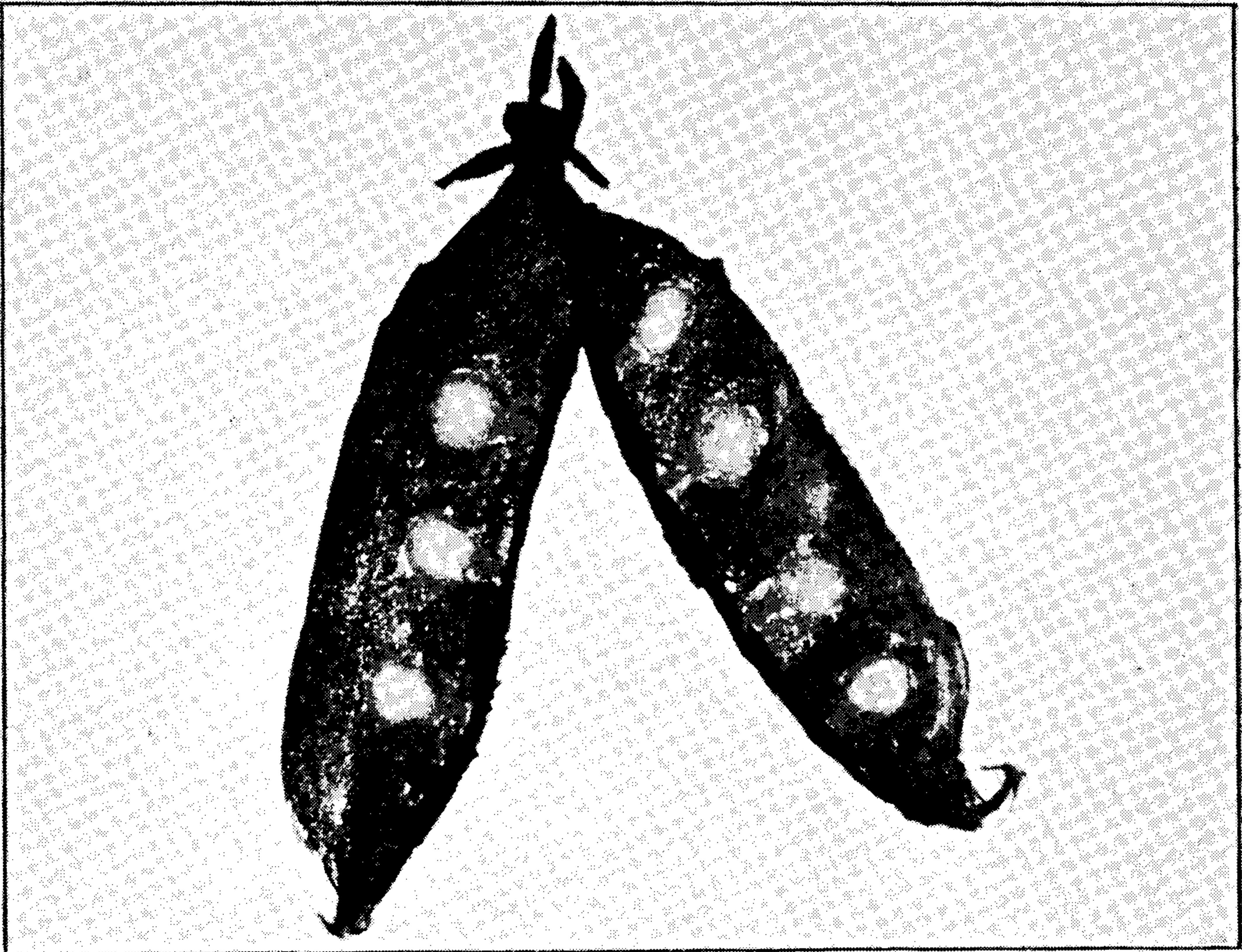

Water-color paintings from nature, showing spontaneous expression resulting from work in natural science.

of color and in reproducing them with striking accuracy.

The study of natural science proved to be a great help in drawing. Once I tried to show some children how a flower should be dissected, and for this purpose I provided all the necessary instruments: the botanist's needle, pincers, thin glass plates, etc., just as is done at the university for the experiments in natural science. My only aim was to see whether the preparations which university students make for botanical anatomy were in any way adaptable to the needs of little children. Even at the time when I studied in the botanical laboratory at the university I felt that these exercises in the preparation of material might be put to such use. Students know how difficult it is to prepare a stem, a stamen, an epithelium, for dissection, and how only with difficulty the hand, accustomed for years exclusively to writing, adapts itself to this delicate work. Seeing how skilful our children were with their little hands I decided to give them a complete scientific outfit and to test by experiment whether the child mind and the characteristic manual dexterity shown by children were not more adapted to such labors than the mind and hand of a nineteen-year-old student.

My suspicion proved correct. The children with the keenest interest dissected a section of the violet with remarkable accuracy, and they quickly learned to use all the instruments. But my greatest surprise was to find that they did not despise or throw away the dissected parts, as we older students used to do. With great care they placed them all in attractive order on a piece of white paper, as if they had in mind some secret purpose. Then with great joy they began to draw them; and they were accurate, skilled, tireless, and patient, as they are in

THIS PAGE IS LOCKED TO FREE MEMBERS

Purchase full membership to immediately unlock this page



HISTORY

Tens of thousands of important historical sources, many previously unobtainable, are now available for the first time with a Forgotten Books Full Membership.

Unlimited Access
\$8.99/month

Continue

*Fair usage policy applies

the new work, describing even the less noticeable details of the little violet.

These two expressions — drawing and composition — were the spontaneous manifestations of their happy entrance into the realms of science.

Encouraged by this great success, I took some simple microscopes to school. The children began to observe the pollen and even some of the membrane coverings of the flower. By themselves they made some splendid cross-sections of the stems, which they studied most attentively.

They “drew everything they saw.” Drawing seemed to be the natural complement of their observation work.

In this way the children learned to draw and paint *without a drawing teacher*. They produced works which, in geometric designs as well as in studies from life, were considered far above the average drawings of children.

PART VI

MUSIC

THIS PAGE IS LOCKED TO FREE MEMBERS

Purchase full membership to immediately unlock this page

Know Your Bible

Forgotten Books'
Full Membership
provides unlimited
access to more than
28,000 volumes of
Christian literature for
\$8.99/month

**HOLY
BIBLE**

Continue

*Fair use policy applies

I

THE SCALE

Since the publication of my first volume on the education of small children, considerable progress has been made in the matter of musical education. Miss Maccheroni, who came to Rome to work with me on experiments looking to the continuation of the methods used with primary classes, was successful in establishing a number of tests which constituted our first steps into this important field of education. We are under great obligations to the Tronci firm of Pistoja, which took charge of the manufacture of materials and gave us the most sympathetic cooperation.

We had already prepared at the time of that first publication an equipment of bells to be used in training the ear to perceive differences between musical sounds. The methods of using this material were considerably modified and perfected again after the publication of my *Own Handbook* (New York, Stokes, 1914), in which for the first time appeared a treatise on musical method. The foundation of the system consists of a series of bells representing the whole tones and semi-tones of one octave. The material follows the general characteristics of that used in the sensorial method, that is, the objects differ from each other in one and only one quality, the one which concerns the stimulation of the sense under education. The bells, for instance, must be *apparently identical* in

dimensions, shape, etc., but they must *produce different sounds*. The basic exercise is to have the child recognize "identities." He must pair off the bells which give the same sound.

The bell system is constructed as follows: We have a very simple support, made of wood (of course any other material might be used) 115 cm. long and 25 cm. wide. On this the bells rest. The board is wide enough to hold

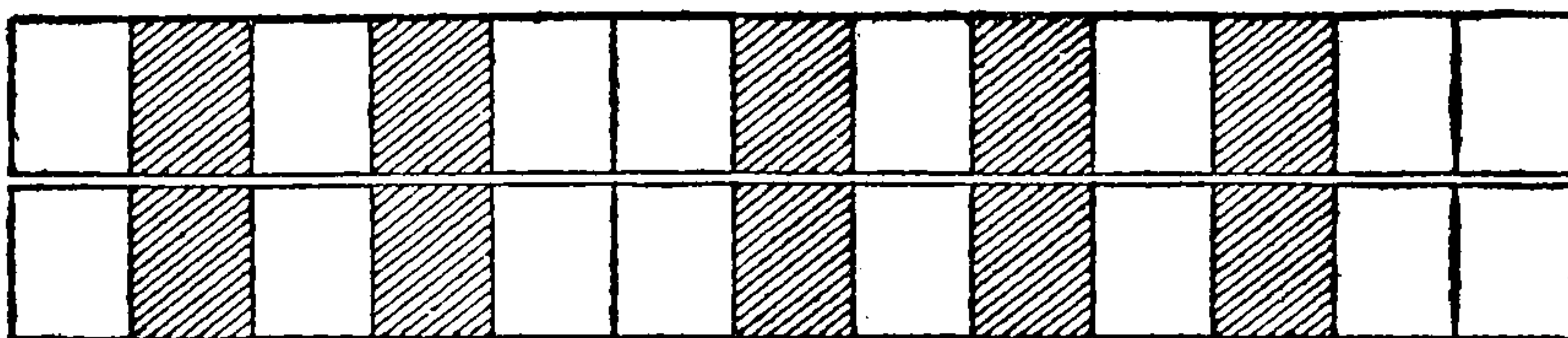

two bells placed lengthwise and end to end across it. The board is marked off into black and white spaces, each wide enough to hold one bell. The white spaces represent whole tones, the black spaces semi-tones. Though the apparent purpose of this board is to serve as a support, it is in reality a *measure*, since it indicates the regular position of the notes in the simple diatonic scale. The combination of white and black rectangles indicates the interval between the various notes in the scale: in other words, a semi-tone between the third and fourth and between the seventh and eighth, and a whole tone between the others. Bells showing the value of each rectangle are fixed in proper order in the upper portion of the support. These bells are not all of the same size, but vary in dimension regularly from the bottom to the top of the scale. This permits considerable saving in manufacture; for, to get a different sound from bells of the same size, different thicknesses are required, and this entails more labor for construction and consequently

greater cost. But in addition the child here sees a material variation corresponding to the differences in quality of sound. On the other hand, the other bells on which the child is to perform his critical exercises are of *identical dimensions*.

In the exercise the child strikes with a small mallet one of the bells fixed on the support. Then, from among the others scattered at random on the table, he finds one which gives the same sound and places it on the board in front of the fixed bell corresponding to it. In the most elementary exercises, only the whole tone bells corresponding to the white spaces are used. Later, the semitones are brought in. This first exercise in sense perception corresponds to the pairing practised in other sensory exercises (color, touch, etc.) The next step is for the child to distinguish differences, and at the same time, gradations of stimuli (like the exercises with the color charts, hearing, etc.) In this case the child mixes at random the eight bells, all of the same size, which give the whole tones of the scale. He is to find *do*, then *re*, and so on through the octave one note after the other, placing the bells in order in their proper places. Nomenclature is taught step by step as in the other sensorial exercises. To familiarize the child with the names, *do, re, mi, fa, sol, la, si*, we use small round disks, the circular form serving to suggest the head of the written note. On each disk the name of the note is written. The disks are to be placed on the bases of the bells that correspond to them. The exercises in naming the notes may be begun with the fixed bells, in order (with children who already know how to read) to associate the sounds with their names in the first exercise of pairing. Later, when the child comes to the exercise of putting

THIS PAGE IS LOCKED TO FREE MEMBERS

Purchase full membership to immediately unlock this page



HISTORY

Tens of thousands of important historical sources, many previously unobtainable, are now available for the first time with a Forgotten Books Full Membership.

Unlimited Access
\$8.99/month

Continue

*Fair usage policy applies

tual performance is the only guide to the revelation of particular aptitude, of personal calling.

When one of the larger children spreads on the table the eight bells of similar size to make up the scale by ear, the little ones pick up a single bell, sometimes reaching out for it with the greatest eagerness. They beat it with the mallet for a long time, they feel of it, examining it carefully, making it ring more and more slowly. The older children take special interest in the pairing, often repeating the same exercise many times; but an unusual charm is found in the successive sounds of the eight bells when placed in order; in other words, in hearing the scale. Nennella, one of the children of the "Children's House" of Via Giusti, played the scale over two hundred times in succession, one hundred for the ascending scale and one hundred back again. The whole class is sometimes interested in listening, the children following with absolute silence the classic beauty of this succession of sounds. Another child, Mario, used to go to the very end of the table — as far away as possible, and resting his elbows on the table with his head in his hands, he would remain without stirring in the silence of the darkened room, showing his extraordinary interest in the exercise in every detail of demeanor and facial expression.

At a certain moment, interest in reproducing the note vocally appears. The children accompany the scale with their voices. They strive for the exact reproduction of the sound which the bell gives. Their voices become soft and musical in this exercise, showing nothing of that shrillness, so characteristic of children's voices in the usual popular songs. In the classes of Via Trionfale it happened that some children asked permission to accompany vocally the scale that a child was playing softly on

the bells. The interest taken in this exercise was of a higher order than that shown by children in the singing of songs. It was easy to see that songs with their capricious intervals between widely separated notes and calling for pronunciation of words, musical expression, differences in time, etc., are unadapted to the most elementary exercises in singing.

It was possible to test the absolute memory of the child for the different notes without any set exercise. After a long series of experiments in pairing, the children begin to make scales, using only one series of bells, and they repeat this exercise many times and in different ways. Sometimes, for instance, a child always looks for the lowest note, *do*, then for the next above it, *re*, etc. Again, a child will take any bell at random, looking next for the note immediately above or immediately below, and so on. It also happens that on picking up some bell or other, the child will exclaim on hearing its sound, this is *mi*, this is *do*, and so on. One child had made a splendid demonstration of the use of the bells before her Majesty, the Queen Mother. This was in the month of May. Although he had had no further access to the materials in his "Children's House" of Via Giusti, in the November following he was asked to use some musical pipes,¹ which he had hardly seen before, and which happened to be in great disorder since they had just arrived from the factory. There were sixteen pipes mixed at random, comprising a double diatonic scale. He took one of the pipes, struck it and said, "This is *si*," and immediately hung it on the appropriate hook of the support. On ringing the next one, he said, this is *mi*, and again put the pipe

¹ The pipes are an equipment parallel to the bells. They are to be recommended for schools, which can afford a more sumptuous outlay.

in the right place. So he went on and arranged the sixteen pipes in accurate order on the two parallel frames. He had had a good deal of exercise during the preceding year and had preserved an absolutely accurate memory of the notes.

As is the case with colors, geometrical shapes, etc., the children begin at this point to explore the environment. One will come to the teacher at the piano and say, striking a key, "This is *stee*," meaning that the note corresponds to the first syllable of the first word in some song he knows (Stella, Stellina). It happens that the key struck by the child is a *do*, the very note corresponding to the syllable *ste* in the song. We had many touching examples of this musical exploration of the environment.

THIS PAGE IS LOCKED TO FREE MEMBERS

Purchase full membership to immediately unlock this page

Know Your Bible

Forgotten Books'
Full Membership
provides unlimited
access to more than
28,000 volumes of
Christian literature for
\$8.99/month

**HOLY
BIBLE**

Continue

*Fair use policy applies

In the semi-tone spaces black counters are to be placed. At a later stage of this exercise the staff is represented by a wooden board similar to the one described above, but without the indentures. The child has at his disposal a great many disks with the notes written out in full on one face. He can arrange thirty or forty of these disks at random on the board, keeping them, however, in their

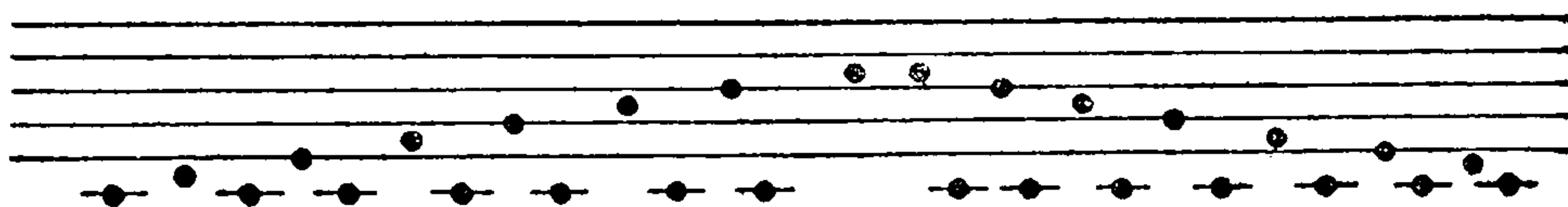
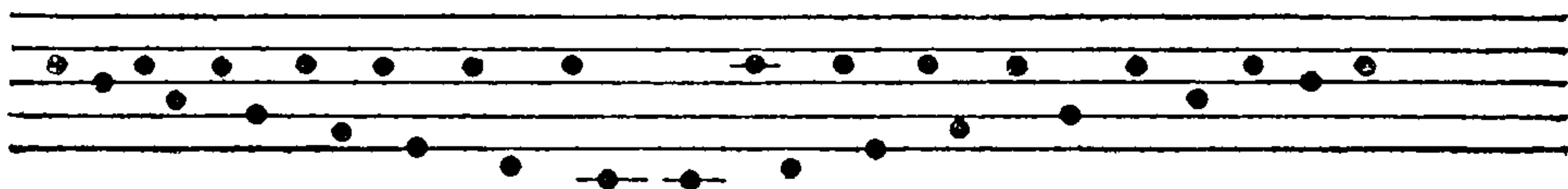
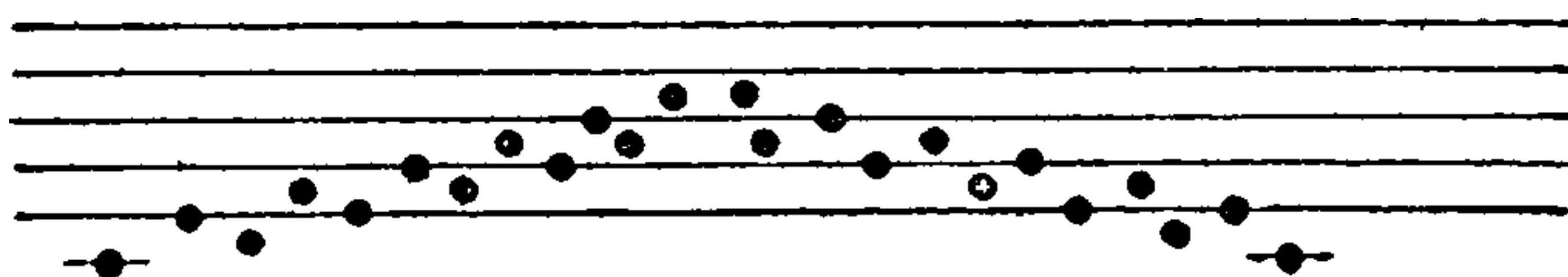
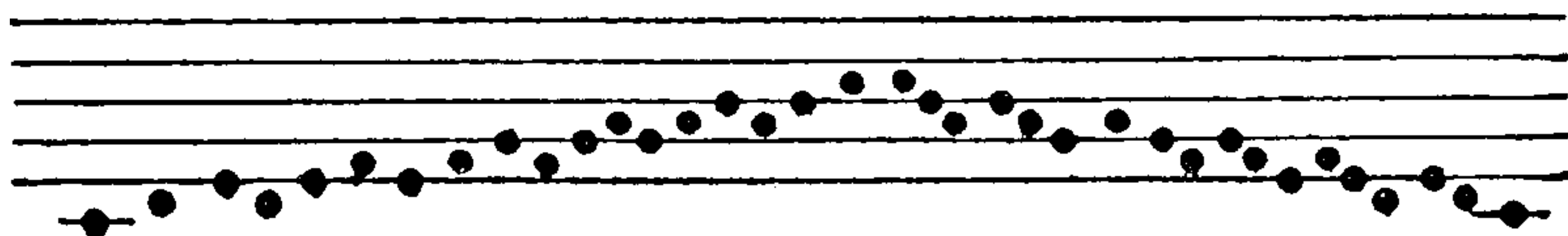

places according to the names of the notes; but each time the surface showing the name of the note should be placed downward on the board, so that on the line only disks without names are visible. When a child has finished this exercise, he is to turn the disks over without disarranging them and so determine from their names whether he has placed them properly. All the disks on a given line or in a given space should have the same names.

Should any doubt arise as to the proper place of a note, the other board with the numbered indentures can be used as a check.

When a child has reached this stage of development, he can practice reading the musical script, ringing the bells according to the notes he is interpreting. The musical staves are prepared on oblong cards about seventeen centimeters broad. The notes are about two centimeters in diameter. The cards are variously colored — blue, violet, yellow, red.

The next step is for the children to write notes themselves. For this purpose we have prepared little sheets which can be bound together into a book or album.

We offer also a few songs employing two or three notes so simple in character that the child can make them out by ear on his bells. When, after some practise, he is certain he can copy the song, he writes the notes on his staff and so becomes the editor of his own music.

TREBLE AND BASS CLEFS

Arrangement of the notes in the form of a rhombus: All the exercises thus far have been in reference to the higher *clef*. However, no representation of this key has as yet been given the child. His first task is to learn the relative position of the notes on the two staves. To supply this want, following the system of the Musical Conservatory of Milan, we have adopted the double staff.

A sheet on which the child writes his own music.

THIS PAGE IS LOCKED TO FREE MEMBERS

Purchase full membership to immediately unlock this page



HISTORY

Tens of thousands of important historical sources, many previously unobtainable, are now available for the first time with a Forgotten Books Full Membership.

Unlimited Access
\$8.99/month

Continue

*Fair usage policy applies

The broken line (p. 328) indicates the position of *do*, the point of departure for the scale. In fact, as the notes pass from line to space and space to line, they form the natural series:

do, re, mi, fa, sol, la, si, do.

The same situation develops as they go down the scale:

do, si, la, sol, fa, mi, re, do.

When the position of *do* has been determined, the other notes above and below it are easily found. From the *do* on the left the child can find his way to the *do* on the

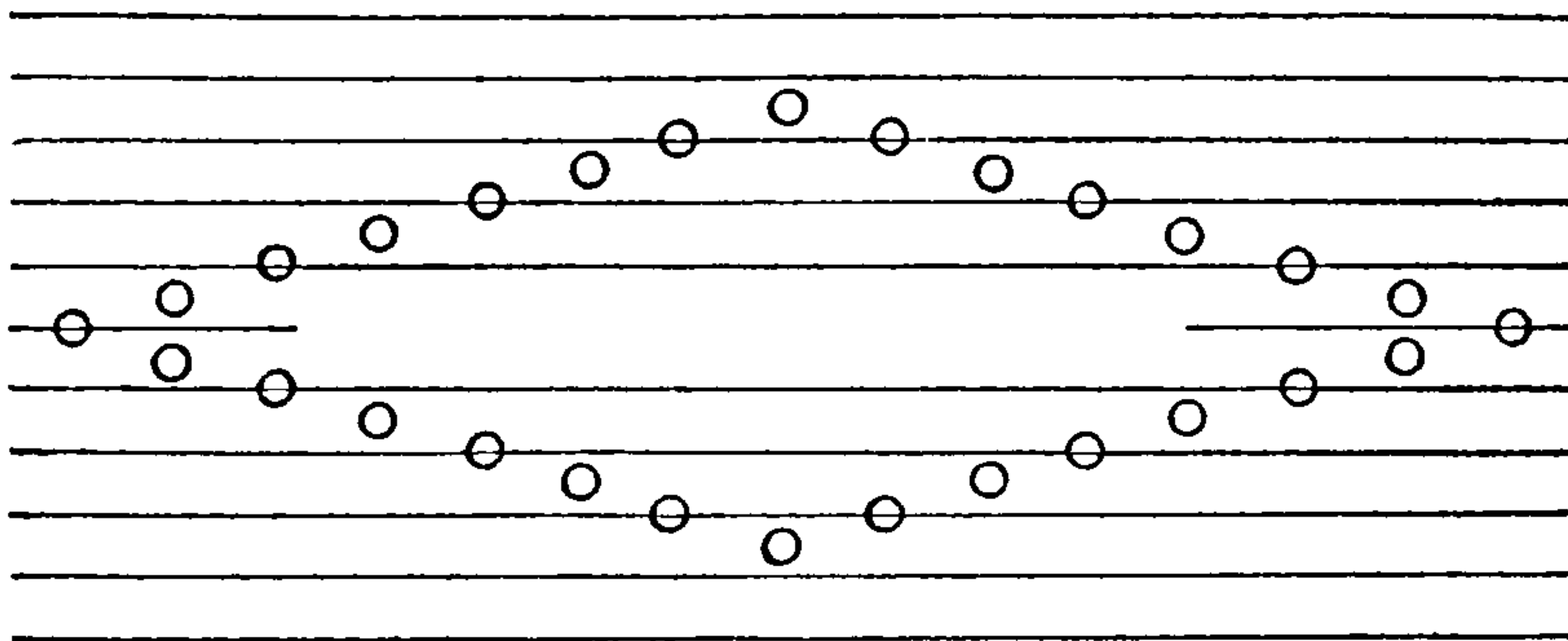

next octave higher and come down again. Likewise from the same point on the right (*do*) he can go down to the *do* of the lower octave and then go up the scale again. When these notes are represented on the combined staves with the counters, the resulting design is a rhombus.

Separating the two staves, the arrangement of the notes in the higher and lower key (the C scale and bass) becomes apparent and the different significance of the two series can be emphasized by placing to the left of the staff the two clef signs, which have been prepared as special portions of our material.

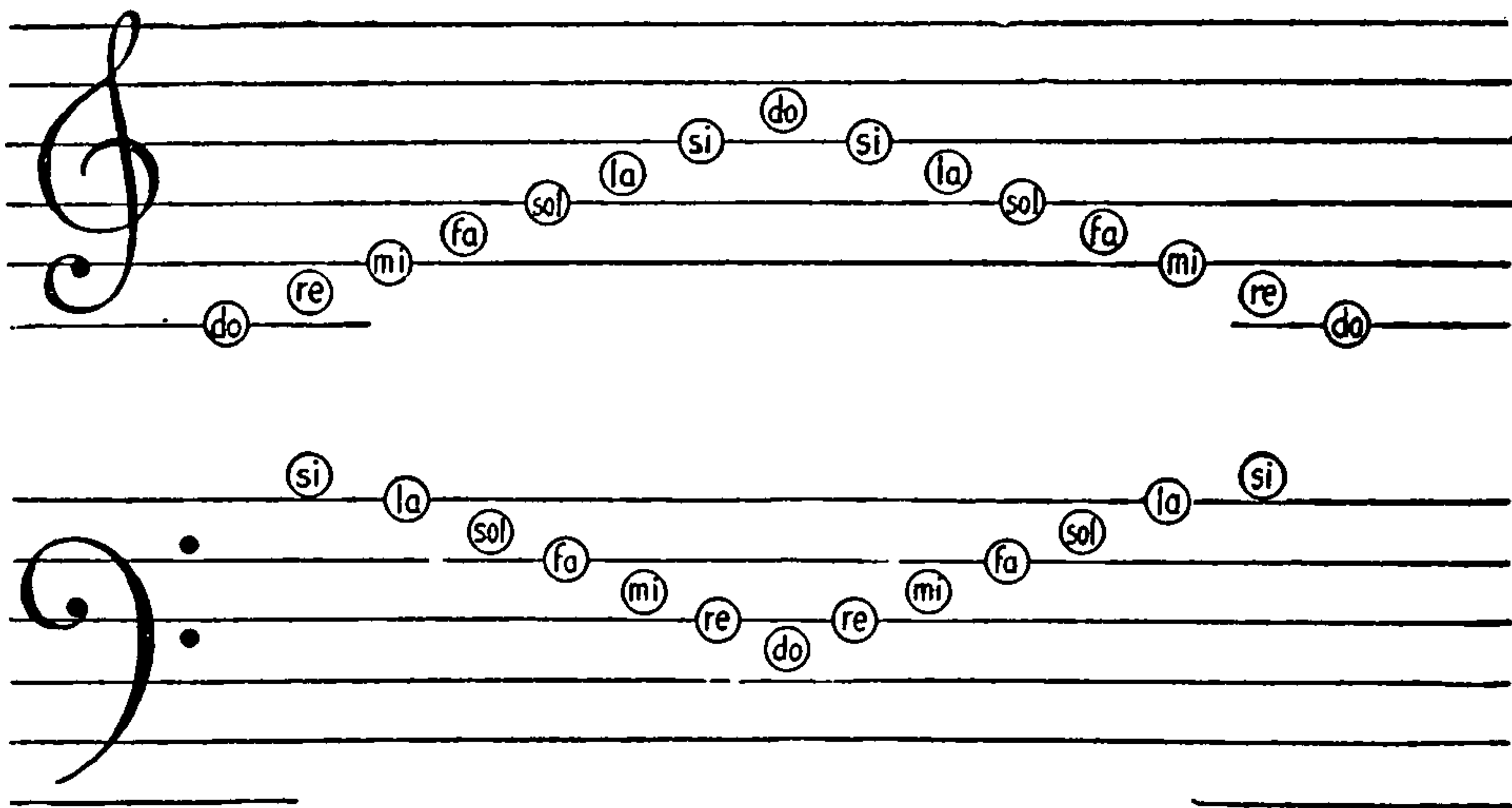

In this way the children have learned the scale in *do major* in the two keys. The arrangement of the black and white spaces puts them in a position to recognize these notes even on the piano. Our material, in fact, includes a diminutive keyboard where the keys are small enough to fit the size of a child's hand. It can be used as an exercise for the finger muscles. As each key is touched it raises a hammer marked with the name of the note struck, which the child can see through a glass. Thus while the child is practising his finger movements, he fixes his acquaintance with the arrangement of the notes on the keyboard. This small piano makes no noise. However, a sort of organ-pipe mechanism can be fitted on above the hammers in such a way that each stroke, as the hammer rises, connects with a reed which gives a corresponding sound.

All the exercises thus far have been based upon sensory experience as the point of departure. The child's ear has recognized the fundamental sounds and initiated him into real musical education. All the rest, such as the music writing, etc., is *not music*.

III

THE MAJOR SCALES

We have developed additional material for the teaching of the scales. Here we show a chart somewhat suggesting the arrangement of the bell material used in the first exercises. That is, the relative intervals between the various notes of the scale are clearly indicated. The *scale* is, in fact, a series of eight sounds, the intervals between each being as indicated by the black marks in the design: whole tone, whole tone, semi-tone, whole tone, whole tone, whole tone, semi-tone.

In the *do major* scale the intervals are indicated as follows: a whole tone between *do* and *re*; *re* and *mi*; *fa* and *sol*; *sol* and *la*; *la* and *si*; and a semi tone between *mi* and *fa* and *si* and *do*. If, however, instead of beginning with *do*, the scale starts from some other note, the mutual intervals characterizing the scale remain unchanged. It is as though the whole scale with its characteristic construction as regards tone differences were moved along. Accordingly, as our plate shows, under the figure of the two octaves there is another figure. This latter is a movable piece of cardboard which shows the construction of the octave in black and white. This movable card is fastened to the large chart by a ribbon. Supposing now we slide this movable piece, as indicated in the figure, to the level of *mi*. The intervals between the tones of the *mi* scale are the same as in all the other

THIS PAGE IS LOCKED TO FREE MEMBERS

Purchase full membership to immediately unlock this page

Know Your Bible

Forgotten Books'
Full Membership
provides unlimited
access to more than
28,000 volumes of
Christian literature for
\$8.99/month

**HOLY
BIBLE**

Continue

*Fair use policy applies

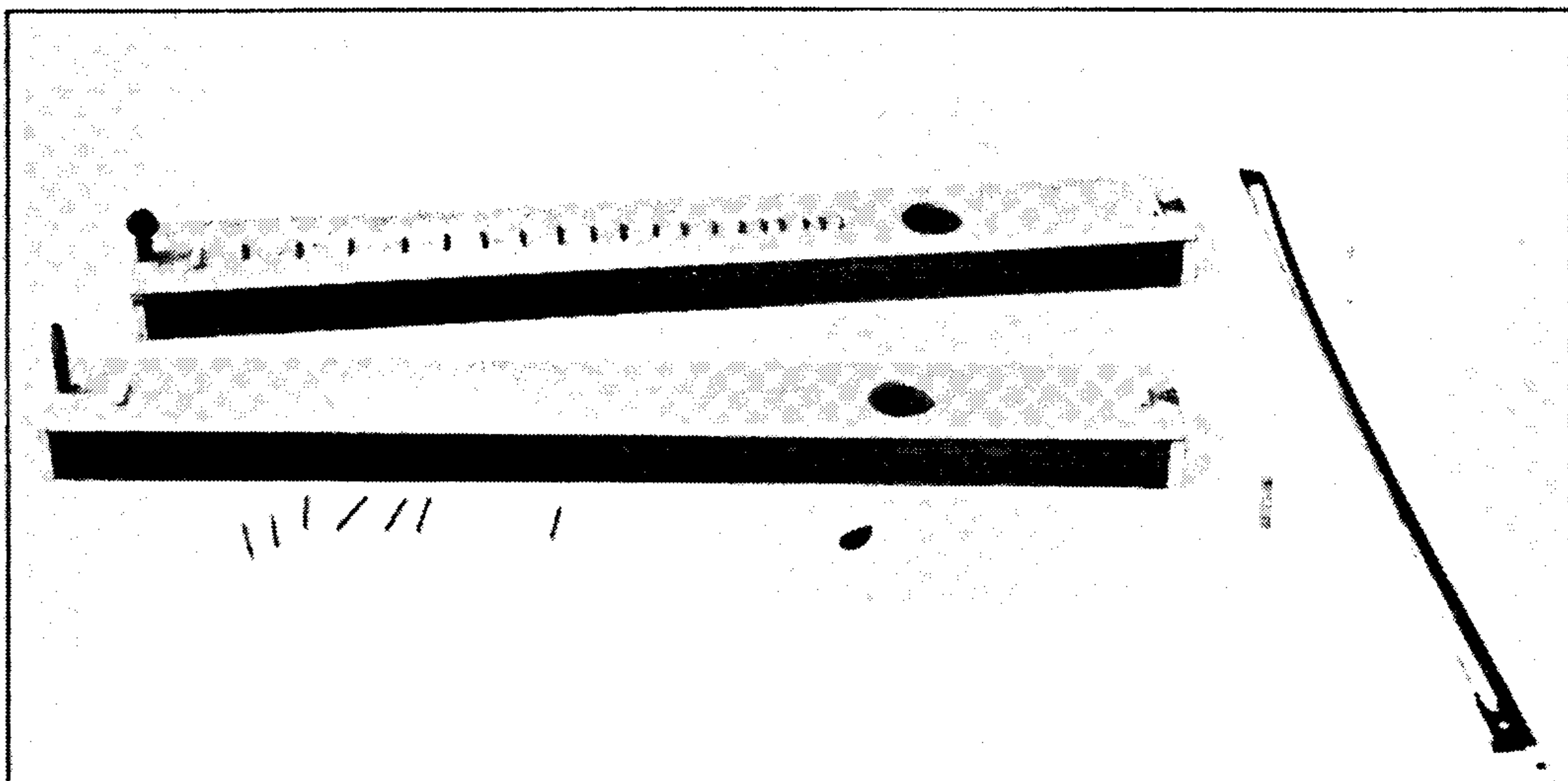

The monochord. In the first instrument the notes are indicated by frets. On the monochord in the foreground the child places the frets as he discovers the notes by drawing the bow across the string.

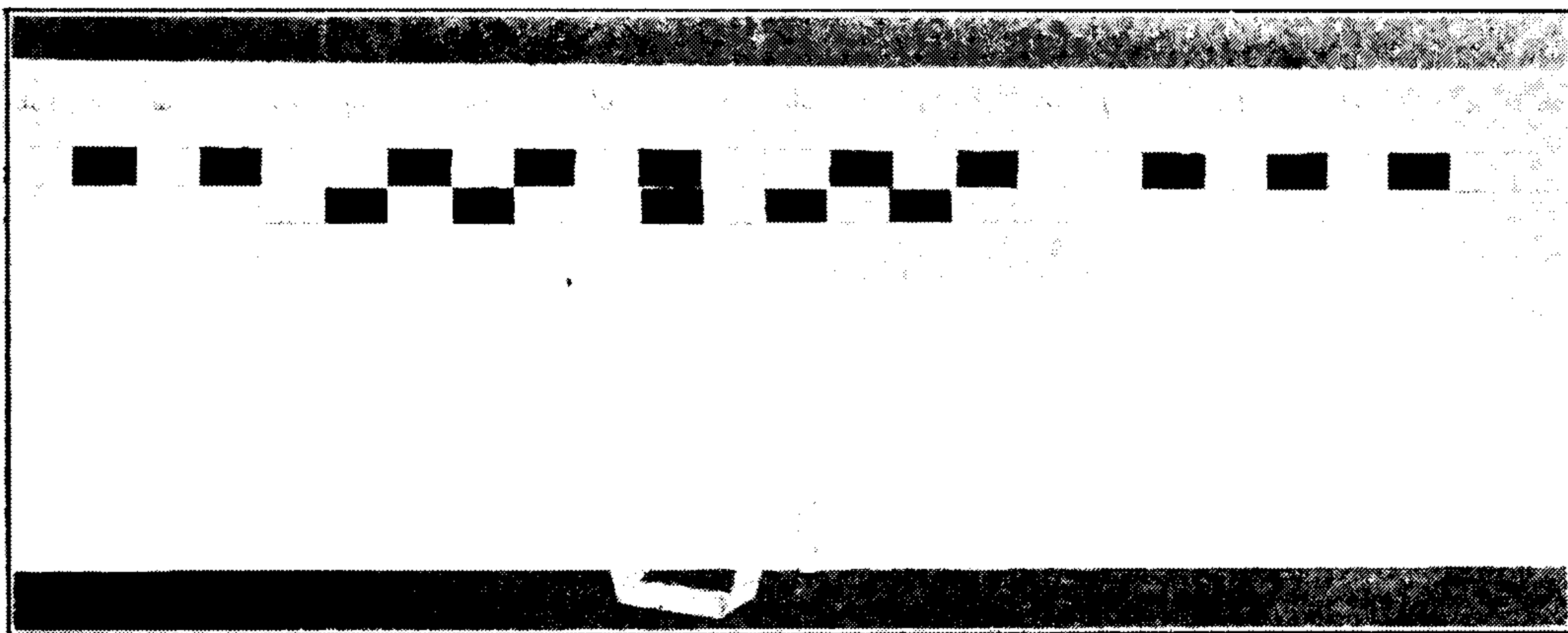

Material for indicating the intervals of the major scale and its transposition from one key to another.

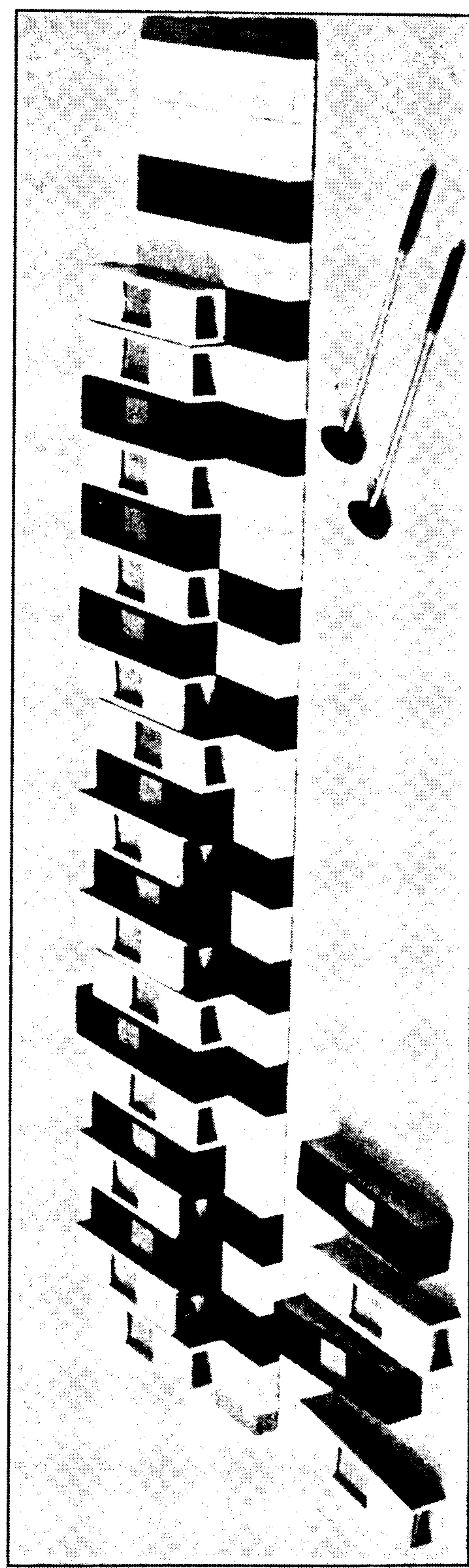
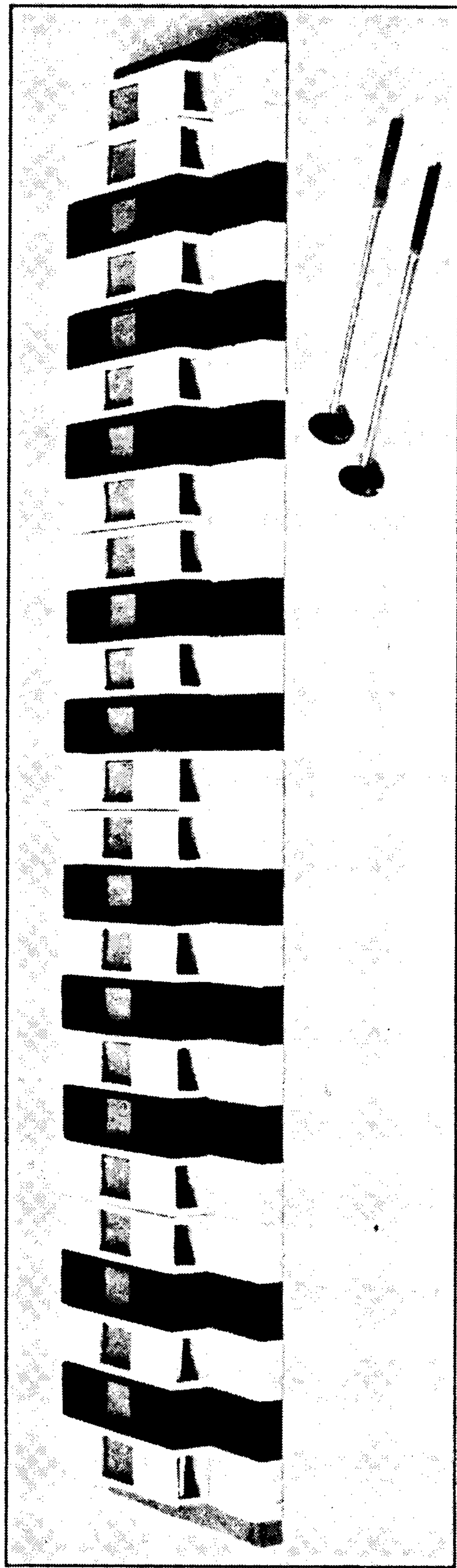

The upper cut shows the music bars arranged for the scale of C major. The lower cut shows the transposition of the scale, preserving, however, the same intervals.

matter how far the group of prisms is moved, the scale can be obtained by striking all the prisms corresponding to the white spaces on the wooden form.

For instance, let us take away the two first prisms, *do* and *do diesis* on the left, and push the whole group of prisms from right to left until *re* reaches the point formerly occupied by *do*. If, now, we strike the plates which correspond to the notes of the major scale, we obtain the major scale in *re*. On examining the notes which make up this scale, we find: *re, mi, fa diesis, sol, la, si, do diesis, re*.

This brief description will indicate how interesting this instrument is. It contains in very simple form and expresses in a clear and delightful way the fundamental principles of harmony. Its use can be made apparent to teachers by the three following tables.

As the children derive in this way all the possible scales, they should transfer them to their copy books, making use of all the symbols of musical notation. The copying of the scales should be developed progressively: first the scale with one *diesis*, next the scale with two, then the one with three *dieses*, etc. Fine opportunities for observation are here offered. A child may see for instance that a scale with two *dieses* has the same *diesis* which appeared in the preceding scale; a scale with three *dieses* has the two *dieses* of the preceding scales, and so on. The *dieses* recur at intervals of five notes.

Since in using the first material, by changing the third and sixth bell, the child was taught to recognize the harmonic minor scale, to construct it and listen to it, it is now an obviously simple matter for him to make up all the minor scales.

We have thus developed exercises which prepare for

THIS PAGE IS LOCKED TO FREE MEMBERS

Purchase full membership to immediately unlock this page



HISTORY

Tens of thousands of important historical sources, many previously unobtainable, are now available for the first time with a Forgotten Books Full Membership.

Unlimited Access
\$8.99/month

Continue

*Fair usage policy applies

With one plate removed. Scale of D \flat .

Scale of C \sharp .

With three plates removed Scale of E \flat .

With six plates removed. Scale of G \flat .

Scale of F \sharp .

With eight plates removed. Scale of A \flat .

With ten plates removed. Scale of B \flat .

Here is a specimen of key transposition:

1		2		3	4		5		6		7	8
1		2	3		4		5	6			7	8

At this point children usually develop great keenness for producing sounds and scales on all kinds of instruments (stringed instruments, wind instruments, etc.)

One of the instruments which brings the child to producing and recognizing notes is the *monochord*. It is a simple, resonant box with one string. The first

Scale of C.

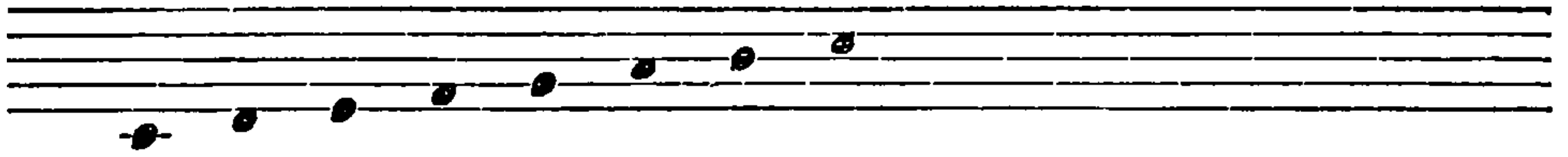

Scale with sharps.

Scale with flats.

exercise is in tuning. The string is made to correspond with one of the resonant prisms (*do*). This is made possible by a key with which the string can be loosened or tightened. The child may now be taught to handle the violin bow or mandolin plectrum, or he may be instructed in the finger thrumming used for the harp or banjo. On one of our monochords, the notes are indicated by fixed transversal frets, the name of each note being printed in the proper space. These notes are, however, not written on the other monochord, where the child must learn to discover by ear the proper distances at

which the notes are produced. In this case the child has at his disposal movable frets with which he can indicate the points he has discovered as producing a given note. These frets should be left in position by the child to serve as a check on his work. The children have shown considerable interest also in little pitchpipes, which give very pleasing tones.

.

Thus in composing the scales and in listening to them the child performs real exercises in musical education. A given melody in the major scale is repeated in various keys. In listening to it carefully, in repeating it, in observing the notes which make it up, the child has an

C Pitch.



D Pitch.

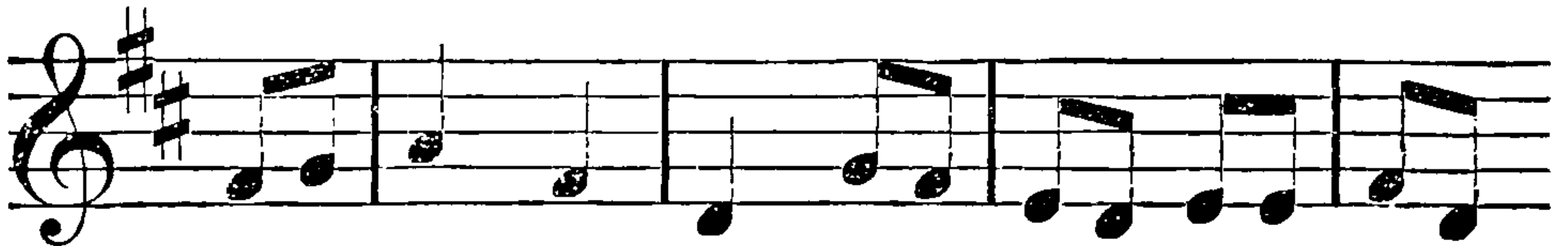

E Pitch.

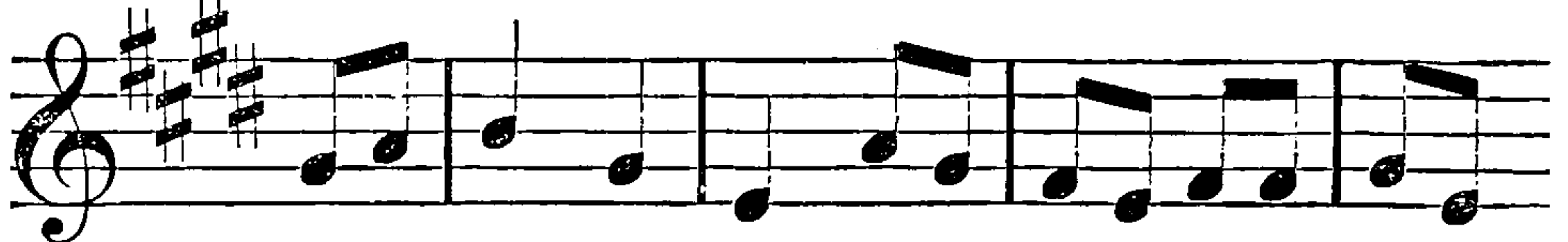

F Pitch.



THIS PAGE IS LOCKED TO FREE MEMBERS

Purchase full membership to immediately unlock this page

Know Your Bible

Forgotten Books'
Full Membership
provides unlimited
access to more than
28,000 volumes of
Christian literature for
\$8.99/month

**HOLY
BIBLE**

Continue

*Fair use policy applies

IV

EXERCISES IN RHYTHM

One of our most successful exercises has proved to be that originally conceived as a help in teaching children to walk, viz., "walking the line." It will be remembered that among the exercises in motor education used at the outset of our method, appeared that of walking with one foot in front of the other on a line drawn on the floor, much as do tight-rope-walking acrobats. The purpose of this exercise was to stabilize equilibrium, to teach erect carriage and to make movement freer and more certain.

Miss Maccheroni began her exercises in rhythm by accompanying this walking of the children with piano music. In fact, the sound of the piano came to be the call signal for the children to take up this exercise. The teacher starts to play and immediately the children come of their own accord, and almost without exception, to take up their positions on the line. At the very beginning the music seems to be purely a signal, at best a pleasant accompaniment to the motor exercise. There is no apparent adaptation of the child's movements to the musical rhythm. However, as the same measure is repeated for a considerable period, the rudiments of this adaptation begin to appear. One of the children begins to keep step with the rhythm of the music. Individual differences in adaptation persist for some time; but if the same musical rhythm is kept up, almost all the chil-

dren finally become sensible to it. In fact, these little people begin to develop general attitudes of body, in relation to the music, which are of the greatest interest. First of all, the children change their gait according to the music: the light walk, the war-like march, the run, develop on the impulse of the rhythmic movement. It is not that the teacher "teaches" the child to change his walk according to the music: the phenomenon arises of its own accord. The child begins to interpret the rhythm by moving in harmony with it. But to obtain this result the teacher must play perfectly, carefully noting all the details of musical punctuation. The creation of musical feeling in the children depends upon the teacher's own feeling and the rigorous accuracy of her own execution.

It will be useful to give here a few details on the execution of these first rhythmic exercises. The children begin, as we have said, by learning to walk on the line. They develop a passion for walking on that line, yielding to a fascination which grown-up people cannot conceive. They seem to put their whole souls into it. This is the moment for the teacher to sit down at the piano and without saying anything to play the first melody in our series. The children smile, they look at the piano and continue to walk, becoming more and more concentrated on what they are doing. The melody acts as a persuading voice; the children begin to consider the time of the music and little by little their tiny feet begin to strike the line in step with it. Some of our three-year-olders begin to keep step as early as the first or second trial. After a very few attempts a whole class of forty children will be walking in time. We must warn against the error of playing with special emphasis on the measure;

in other words, of striking more loudly than is required the note (thesis) which marks the inception of the rhythmic period. The teacher should be careful simply to bring out all the expression that the melody requires. She may be sure that the rhythmic cadence will become apparent from the tune itself. The playing of one note more loudly than the others, thus to emphasize the rhythmic accent (thesis), is to deprive the selection of all its value as melody and therefore of its power to cause the motory action corresponding to rhythm. It is necessary to play accurately and with feeling, giving an interpretation as real as possible. We get thus a "musical time" which, as every one knows, is not the "mechanical time" of the metronome. If it is certainly absurd to play a *Nocturne* of Chopin on the metronome, it is hardly less absurd and certainly quite as disagreeable to play a piece of dance music on that instrument. Even those people who have a great aptitude for feeling "time" and who play with special attention to exactness of measure, know that they cannot follow the metronome without positive discomfort. Children feel the rhythm of a piece of music if it is played with *musical feeling*; and not only do they follow the time with their footsteps, but, as the rhythmic periods vary, they adapt the whole attitude of their bodies to the melodic period, which is developed around the beats constituting the rhythm as around points of support. There is a vast difference between this exercise and that of having children march to the clapping of hands or to the time of *one, two, three*, etc., counted in a tone of command.

A child of ten years was dancing to the music of a Chopin waltz played with most generous concessions to the different colorations indicated in the text. She put

THIS PAGE IS LOCKED TO FREE MEMBERS

Purchase full membership to immediately unlock this page



HISTORY

Tens of thousands of important historical sources, many previously unobtainable, are now available for the first time with a Forgotten Books Full Membership.

Unlimited Access
\$8.99/month

Continue

*Fair usage policy applies

Beppino, a little boy of three, used to keep time with the extended forefinger of his right hand. The music was a song in two parts repeated alternately, the one in *legato* and the other in *staccato*; with the *legato* he used a uniform regular movement; he followed the *staccato* with sudden spasmodic beats.

To-day forty children may be seen walking as softly as possible during a tune played *pianissimo*. These same children on the day when they first heard the *piano* kept calling to the teacher "play louder; we can't hear" and yet at that time the teacher was playing not *pianissimo*, but *mezzo forte*!

At first the children interested in the first tune are deaf to any other. The children in the St. Barnaba School in Milan got in step with the first tune. They did not notice that the teacher had changed to the second and kept their step so well that when the first tune was resumed, the teacher found them in perfect time, while on the faces of the children appeared a smile of recognition, as it were, of an old friend.

If the teacher is sufficiently cautious, she can discover without disturbing the children the moment when they have caught a new tune; and even if only a few succeed in following both of the first two melodies, the teacher can satisfy these few by alternating the tunes. This does not disturb the others who come, little by little, to notice the change in the music and to fall in with the new movement. In a public kindergarten at Perugia an attempt of this nature was made without warning by a lady, who, being a visitor, felt free to take this liberty. The children were invited into the large hall and left to themselves while the lady was playing on the piano our third melody, a march. The older children caught the

movement at once. After they had been marching for some time a *galop* was played. Some hesitation appeared in a few pupils while others apparently were not aware of the change in the music. Suddenly two or three began to run, as though swept away by the rhythmic wave, as though borne along by the music. They hardly seemed to touch that floor to which, but a few moments previously, the march seemed to have glued them at every step! A portion of the children in this class had taken seats in the sloping auditorium around the room. They were the youngest children; and when the victorious charge broke out to the tune of the *galop*, they began to clap their hands enthusiastically. Some of the teachers felt alarmed, but certainly the spectacle was an inspiring one.

It follows that if we are to *tell* the children to “hop,” “run,” or “march,” there is no use in our giving them music. We must take our choice: either *music* or *commands*. Even in our reading lessons with the slips, we do not tell the child the word that he must read. We must do without commands, without false accentuation of notes, without enforced positions. Music, if it be in reality an expressive language, suggests everything to children if they are left to themselves. Rhythmic interpretation of the musical thought is expressed by the attitude and movement of body and spirit.

Nannina, a girl four years old, would gracefully spread her skirt, and relax her arms along her body. She would bend her knees slightly, throw her head back and turning her pretty little face to one side, smile at those behind her as though extending her amiability in all directions.

Beppino, four and a half years old, stood with his feet

together motionless at the center of the ellipse drawn on the floor, on which the children were walking. He beat the time of the first tune with an outstretched arm, bowing from the waist in perfectly correct form at every measure. The time consumed in this bow of Beppino exactly filled the interval between one *thesis* and the next and was in perfect accord with the movement of the tune.

Nannina, the same pretty girl we mentioned above, always grew stiff when a military march was played; she would frown and walk heavily.

On the other hand, the intervention of the teacher to give some apposite lesson, tending to perfect certain movements, is something which gives the children extraordinary delight. Five of our little girls embraced each other rapturously and smothered the teacher with kisses when they had learned a few new movements of a rhythmic dance.

Otello, Vincenzino and Teresa had been taught to get a better effect from their tambourines, their steps and gestures. Each of them thanked the teacher for the profitable lesson in a special way. Vincenzino gave her a beaming smile whenever he marched past her; Teresa would furtively touch her with her hand; Otello was even more demonstrative — as he went by her he would leave the line, run to her and embrace her for a second or two.

If the spontaneity of every child has been respected; if, in other words, every child has been able to grow in his or her own way, listening to the tunes, following them with the footsteps and with free movements — interpreting them; if each child has been able to penetrate, without being disturbed by any one, into the heart of the beautiful fact which the understanding of music consti-

THIS PAGE IS LOCKED TO FREE MEMBERS

Purchase full membership to immediately unlock this page

Know Your Bible

Forgotten Books'
Full Membership
provides unlimited
access to more than
28,000 volumes of
Christian literature for
\$8.99/month

**HOLY
BIBLE**

Continue

*Fair use policy applies

possibilities of an orderly motory action; and when they had become quiet again, they began to listen to the music with great interest waiting for the revelation of its deep secret. Then suddenly they began to walk again, this time regularly and according to the real measure.

One of the children, whose graph was somewhat as follows:



(pauses, that is, on the line of quiescence, with frequent excursions into the negative field), took no part in these rhythmic exercises. On the contrary, he was always breaking them up by pushing the other children out of line or making a noise. Finally, however, he did learn not to disturb others; in other words, to stay *quiet*, something which he had never known how to do before. It is a great conquest for a disorderly child to gain the ability to become quite motionless, in a gently placid state of mind. His next step was to learn to move delicately, with respect for other people; and he came to have a certain sensitiveness about his relations with his schoolmates. For example, he used to blush when they smiled at him and even when he took no part in what they were doing, he shared their activities with an affectionate attention. From this point on Riziero (that was the child's name) entered on a higher plane of existence — one of order, labor and politeness.

The fact also that children at times listen to the music, while remaining seated comfortably around the room, watching the other children dance and march, is in itself a pretty thing. The children who are seated become very self-controlled. They watch their schoolmates or ex-

change a few words cautiously with each other. At times, even, they let themselves go in interesting expressions of movement with their arms. The manifestations of placidity and interest here seen cannot be disjoined from a healthful, spiritual upbuilding,—a beautiful orderliness, which is being established within them. Obviously, a wonderful harmony springs up between the teacher, who plays with enthusiastic feeling and with all possible skill of hand and abundance of spirit simply because she feels the musical phenomena around her in the children, and the pupils who, little by little, are transformed under this influence, and show an understanding of the music, which becomes for them something more and more intimate, more and more complete. It is no longer a question of the *step*, but of the position of the whole body: arms, heads, chests *are moved* by the music.

Finally, many of the children beat time with their hands, and interpret correctly without ever having been taught distinctions between 3 and 4 time, etc. When a keen interest in “guessing” the time is awakened in them, the children look about for various objects — wands, tambourines, castagnettes, etc., and the class exercise is developed to perfection. The child comes to be “possessed” by the music. He obeys the musical command with his whole body and becomes more and more perfect in this obedience shown by his muscles.

Here is a pretty story which will show to what extent children can feel themselves dependent on the music which “makes them move.” Once my father went into a room where a little Parisian girl whom he was very fond of was passionately marching to the rhythm of a tune played on the piano. The child usually ran to meet the old gentleman; but that day the moment she saw him

she began to shout to Miss Maccheroni, who was playing, “*Arrête, arrête!*” She wanted to go and shake hands with my father, something she could not do as long as the music was continuing to *command* her to move with the rhythm. And in fact, it was not until Miss Maccheroni stopped playing that the little girl was able to run and deliver her greeting.

.

We have prepared a series of tunes for this work and I think it will be useful to give here those which we finally selected because they have succeeded, whenever they were tried, in arousing in the children the phenomena above described. There are eight movements chosen from six well-known pieces of music. These few movements repeated over and over again and played with all possible accuracy, will surely, sooner or later, be felt in every rhythm by the children.

The transition from following the time by ones (that is, one beat for every rhythmic element) to the indication of simply the beginning of the measure (that is, one beat on the *thesis*) appeared for the first time in a “Children’s House” directed by Miss Maccheroni. There, one morning when the children were following the music with great pleasure, marching about and beating on tambourines, it was a girl who first caught the strong beat (*thesis*). A little boy behind her made the conquest a second later; but while the little girl lost what she had gained almost immediately, the little boy developed it to perfection. Shortly after other children made the same progress, apparently as a saving of effort: they began, that is, by beating once on every step. This required a rapid movement and an endless succession of beats. All of a sudden they began to beat on the first note of a measure.

THIS PAGE IS LOCKED TO FREE MEMBERS

Purchase full membership to immediately unlock this page



HISTORY

Tens of thousands of important historical sources, many previously unobtainable, are now available for the first time with a Forgotten Books Full Membership.

Unlimited Access
\$8.99/month

Continue

*Fair usage policy applies



The children using the music bells and the wooden keyboards. (*The Washington Montessori School, Washington, D. C.*)

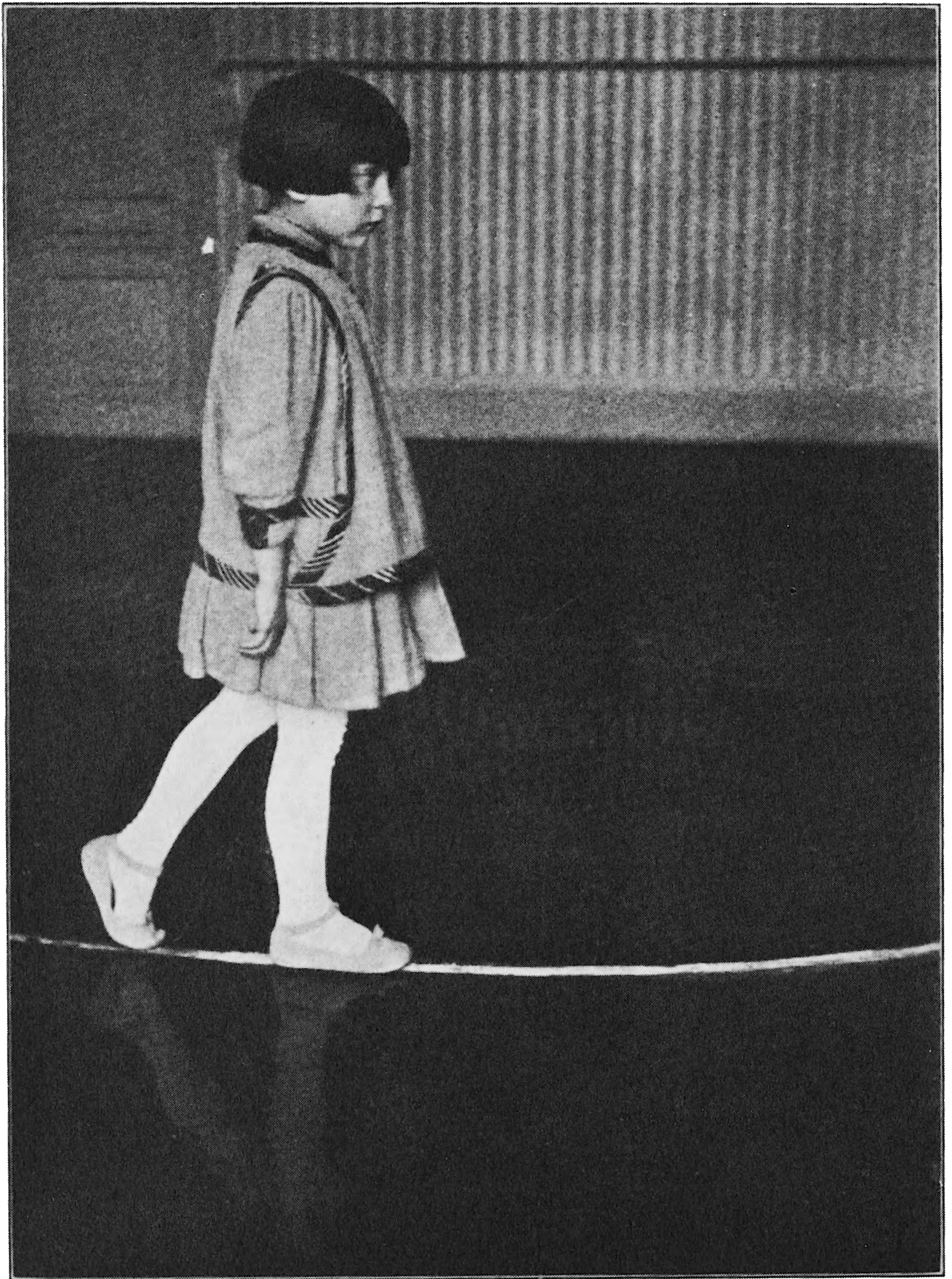

Analyzing the beat of a measure while walking on a line. (*A Montessori School in Italy.*)

ally *tempo forte* has no relation to the meaning of the words "strong" and "weak" in their ordinary sense. It is a question of *emphasis* and *expression*, which derive their nature from the laws of musical time and melodic composition and certainly not from the wrist muscles of the person playing. If this were not so, a person could play the first, second or third note of a measure as *forte*, whereas, in reality, it is the first that is always "strong."

In practise, children, to whom the six tunes we proposed for the beginning of this study were played — and played always with rigorous musical interpretation and with expressiveness — succeeded in recognizing the first beat of the measure as "strong," and went on thus to divide into measures some thirty pieces of music of varied rhythm. Even the following year, after the summer vacation, they kept asking for new pieces of music just for the "fun" of working out the measure in them. They would stand at the side of the teacher at the piano and either with their hands or with soft playing on the castagnettes or tambourines, accompany their new piece of music. In general they would listen in silence to the first measure and then fall in with their little beats like any well-trained orchestra. They took the trouble no longer to march to the music: they were interested in this new form of study; while the smaller tots, delighted with the new music, were still walking undisturbed along the elliptical line on the floor which was to guide them to such great conquests!

The strong beat (*thesis*) is the key that opens to the higher laws of music. Sometimes it is played, for reasons of expression, very softly and always possesses the solemnity of the note which dominates the rhythm. It may even be syncopated or lacking entirely, just as when

THIS PAGE IS LOCKED TO FREE MEMBERS

Purchase full membership to immediately unlock this page

Know Your Bible

Forgotten Books'
Full Membership
provides unlimited
access to more than
28,000 volumes of
Christian literature for
\$8.99/month

**HOLY
BIBLE**

Continue

*Fair use policy applies

for ordinary methods, namely, counting *one! two! three! four!* to keep step in time.

.

As a practical application of the information already acquired in the division of time into measures, we next pass to the exercise of playing the scales in 2/4, 3/4 and 4/4 time and with the triplets. The scale, the classic type of the melody, lends itself beautifully to these interpretations of various measures. Every one must have passed hours at the piano playing simple scales and finding a delicious variety in the exercise. The *do* scale itself may be played, for instance, thus:



or thus:



or thus:



Our little piano may be of use in this exercise; but it is better first to use an exercise more easy for finger movement and for the position of the hand:

.

Children who have succeeded in identifying and dividing the melody into measures and the measure itself into

2, 3, 4, understand very easily the time values of the notes. It is sufficient to let the child *hear* each exercise

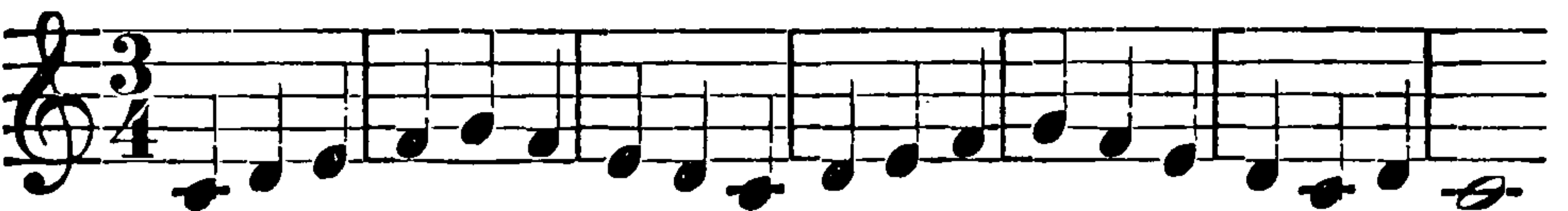
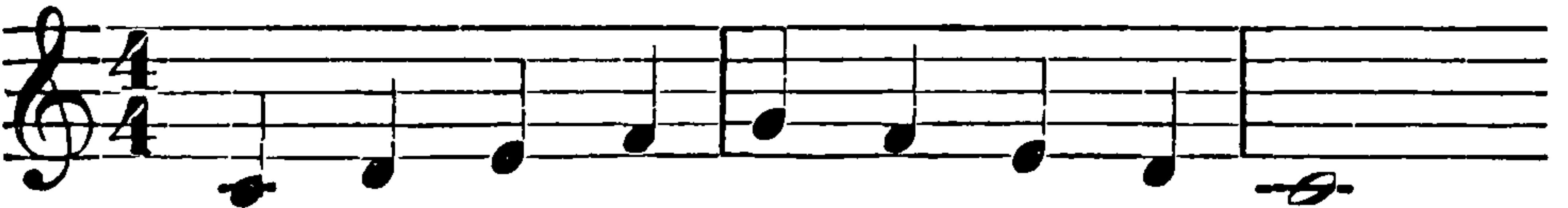

first and he will repeat it with precision. Thus all kinds of dry explanation of musical *values* disappear.

The following notation

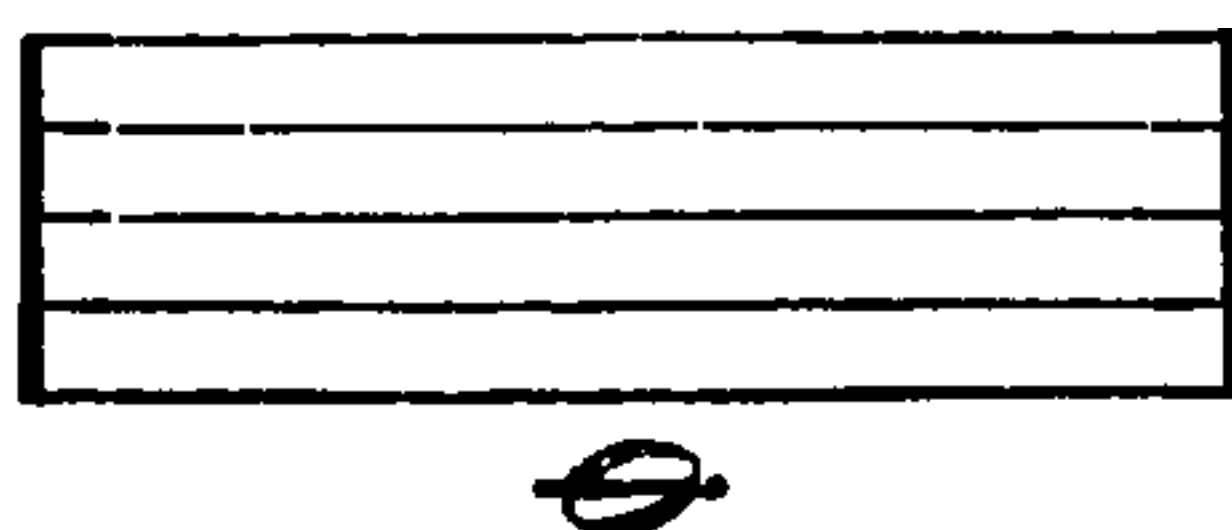

presents no special difficulty if the child has once heard it.

Our next step is to use some exercises for the analysis of the measure, for instance:

The image displays six musical exercises on a single staff in treble clef, each divided into four measures. The exercises are as follows:

- Exercise 1: Measure 1: quarter notes G4, A4, B4, C5; Measure 2: half note D5; Measure 3: quarter notes D5, C5, B4, A4; Measure 4: half note G4.
- Exercise 2: Measure 1: quarter notes G4, A4, B4, C5; Measure 2: half note D5; Measure 3: quarter notes D5, C5, B4, A4; Measure 4: quarter notes G4, F4, E4, D4.
- Exercise 3: Measure 1: quarter notes G4, A4, B4, C5; Measure 2: half note D5; Measure 3: quarter notes D5, C5, B4, A4; Measure 4: half note G4.
- Exercise 4: Measure 1: quarter notes G4, A4, B4, C5; Measure 2: half note D5; Measure 3: quarter notes D5, C5, B4, A4; Measure 4: half note G4.
- Exercise 5: Measure 1: quarter notes G4, A4, B4, C5; Measure 2: half note D5; Measure 3: quarter notes D5, C5, B4, A4; Measure 4: half note G4.
- Exercise 6: Measure 1: quarter notes G4, A4, B4, C5; Measure 2: half note D5; Measure 3: quarter notes D5, C5, B4, A4; Measure 4: quarter notes G4, F4, E4, D4.

The children follow these exercises, marching so as to put one step on every note. Even children of four years when prepared with the preceding exercises succeed in following these with the very greatest interest. They are

THIS PAGE IS LOCKED TO FREE MEMBERS

Purchase full membership to immediately unlock this page



HISTORY

Tens of thousands of important historical sources, many previously unobtainable, are now available for the first time with a Forgotten Books Full Membership.

Unlimited Access
\$8.99/month

Continue

*Fair usage policy applies

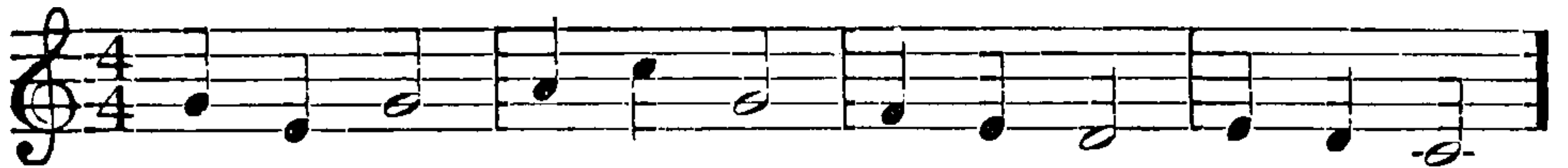

Of course, sooner or later children fix their attention on the varying form of the notes and discover that this difference in form bears a relation to differences in time-value of the notes:



This is the time to give in very brief explanation the lesson on the value of the notes. Thereafter the child may write from memory a simple melody which the teacher has first played on the piano. Almost always the child writes this down with accuracy, showing that he has control over the musical values appearing in the melody in question. The child uses for this purpose a large green chart containing various musical staves on which movable notes may be fixed at pleasure. These notes are equipped with a pin which may be pushed into the wood. The simple exercises given for the analysis of the measures, transferred into various keys, can after some practise in playing them on the system of plates be put into their copy books by the children. These exercises for measure-analysis are so simple that the children themselves have sometimes learned to play them on the piano. It then has happened that the class went of its own accord into the piano room; one child began to play and the others followed the music on the floor-line. The children as they walk ultimately come to sing the scales and the easy tunes (of which they have recognized the notes) pronouncing the names of the notes; but in so pronouncing them they soften their voices to the point of attaining an expression

which may be called even artistic. When the teacher plays, the music gains the added charm of harmony, since the teacher can give not only the simple scale, but the relative chords, and this gives the scale a vigorous and very sweet fullness.

These exercises in measure analysis have also been particularly useful in their application to gymnastic exercises. The children follow them with gymnastic movements, using especially the movements of Dalcroze, which are admirably adapted to the measures of $\frac{2}{4}$, $\frac{3}{4}$, $\frac{4}{4}$, etc., and which have a real beauty. We discovered that these exercises proved to be complexly difficult for the children who had not practised sufficiently in the interpretation of the different note values. On the other hand, they were very easy for those who had come to have a clear feeling for these different values. This was proof to us that sensorial preparation must precede these exercises, and furthermore, that the only difficulty Dalcroze movements encounter in children arises from insufficient sensory preparation in the children themselves.

In the same way we illustrate the different details of musical writing: the dotted note,



the triplet:

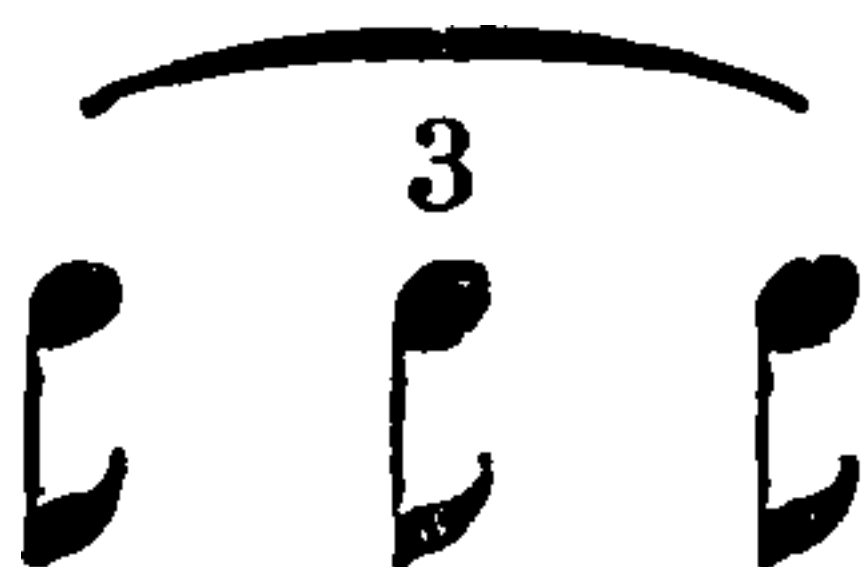

the *legato*, the *staccato*, etc.

Here is an example of a *legato* effect:



(Sonnambula. Quintet)

This example which derives all its expressive value from the ties, also brings out the value of the note:



We need, accordingly, a collection of musical selections in which the value of the notes is obvious and clear to such an extent that the children come to recognize the different values. This recognition must be obtained by ear through listening to the music, not by eye looking at the symbols while the teacher explains.

The $\frac{1}{4}$ note always has a different musical content from the $\frac{1}{16}$ note. A musical piece made up of the 16th or 32d notes has a character of its own (joy or agitation); and a piece made up of half or whole notes has likewise its peculiar character (religious, sad, impressive).

The same may be said of every musical symbol, the value of which is brought out by the note being played

THIS PAGE IS LOCKED TO FREE MEMBERS

Purchase full membership to immediately unlock this page

Know Your Bible

Forgotten Books' Full Membership provides unlimited access to more than 28,000 volumes of Christian literature for \$8.99/month

HOLY BIBLE

Continue

*Fair use policy applies



tionless executing plastic poses with their arms. This revealed to us their sensitiveness to melody; they felt moved not to march but to pray and assume various poses.

We have not yet been able to push our experiments far enough precisely to define the musical material adapted to children of various ages. We have, however, made a very great number of successful attempts to bring children to enjoy melody and sentimental expression in music. The practicableness and utility of musical auditions, or, if you wish, of concerts for children, graduated in difficulty, executed on various instruments, but on one instrument at a time, are beyond all question; this applies above all to songs reproduced by the human voice, when a well-trained voice is available.

If a real artist should take up the task of analyzing for children the language of music, bringing them to enjoy it phrase by phrase and under different *timbres* (voice, strings, etc.), his new and scientific application of the art would prove to be a real benefaction to humanity. How many people capable of profound enjoyment of music would be produced in the future from these groups of little ones, so intelligent in music, who follow the most expres-

sive tunes with so much passion and in a silence more absolute than any celebrated artist can dream of attaining in a meeting of adults! No one among these little hearers is cold, far away in thought. But on the faces of the children appears the interior working of a spirit, tasting a nectar essential to its very life.

How many times a plastic pose, a kneeling posture, an ecstatic face, will move the heart of the artist to a sense of joy greater than that which any applause of a throng of people often indifferent or inattentive, can possibly give him! Usually only those wounded at heart by the difficulty of being understood by others, or discouraged by the coldness or rudeness of other people, or oppressed by disillusion, or filled with a sense of painful loneliness or need of expansion in some other way, feel in music the voice which opens the doors of the heart and causes a health-giving flood of tears or raises the spirit to a lofty sense of peace. Only they can understand how necessary a companion for humanity music is. We know, of course, to-day that music is an indispensable stimulant for soldiers rushing forth to die. How much more truly would it then become a stimulant for all who are to live!

This conviction is already in the hearts of many people. In fact, attempts have already been made to reach the populace by concerts in the public squares and by making concert halls accessible to people of every class; but after all, do such attempts amount to more than putting the cheap editions of the classics into circulation among illiterates? Education is the prime requisite; without such education we have a people of deaf mutes forever barred from any music. The ear of the uneducated man cannot perceive the sublime sounds which music would bring within his reach. That is why though

the music of Bellini and Wagner is being played in public squares, the saloons are just as full as before.

If, however, from these pupils of ours a whole people could grow up, it would be sufficient to go through the streets with a good piece of music and everybody would come out to hear. All those places where the rough and abandoned wrecks of humanity seek enjoyment, like homeless dogs looking for food in our ash-cans, would be emptied as if by magic. We would have an actual realization of the Allegory of Orpheus; for hearts which are to-day of stone would then be stirred and brought to life by a sublime melody.

SINGING

Singing began with the scale. The singing of a scale, first in accompaniment with the bells and later with the piano is a first and great delight to the children. They sing it in various ways, now in a low voice, now very loud, now all together in unison, now one by one. They sing divided into two groups, sharing the notes alternately between them. Among the songs which we offer to the children, the greatest favorite proved to be the syllabic Gregorian Chant. It is something like a very perfect form of speech. It has a conversational intonation, the softness of a sentence well pronounced, the full roundness of the musical phrase. The examples given here have almost the movement of the scale.

Many other verses of the Gregorian Chant have, like these, proved to be the delight of the Montessori Elementary School of Barcelona. There the children are especially keen about this very simple music which they like to play on the piano, on their plates (Xylophones) or on their monochords.

THIS PAGE IS LOCKED TO FREE MEMBERS

Purchase full membership to immediately unlock this page



HISTORY

Tens of thousands of important historical sources, many previously unobtainable, are now available for the first time with a Forgotten Books Full Membership.

Unlimited Access
\$8.99/month

Continue

*Fair usage policy applies

MUSICAL PHRASES FOR THE INITIAL RHYTHMIC
EXERCISES

We give here in complete form the musical phrases used by us for the first rhythmic exercises. They are adequate for giving the sensation of rhythm and for suggesting the motory actions associated with the rhythm. This musical material now forms in our schools part of the material which is experimentally established.

*Works from which Selections are Taken Motor Reactions
Provoked*

1. "Ancora un bacio," mazurka, Bastianelli.. Slow walk.
2. "Si j'étais roi," Adolphe Adam..... Accelerated walk.
3. "Eagle March," Wagner..... March step.
4. "Galop," Strauss Run.
5. "Italian folk-song" Hop.
6. "Pas des patineurs" Sedate walk.

ANCORA UN BACIO
(Mazurka)

Bastianelli.

The first system of musical notation consists of two staves. The upper staff is in treble clef and the lower staff is in bass clef. The key signature has two flats (B-flat and E-flat), and the time signature is 3/4. The music begins with a dynamic marking of *pp*. The melody in the upper staff features several triplet figures, each marked with a '3' above the notes. The bass line provides a simple harmonic accompaniment with chords and single notes.

The second system of musical notation continues the piece. It features a *cresc.* (crescendo) marking in the first measure of the upper staff. The melody continues with triplet figures. In the third measure of the upper staff, there is a dynamic marking of *p* and the instruction *legatiss.* (legatissimo). The bass line continues with its accompaniment.

The third system of musical notation shows the continuation of the melody and accompaniment. The upper staff contains several more triplet figures. The bass line maintains the harmonic support.

The fourth system of musical notation concludes the piece. It features the final triplet figures in the upper staff and the final chords in the bass line.



SI J'ÉTAIS ROI

Adolphe Adam.

Andante sostenuto.



THIS PAGE IS LOCKED TO FREE MEMBERS

Purchase full membership to immediately unlock this page

Know Your Bible

Forgotten Books' Full Membership provides unlimited access to more than 28,000 volumes of Christian literature for \$8.99/month

**HOLY
BIBLE**

Continue

*Fair use policy applies

First system of musical notation. Treble clef, key signature of one sharp (F#). The melody in the treble clef consists of eighth and quarter notes. The bass clef accompaniment features a steady eighth-note pattern. Dynamic markings include *pp* and accents (>).

Second system of musical notation. Treble clef, key signature of one sharp (F#). The melody continues with eighth and quarter notes. The bass clef accompaniment remains consistent. Dynamic markings include *p* and *pp*.

Third system of musical notation. Treble clef, key signature of one sharp (F#). The melody features a triplet of eighth notes. The bass clef accompaniment includes a triplet of eighth notes. Dynamic markings include *ff energico.* and accents (>).

Fourth system of musical notation. Treble clef, key signature of one sharp (F#). The melody concludes with a half note. The bass clef accompaniment ends with a half note. Dynamic markings include accents (>).

GALOP

Strauss.

The first system of musical notation consists of two staves, treble and bass, in 2/4 time with a key signature of one sharp (F#). The treble staff begins with a treble clef, a sharp sign, and a 2/4 time signature. The bass staff begins with a bass clef, a sharp sign, and a 2/4 time signature. The music is written in a rhythmic, galop style with eighth and sixteenth notes.

The second system of musical notation continues the piece with two staves, treble and bass, in 2/4 time with a key signature of one sharp (F#). The notation follows the same rhythmic pattern as the first system.

The third system of musical notation continues the piece with two staves, treble and bass, in 2/4 time with a key signature of one sharp (F#). The notation follows the same rhythmic pattern as the first system.

The fourth system of musical notation concludes the piece with two staves, treble and bass, in 2/4 time with a key signature of one sharp (F#). The final measure of the treble staff ends with a double bar line and a repeat sign (two dots), and the bass staff also ends with a double bar line and a repeat sign.

ITALIAN FOLK SONG

The first system of musical notation consists of two staves. The upper staff is in treble clef, and the lower staff is in bass clef. Both staves are in the key of D major (one sharp) and 2/4 time. The melody in the treble staff begins with a quarter rest, followed by a quarter note D4, an eighth note E4, a quarter note F#4, and a quarter note G4. The bass staff provides accompaniment with a series of chords and moving lines.

The second system of musical notation continues the piece. The treble staff features a melody of quarter notes: G4, F#4, E4, and D4. The bass staff continues with accompaniment, showing a rhythmic pattern of eighth and quarter notes.

The third system of musical notation concludes the piece. The treble staff melody consists of quarter notes: C4, B3, A3, and G3. The bass staff accompaniment continues with a similar rhythmic pattern, ending with a final chord in the bass clef.

THIS PAGE IS LOCKED TO FREE MEMBERS

Purchase full membership to immediately unlock this page



HISTORY

Tens of thousands of important historical sources, many previously unobtainable, are now available for the first time with a Forgotten Books Full Membership.

Unlimited Access
\$8.99/month

Continue

*Fair usage policy applies

O SANCTISSIMA

Andante.

The musical score is written for piano in G major (one sharp) and 2/4 time. It consists of three systems of two staves each. The first system begins with the tempo marking *Andante.* The second system includes a piano (*p*) dynamic marking and a crescendo (*cresc*) marking. The piece concludes with a final cadence in the third system.

MUSICAL AUDITIONS

The movement entitled "O Sanctissima," played by Miss Maccheroni one day by chance among the rhythmic exercises, is regarded by us as an introduction to *musical audition*. It will be recalled that the children had been accustomed to alter their style of marching on the floor-line according to changes in the music. It had never, however, occurred to them to leave the line. When this piece was played they all crowded around the piano, motionless, thoughtful, absorbed; while two or three little ones fell to their knees and assumed various poses. This experience suggested to us the idea of "musical auditions," if you wish "concerts for children."

Children, little by little to be sure, but no less admirably, enter into the spirit of music. After the numerous rhythmic exercises, as soon, that is, as they have mastered the problem of measure, almost any *sonata* is within their reach. They can handle not isolated movements merely, but whole pieces of music. The same is true of the auditions. At first, of course, it is better to select simple phrases; but gradually the children come to enjoy "the best music," joyfully recognizing the feeling which it expresses and which inspired it. Our pupils used to exclaim, for instance: "This piece is for weeping," "This is for prayer," "Now we must laugh," "Now we must shout," etc.

We cannot, however, insist too strongly on the need

for the greatest possible care in the execution of the selections used. A child audience is a very special one. It demands something more than is expected by the average "intelligent audience." It is one in which musical intelligence must be *developed*. Our object must be the creation not merely of higher and higher grades of understanding but also of higher and higher grades of *feeling*. In this sense, we can never *do too much* for the children. It is a task not beneath the dignity of the greatest composers, the most accomplished technicians. Indeed, any one of such might well esteem it a privilege some day to hear it said of his work that it aroused the first love for music in the hearts of one of these little ones. For thus music would have been made a companion, a consoler, a guardian angel of man! It is of course not the lot of all of us to attain the exalted position of greatness whether as artists or technicians. We must content ourselves with assuming an obligation: with *giving* all the soul and all the skill we possess. We must conceive of ourselves as transmitters of the largess of music to our children. We must deeply feel our calling as bestowers of a divine gift.

The following titles were all used successfully by us in our experiments. They are supplements to the "O Sanctissima" and a "Pater Noster."

A. NARRATIVES.

Trovatore: "Tacea la notte placida."

Lucrezia Borgia: "Nella fatal di Rimini e memorabil guerra."

Lucia di Lamermoor: "Regnava nel silenzio."

Trovatore: "Racconto di Azucena."

Sonnambula: "A fosco cielo, a notte bruna."

Rigoletto: "Tutte le feste al tempio."

Fra Diavolo: "Quell'uom dal fiero aspetto."

THIS PAGE IS LOCKED TO FREE MEMBERS

Purchase full membership to immediately unlock this page

Know Your Bible

Forgotten Books'
Full Membership
provides unlimited
access to more than
28,000 volumes of
Christian literature for
\$8.99/month

**HOLY
BIBLE**

Continue

*Fair use policy applies

*Invitation:**Faust:* "Permetteresti a me."*Bohème:* song of Rudolph, "Che gelida manina."*Anger:**Sonnambula:* "Ah perchè non posso odiarti."*Sorrow of sacrifice:**Bohème:* "Vecchia zimarra senti."*Meditation:*

Mendelsohn: Romances.

Mozart.

Chopin.

D. FOLK SONGS AND DANCES.

PART VII
METRICS

THIS PAGE IS LOCKED TO FREE MEMBERS

Purchase full membership to immediately unlock this page



HISTORY

Tens of thousands of important historical sources, many previously unobtainable, are now available for the first time with a Forgotten Books Full Membership.

Unlimited Access
\$8.99/month

Continue

*Fair usage policy applies

THE STUDY OF METRICS IN ELEMENTARY SCHOOLS

One of the novelties included in our experiments was the teaching of metrics, hitherto reserved for high schools. The love shown by children for poetry, their exquisite sensitiveness to rhythm, led me to suspect that the native roots of poetry might be present in little children. I suggested to Miss Maria Fancello, a teacher of literature in the high schools and my colleague, to attempt such an experiment. She began with children of different ages, and, together, we succeeded in discovering a highly interesting department of education, the object of which might be to give the mass of the people, prepared for life in the primary schools, the basic elements of literary appreciation, thus opening a new source of pleasure calculated also to increase general enlightenment. A populace capable of enjoying poetry, of judging the beauty of verse, and hence of coming in contact with the spirits of our greatest poets, would be something quite different to the masses we now know. To find the like we have to imagine the people of ancient story, who talked in poetry and moved their bodies to the rhythm, thus laying the foundations of refined civilization.

It is not our intention to describe in detail all we did in these experiments. It will be sufficient to summarize

the results, which may suggest useful material and methods to others.

As soon as the children are somewhat advanced in reading, poetry, which they loved so much in the "Children's House," may be included in the materials offered in partial satisfaction of their insatiable desire to read. It is best to begin with poems composed of stanzas of different lengths, the stanzas being printed at easily noticeable intervals from each other. The lines may be counted, in teaching the two new words "stanza" and "line." The process involved is a recognition of "objects," suggesting the first exercise in reading, where the children put *names* on things; though here the situation is much simpler. At the same time we have the exercise of counting the lines. In short, it is a review exercise of the greatest simplicity.

The counting of the lines leads at once to the identification of such groups as the couplet, quatrain, octave, etc. But little time is spent on such a crude detail. The little ones almost immediately become interested in the rhyme. The first step is the recognition of rhyming syllables which are underlined with colored pencils, using a different color for each rhyme. Seven-year-olders take the greatest delight in this work, which is too simple to arouse interest in children of eight or nine. Those of seven do such work about as quickly as those of ten, the speed of the younger children being due apparently to their enthusiasm, the slowness of the older to their lack of interest. We may note in passing that these exercises furnish tests of absolute exactness as to rapidity of work. Children of eight are able to go one step beyond marking the rhymes with colored pencils. They can use the more complicated device of marking lines with the letters of the

alphabet: aa, bb, cc, etc. Marking with numbers to the left the lines in their order, and the rhymes with letters to the right, we get a specimen result as follows:

1°	Rondinella pellegrina	a
2°	Che ti posi sul verone	b
3°	Ricantando ogni mattina	a
4°	Quella flebile canzone	b
5°	Che vuoi dirmi in tua favella	c
6°	Pellegrina rondinella?	c

(Translation: "Wandering swallow, as you sit there on my balcony each morning, singing to me your tearful song, what is it you are trying to tell me in your language, wandering swallow?")

This brings out the difference between the alternating rhyme (a, b, a, b) and the couplet (c, c), as well as the morphology of the stanza.

.

In reading the lines over and over again to work out the rhyme scheme, the children spontaneously begin to catch the tonic accents. Their readiness in this respect is a matter of common observation. In fact, in ordinary schools, the teachers are continually struggling against the "sing-song" developed by children in reading poetry. This "sing-song" is nothing more nor less than stress on the rhythmic movement.

On one occasion, one of our children, a little boy, had been spending some time over a number of decasyllabic lines. While waiting in the corridor for the doors to open at dismissal time, he suddenly began to walk up and down "right-about-facing" at every three steps and saying aloud: "tatatá, tatatá, tatatátta," right-about-face, then "tatatá, tatatá, tatatátta." Each step was accompanied

THIS PAGE IS LOCKED TO FREE MEMBERS

Purchase full membership to immediately unlock this page

Know Your Bible

Forgotten Books' Full Membership provides unlimited access to more than 28,000 volumes of Christian literature for \$8.99/month

**HOLY
BIBLE**

Continue

*Fair use policy applies

ard is broken out to the breeze; there another advances waving; here a line of troops appears, there another rushing against it.”)

2. Dodecasyllables: example:

Ruéllo, Ruéllo, divóra la vía,
Portáteci a vólo, bufére del ciél.
È préssò alla mórte la vérgine mía,
Galóppa, galóppa, galóppa Ruél.

(PRATI, *Galoppo notturno.*)

(Translation: “Ruello, Ruello, as fast as you can! O storm-winds of heaven, lend us your wings; my loved one is lying near death; onward, onward, onward, Ruello!”)

3. Eight syllable lines (*ottonario*): example:

Solitáριο bosco ombróso,
A te viéne afflitto cór,
Per trovár qualche ripóso
Fra i silénzi in quest'orrór.

(ROLLI, *La lontananza.*)

(Translation: “O deserted wood! To your shade the sorrowing heart comes to find some rest in your cool silence.”)

4. Six syllable lines (*senario*): example:

Pur báldo di spéme
L'uom último giúnto
Le céneri préme
D'un móndo defúnto;
Incálza di sécoli
Non áncò matúri
I fúlgidi aúgúri.

(ZANELLA, *La conchiglia fossile.*)

(Translation: “Radiant with hope, the latest comer treads on the ashes of a dead world, pursuing the glowing aspirations of ages not yet ripe.”)

NOTE: In the above selections the vowels in broad-faced

type have been marked with an accent by the child, to indicate the rhythmic beat.

We found, on the other hand, that greater difficulty is experienced by the children in lines where the syllables are in odd-numbers (imparisyllabics), the hardest of the Italian lines being the hendecasyllable, which is a combination of the seven syllable and the five syllable line, fused together with all their great varieties of movement.

We established the following gradation of difficulties:

1. Seven syllable line (*settenario*): example:

Già riéde Prímavéra
Col súo fioríto aspétto,
Già il gráto zéffirétto
Schérza fra l'érbe e i fiór.

(METASTASIO, *Primavera*.)

(Translation: "Now already flowery Spring returns; again the lovely zephyrs dance amidst the grass and blossoms.")

2. Five syllable line (*quinario*): example:

Viváce símbolo
Dé la famíglia,
Le diè la trémula
Mádre a la fíglia,
Le diè la suócera
Buóna a la nuóra
Ne l'últim' óra.

(MAZZONI, *Per un mazzo di chiavi*.)

(Translation: "As a vivid symbol of the home, they were passed on by the dying mother to her daughter or to her son's wife.")

3. Nine syllable line (*novenario*): example:

Te trístè! Che a välle t'aspéttano
I giòrni di cántici prívi;
Ah nó, non dai mórti che t'ámano,
Ti guárda, fratéllo, dai vívi.

(CAVALLOTTI, *Su in alto*.)

(Translation: "Alas, for thee, O brother! Yonder, songless days await thee. Ah no, have no fear of the dead: they love thee! The living only shouldst thou fear!")

4. Hendecasyllable: example:

Per me si vá nella cittá dolénte,
 Per me si vá nell' etérno dolóre,
 Per me si vá tra la perdúta génte.

(DANTE, *Divina Commedia, Inferno.*)

(Translation: "Through me ye enter the city of sorrow; through me ye enter the realm of eternal grief; through me ye enter the regions of the damned").

The typical ending of these various lines is the trochee (— ∪, *verso piano*). The iambic (∪ —, *verso tronco*) and the dactylic (— ∪ ∪, *verso sdrucchiolo*) endings (requiring respectively one syllable less and one syllable more than the *verso piano*) constitute occasional variations. We have found that these rarer lines are recognized rather as curiosities than as difficulties by the children who easily refer them to their respective normal types. They are accordingly presented in our material along with the common verses of trochaic endings. Our illustration of the five syllable line given above showed specimens of the dactylic ending (*sdrucchiolo*, — ∪ ∪). Here is another example of alternating trochaic (*piano*) and dactylic endings:

In cima a un álbero
 C'è un ucellíno
 Di nuóvo género. . . .
 Che sía un bambíno?

(L. SCHWARZ, *Uocellino.*)

(Translation: "There's a very strange little bird up in that tree! Why, it's a little child!")

THIS PAGE IS LOCKED TO FREE MEMBERS

Purchase full membership to immediately unlock this page



HISTORY

Tens of thousands of important historical sources, many previously unobtainable, are now available for the first time with a Forgotten Books Full Membership.

Unlimited Access
\$8.99/month

Continue

*Fair usage policy applies

steamer flying the white, red and green. It stopped at Ponza, remained a while and then came back — came back and approached the shore. They came ashore in arms, but to us they did no harm”).

While the rhythmic accents were being studied, we found that the discovery of the cæsura (interior pause) formed an interesting recreative diversion. In fact this work aroused so much enthusiasm that the children went from exercise to exercise, continuing at study for extended periods, and far from showing signs of weariness, actually increased their joyous application. One little girl, in the first six minutes of her work, marked the cæsura of seventy-six ten-syllable lines without making a mistake. An abundant material is necessary for this exercise. Example:

Dagli atri muscosi, | dai fori cadenti,
 Dai boschi, dall' arse | fucine stridenti,
 Dai solchi bagnati | di servo sudor,
 Un volgo disperso | repente si desta,
 Intende l'orecchio, | solleva la testa,
 Percosso da novo | crescente rumor.

(MANZONI, *Italiani e Longobardi*.)

(Translation: “From the damp atria, from the ruined squares, from the forests, from the hissing forges, from the fields bathed with the sweat of slaves, a scattered horde of men suddenly is roused. They listen, lift their heads, startled at this strange increasing roar”).

The step forward to the perception of the syllabic units of the line is a purely sensory phenomenon: it is analogous to marking the time of music without taking account of the measure divisions. Syllabiating according to

rhythm and beating on the table with the fingers solve even the subtler difficulties such as dieresis and synalepha, in recognizing the rhythmic syllables. Examples:

La | so | mma | sa | pi | en | za e'l | pri | mo A | mo | re

We print this verse in the above form, because it was thus divided by a child in his very first spontaneous effort at syllabiation. As a matter of fact, we present the material normally according to graded difficulties, using over again for this purpose the materials used in the study of accents. At this point also the accents themselves suddenly acquire a new interest, for the child is able to observe on "what syllable they fall." Thus his metrical study approaches completion, for now he can readily acquire the nomenclature of metrics and versification: *dodecasyllable*, *hendecasyllable*, etc. Then, combining his knowledge of the numbers of syllables and the location of the rhythmic accents, the child is at the point of discovering the rhythmic laws of verse construction. We were expecting the children to begin producing definitions like the following: "The dodecasyllable line has twelve syllables and four accents which fall on the second, fifth, eighth and eleventh syllables," etc. The spontaneous impulse of the pupils led instead to the construction of "mirrors" or "checkerboards" like the following:

THIS PAGE IS LOCKED TO FREE MEMBERS

Purchase full membership to immediately unlock this page

Know Your Bible

Forgotten Books' Full Membership provides unlimited access to more than 28,000 volumes of Christian literature for \$8.99/month

**HOLY
BIBLE**

Continue

*Fair use policy applies

The next development is a complete study of the stanza or strophe in the form of a summary; the number of lines, the rhymes, the accents, number and location of the syllables. To *distinguish* between the stanzas is also to classify them, which becomes a pleasing task for the children.

One little girl, who was making a summary study of four terzets of Dante, suddenly called the teacher to inform her with an expression of complete surprise: "See, the rhyme always begins at the last accent!" She had before her:

Per me si va nella città dolente;
 Per me si va nell'eterno dolore;
 Per me si va tra la perduta gente.
 Giustizia mosse il mio alto fattore;
 Fecemi la divina potestate,
 La somma sapienza e il primo amore.
 Dinanzi a me non fur cose create. . . .

(Dante: Inscription over Gate of Hell.)

So in metrics also the children, following the natural inclinations of their growth, pass from sensory discipline, to intelligent cognition, and graphic representation. Then they become the "explorers of their environment," the "discoverers" of general laws.

* * *

Translator's Note: The basis of Italian verse is in the syllable count, and the rhythmic accent. In English verse, however, the question of the syllable count is dependent on a much more complex consideration: syllable length; and syllable length, in its turn, is conditioned not only by the phonetic situation in and around the syllable, but by rhetorical stress as well. It is clear that Signora

Montessori's experiments on the simpler Italian line have little direct bearing, save as an illustration of method, on the pedagogy of English Metrics. For whereas, the principal classifications of Italian lines involve merely the problem of syllabiation (complicated by dieresis and synalepha), with a numerical terminology (*quinario, ottonario, decasillabo*, etc.), the study of English versification demands an analysis of measure (feet) and of number of feet, with a terminology relative to each: trochee, iambus, dactyl, spondee, anapest, etc., hexameter, pentameter, etc., to mention only the most obvious elements of a science which, applied even to simple English verse, soon becomes extremely complicated. How much, then, of the study of English metrics, beyond the elementary concepts of stanza and rhyme, should be included in the Montessori Advanced Method, and what order of presentation of facts should be followed, still remains to be experimentally determined.

However, the most illuminating fact, as regards method, which detaches from Signora Montessori's experiments with metrical forms, is that *long parisyllables* are more readily analyzed by children than *imparisyllables*; and secondly that *short* *imparisyllables* prove easier than long *imparisyllables*. We might wish more explicit evidence that the hardest *parisyllable* is easier, therefore more *natural*, than the easiest *imparisyllable* — as implied in Signora Montessori's presentation of this subject. Even so, her conclusions are interesting, and from more than one point of view. It will be recalled that the most ancient and the most fortunate of the meters used in French, Spanish, and Provençal poetry is precisely the decasyllable (*Song of Roland*, the Provençal *Boecis*, etc.), whereas the favorite line of old Italian popular poetry was the octo-

syllabic verse. These are both parisyllables, though the succession of *theses*, or rhythmic beats, is not quite analogous to that of the modern Italian verses used in this experiment. It would seem, in fact, as though the children initiated by Signora Montessori into metrical studies, were actually traversing the earlier experiences of their Latin race.

Doubtless the reason why the parisyllable submits more readily to rhythmic analysis than imparisyllables, is that when the syllables are in even numbers, the line tends to reduce to two simple rhythmic groups — the decasyllable to groups of 4 and 6, with two rhythmic beats in each group; the dodecasyllable to groups of 6 and 6 (therefore of 3 and 3 and 3 and 3); the octosyllables to groups of 4 and 4; the six syllable to groups of 3 and 3. The imparisyllables on the contrary are rarely capable of such division — of such *monotony*, if you wish. They lend themselves to more complex rhythm, especially to “paragraphic” treatment. They are distinctly the rhythms of erudite, “cultivated,” “literary” poetry.

We should suspect, accordingly, that what appears in the above experiments as *length* is in reality *reducibility* to simpler forms; and that lines capable of such reduction should be given first in an adaptation of Signora Montessori’s method. It is, however, highly improbable that in English, where the only constant element in rhythm is the stress and not the syllable count, the line compounded of two simpler rhythmic groups should prove easier for the child than either of these simpler groups themselves. We see no reason to assume, for instance, than an eight-stress line, reducible to two four-stress lines, should be more readily analyzed than a four-stress line; or that a seven-stress line, reducible to a four-stress and

THIS PAGE IS LOCKED TO FREE MEMBERS

Purchase full membership to immediately unlock this page



HISTORY

Tens of thousands of important historical sources, many previously unobtainable, are now available for the first time with a Forgotten Books Full Membership.

Unlimited Access
\$8.99/month

Continue

*Fair usage policy applies

Trochaic:

Haíl to theé blithe spírit!
 Bírd thou néver wért,
 Thát from heáven or neár it
 Poúrest thý full heáart. . . .

SHELLEY.

Anapestic:

I am mónarch of áll I survéy;
 My ríght there is nóne to dispúte;
 From the céntre all roúnd to the seá
 I am lórd of the fówl and the brúte.

COWPER.

Dactyllic:

This is a spráy the bird clúng to,
 Máking it blóssom with pleásure,
 Ère the high treé-tops she sprúng to,
 Fít for her nést and her treásure.¹

BROWNING.

FOUR-STRESS LINES (TETRAMETER)

Iambic:

Examples: Byron, *The Prisoner of Chillon*; Scott, *The Lady of the Lake*; Milton, *Il pensieroso*.

We coúld not móve a síngle páce,
 We coúld not seé each óther's fáce
 But wíth that pále and lívid líght
 They máde us stráangers ín our síght. . . .

BYRON.

Trochaic:

Examples: Longfellow, *Hiawatha*; George Eliot, *The Spanish Gipsy*.

Wéstward, wéstward Híawátha
 Saíled intó the fiéry súnset,
 Saíled intó the púrple vápors,
 Saíled intó the dúsk of évening.

¹ Most of our examples of various types and combinations of verse are taken from Alden, *English Verse*, New York, Henry Holt.

This line is much more common in its catalectic form:

Háste thee nýmph and bríng with thée
Jést and youúthful jóllitý,
Quíps and cránk and wánton wíles,
Nóds and bécks and wreáthed smíles. . .

MILTON, *L'Allegro*.

Anapestic:

Examples: Goldsmith, *Retaliation*; Byron, *The Destruction of Sennacherib*.

The smáll birds rejoyce in the greén leaves retúrning,
The múrmuring streámlet winds cleár through the vále.

BURNS.

Dactyllic:

Examples: Byron, *Song of Saul*; Dryden, *An Evening's Love*.

Áfter the pángs of a désperate lóver,
Whén day and níght I have síghed all in vaín,
Áh what a pleásure it ís to discóver
In her eyes píty, who caúses my paín.

DRYDEN.

TWO-STRESS LINES

Iambic:

Examples: Herrick, *To the Lark*; Shakespeare, *Midsummernight's Dream* (Bottom's song).

The ráging rócks
And shívering shócks
Shall breák the lócks
Of príson gátes.

SHAKESPEARE.

Trochaic:

Examples: George Eliot, *The Spanish Gipsy*; Campion, *Art of Poesie*.

Coúld I cáтч that
Nímble traítor,
Scórnful Laúra,
Swíft-foot Laúra,
Soón then woúld I
Seék avéngement.

CAMPION.

Anapestic:

Examples: Shelley, *Arethusa*; Scott, *The Lady of the Lake* (Coronach).

He is góne on the moúntain,
He is lóst to the fórest,
Like a súmmer-dried foúntain,
When our neéd was the sórest.

SCOTT.

Dactyllic:

Examples: Tennyson, *Charge of the Light Brigade*; Longfellow, *Saga of King Olaf*.

Cánnon to ríght of them,
Cánnon to léft of them,
Cánnon in frónt of them,
Volleyed and thundered.

ONE-STRESS LINE

Iambic:

Example:

Thus **í**
Pass **bý**
And **díe**
As **óne**
Unkn**ó**wn
And **góne**.

HERRICK.

SEVEN-STRESS LINES (HEPTAMETER)

Iambic:

Examples: Howe, *Battle Hymn of the Republic*; Byron, *Stanzas for Music*; Kipling, *Wolcott Balestier*; Coleridge, *The Ancient Mariner*.

Mine **eyés** have **seén** the **glóry** **ó**f the **có**ming **ó**f the **Ló**rd.

HOWE.

THIS PAGE IS LOCKED TO FREE MEMBERS

Purchase full membership to immediately unlock this page

Know Your Bible

Forgotten Books' Full Membership provides unlimited access to more than 28,000 volumes of Christian literature for \$8.99/month

**HOLY
BIBLE**

Continue

*Fair use policy applies

Dactyllic:

Examples: Swinburne, *Hesperia*; Longfellow, *Evangeline*.

This is the fórest priméval; the múrmuring pínes and the hémlocks
Beárded with móss and with gárments greén, indistínt in the
twílight.

LONGFELLOW.

EIGHT-STRESS LINES

Iambic:

Example: William Wehbe, *Discourse of English Poetrie*.

Where vírtue wánts and více aboúnds, there weáldh is bút a
baítéd hoók.

Trochaic:

Examples: Tennyson, *Locksley Hall*; Poe, *The Raven*.

Ópen thén I fiúng the shútter, whén with mány a flírt and flútter,
In there stépped a stáately ráven óf the saíntly dáys of yóre.

POE.

Anapestic:

Example: Swinburne, *March*.

Ere fróst-flower and snów-blossom fáded and féll, and the spléndor
of wínter had pássed out of síght,
The wáys of the woódlands were faírer and stránger than dreáms
that fulfil us in sleép with delíght.

Dactyllic:

Example: Longfellow, *Golden Legend*, 4.

Ónward and ónward the híghway rúns to the dístant cíty, im-
pátiently beáring
Tídings of húman jóy and disáster, of lóve and báte, of dóing and
dáring.

FIVE-STRESS LINES (PENTAMETER)

Iambic (Heroic pentameter):

Examples: Milton, *Paradise Lost*; Bryant, *Thanatopsis*, etc., etc.

Sweet **A**úburn, lóveliest víllage óf the plaín
Where heá**l**th and bea**u**ty cheér the lá**l**aboring swa**í**n . . .
GOLDSMITH.

Trochaic:

Examples: Browning, *One word more*; Tennyson, *The Vision of Sin*.

Thén methó**u**ght I heá**l**d a mé**l**low so**u**nd,
Gá**l**thering **ú**p from á**l**l the ló**w**er gro**u**nd.

Anapestic:

Examples: Browning, *Saul*; Tennyson, *Maud*.

We have pró**v**ed we have heá**r**ts in a ca**u**se: we are nó**l**e st**í**ll.
TENNYSON.

Dactyllic:

Very rare in English.

While the remainder of the exercises in syllabication and graphic transcription, as described by Dr. Montessori, would seem to follow naturally on the above exercises in the analysis of line stress, it is clear that additional attention must be given to questions of terminology. For the metrical syntheses performed in the tables at the end of the preceding section will not be possible for English poetry unless the child is able to identify the kinds of feet and the kinds of lines. We suggest accordingly two supplementary drills with the card system familiar to the child from his exercises in grammar. The first consists of a list of words, each on a separate card,

with the tonic accent marked. Each word with its accent represents a foot (iambus, trochee, anapest, dactyl), indicated on the card in graphic transcription beneath the word:

wóndering
 ´ ˘ ˘

Corresponding to each word is another card bearing simply the graphic transcription and the name of the foot. The exercise, of the greatest simplicity, is to pair off the cards, arranging the words in a column on the table, putting after each the card that describes it. The cards, when properly arranged, read as follows:

betweén ˘ ´ iambus
 ˘ ´

móther ´ ˘ trochee
 ´ ˘

disrepúte ˘ ˘ ´ anapest
 ˘ ˘ ´

wónderful ´ ˘ ˘ dactyl
 ´ ˘ ˘

A second stage of this exercise consists in offering a similar series of cards where, however, the word-cards are without the indication of the tonic accent and without the graphic transcription of the measure:

suggest ˘ ´ iambus
 accent ´ ˘ trochee
 underneath ˘ ˘ ´ anapest
 metrical ´ ˘ ˘ dactyl

An identical exercise is possible for whole lines. The first stage consists of naming the lines accompanied by

THIS PAGE IS LOCKED TO FREE MEMBERS

Purchase full membership to immediately unlock this page

HISTORY

Tens of thousands of important historical sources, many previously unobtainable, are now available for the first time with a Forgotten Books Full Membership.

Unlimited Access
\$8.99/month

Continue

*Fair usage policy applies



APPENDICES

APPENDIX I

CHART FOR THE STUDY OF THE INDIVIDUAL CHILD

THIS PAGE IS LOCKED TO FREE MEMBERS

Purchase full membership to immediately unlock this page

Know Your Bible

Forgotten Books' Full Membership provides unlimited access to more than 28,000 volumes of Christian literature for \$8.99/month

HOLY BIBLE

Continue

*Fair use policy applies

DATA ON THE CHILD

Family Name.....*Names*.....

Date of Birth

Date of Entrance

Age of Parents: Father.....*Mother*.....

Occupations of Parents:

Father

Mother

Home Address

Personal History of the Child.....

.....

.....

.....

.....

Personal Appearance of the Child.....

Notes on Child's Family.....

.....

.....

.....

.....

.....

NameDate of Birth.....

.....

Date of Entering School.....

ANTHROPOLOGICAL NOTES

		HEAD (mm.)									
Stature (standing) (m.)	Weight (Kg.)	Thoracic circum. (m.)	Stature (sitting) (m.)	Index of Stature	Index of Weight	Circumference	Antero-post diameter	Transversal diameter	Cephalic Index		
.....
.....
.....
.....
.....
.....
.....
.....
.....
.....
.....

NOTES ON CHILD'S PHYSICAL DEVELOPMENT

SCHOOL YEAR 191..—191..

Name.....Date of Birth.....

MONTH	STATURE IN METRES		NOTES
	Standing	Sitting	
<i>September</i>
<i>October</i>
<i>November</i>
<i>December</i>
<i>January</i>
<i>February</i>
<i>March</i>
<i>April</i>
<i>May</i>
<i>June</i>
<i>July</i>
<i>August</i>

THIS PAGE IS LOCKED TO FREE MEMBERS

Purchase full membership to immediately unlock this page



HISTORY

Tens of thousands of important historical sources, many previously unobtainable, are now available for the first time with a Forgotten Books Full Membership.

Unlimited Access
\$8.99/month

Continue

*Fair usage policy applies

(Family Name)

(Names)

NAME IN FULL.....

SCHOOL YEAR 191..-191..

PSYCHOLOGICAL DIARY

<i>Diary</i>	<i>Name of child</i>	<i>Page Number</i>
<i>191..</i>	<i>Month</i>	<i>Day.....</i>

GUIDE FOR PSYCHOLOGICAL OBSERVATION

WORK.

NOTE:

When a child begins to show constant application to a piece of work.

What this work is and how long he remains at it (speed or slowness he shows in completing it, the number of times he repeats the same exercise).

Individual peculiarities in application to particular tasks.

To what tasks the child successively applies himself on the same day and with how much persistency to each.

Whether he has periods of spontaneous activity at work and on how many days.

How the child's need of progress is manifested by him.

What tasks he chooses and the order in which he chooses them; the persistency he shows in each.

His power of application in spite of distractions about him that might tend to divert him from his work.

Whether after a compulsory distraction he takes up again the task that has been interrupted.

CONDUCT.

NOTE:

Orderliness or disorderliness in the actions of the child.

The nature of his disorderliness.

Whether there are any changes in conduct as his working ability develops.

Whether, as his activities become more orderly, the child gives evidence of: accesses of joy; periods of placidity; expressions of affection.

The part the children take and the interest they show in the progress of their schoolmates.

OBEDIENCE.

NOTE:

Whether the child answers readily when he is called.

Whether and at what times the child begins to show interest in what others are doing and to make intelligent effort to join in their work.

The progress of his obedience to *calls*.

The progress of his obedience to *commands*.

What eagerness and enthusiasm the child shows in his obedience.

The relation between the various phenomena of obedience and (a) the development of his working capacity; (b) changes in conduct.

THIS PAGE IS LOCKED TO FREE MEMBERS

Purchase full membership to immediately unlock this page

Know Your Bible

Forgotten Books' Full Membership provides unlimited access to more than 28,000 volumes of Christian literature for \$8.99/month

**HOLY
BIBLE**

Continue

*Fair use policy applies

SCHOOL YEAR 191..-191..

PERSONAL HISTORY OF THE CHILD

BIOLOGICAL HISTORY

PARENTS:

Age of parents at marriage.....

Are the parents related to each other?.....

Sickness and diseases of the parents.....

.....

CHILD:

Were pregnancy and parturition normal?.....

.....

Was the nursing done by the mother, or artificially?.....

.....

The child's health during the first year:.....

.....

Subsequent sicknesses of the child:.....

.....

Date of teething, learning to walk, and learning to speak:.....

.....

.....

SCHOOL YEAR 191..-191..

SOCIAL HISTORY

FATHER:

Age, education and occupation:.....

.....

MOTHER:

Age, education and occupation:.....

.....

Are accounts kept in the family?.....

.....

Family habits (amusements, home life).....

.....

Number of persons in the family (how many adults, how many children)

.....

Does the family employ servants?.....

How many wage earners are in the family?.....

Does the family have income from property?.....

Does the family keep roomers or boarders?.....

Is the housekeeping satisfactory?.....

THIS PAGE IS LOCKED TO FREE MEMBERS

Purchase full membership to immediately unlock this page



HISTORY

Tens of thousands of important historical sources, many previously unobtainable, are now available for the first time with a Forgotten Books Full Membership.

Unlimited Access
\$8.99/month

Continue

*Fair usage policy applies

APPENDIX II

SUMMARY OF THE LECTURES ON PEDAGOGY DELIVERED IN ROME AT THE *SCUOLA MAGISTRALE ORTOFRENICA* IN 1900

This appendix contains a summary of a few of my lectures delivered in 1900 in the Scuola Magistrale Ortofrenica in Rome and published in pamphlet form for the benefit of the teacher-students who were attending that course. A number of distinguished physicians were at the same time lecturing in the school on various subjects — such as Psychology, Esthesiology, Anatomy of the Nerve Centres, etc. I had reserved for myself the teaching, or rather the development, of a special pedagogy for defective children, along the lines previously laid down by Itard and Séguin.

In the summary of these old lectures of mine are included some of my experiments with certain subjects taught in the elementary grades. They show that the origin of my present work with older and normal children is to be sought in my teaching of defectives.

I still possess, as documentary relics of this course, a hundred copies of a pamphlet entitled: *Riassunte delle lezioni di didattica della Prof^{ssa} Montessori, anno 1900, Stab. Lit. Romano, via Frattina 62, Roma.* More than three hundred teachers followed my course, and are able to bear witness to the work done there.

I republish the following excerpts not because I consider my work so important as to merit the preservation of

all the documents touching its origin, but to prevent the giving of undue prominence to those remnants of my earlier attempts and studies which are still to be found in the Scuola Magistrale Ortofrenica in Rome.

“The child should be led from the education of the muscular system to that of the nervous and sensory systems; from the education of the senses to concepts; from concepts to general ideas; from general ideas to morality. This is the educational method of Séguin.”

However, before we begin education, we must prepare the child to receive it by another education which is to-day regarded as of the very first importance. This preparatory education is the foundation on which all subsequent education must be based, and the success we obtain in it will determine the success of our subsequent efforts. By preparatory education I here mean *hygienic education*, which in defective children sometimes includes medical treatment. That is why the educational method for defectives is sometimes described as *medico-pedagogical*.

Those who realize the importance of feeling and internal sensation in education will understand that the bodily organism must function properly in order to respond to our educational efforts. We must preserve good health where good health exists; we must restore it where it is lacking.

We are therefore under strict obligation to pay close attention to nutrition and to the condition of the vital organs. Every one is aware of the close relation existing between general sensibility and morality. Criminals and prostitutes show very scant sensitiveness to pain and to tactile stimuli. The same situation is frequently apparent in defectives; hence the necessity of restoring the tactile sense with adequate attention to hygiene.

We cannot educate the muscles to perform a given coordinate movement if they have lost their power of functioning (as in paresis, etc.). Education, properly so-called, must be preceded by a medical treatment to restore the muscles, if possible, to good health.

It will be impossible to educate, for example, the sense of hearing, if some pathological situation has produced partial deafness. We cannot educate the sense of smell if the excessive excretion of mucus prevents external stimuli from acting on the ends of the sensory nerves. Obviously, we need a medical treatment to remove these diseased conditions.

MEDICAL EDUCATION

General baths: When not too prolonged they develop the sensibility of the nervous papillæ. They give tone to the cellular and muscular tissues, especially to the skin.

Hot and cold baths given alternately are a powerful educational instrument in attracting the attention of the child to his external environment.

Local hot laths may be given to areas deficient in sensibility. For instance, try bathing the hands if tactile education proves impossible, or bathe the feet if the defect in standing upright or in walking comes from the insensitiveness of the soles.

Local cold baths: Given to the head while the patient is entirely covered in warm water are a tonic to the scalp; they facilitate the knitting of the bones of the skull and the formation of wormian bones, preventing also cerebral congestion. They stimulate and regularize the cerebral circulation. Such baths are particularly useful for hydro-cephalics and micro-cephalics, but all patients are benefited by such baths, which are the most generally useful of all.

Steam baths develop perspiration which at times is completely absent or only partial in defectives, causing serious physical disturbances. These baths, furthermore, predispose the nerve ends to the most intense sensitiveness.

Such baths are, however, not to be used on epileptics or on children suffering from rickets, weak circulation or general debility.

In general, *local steam baths* are used especially for hands and feet, and also for the tongue.

General cold baths are used in cases of super-excitation, motor-hyperactivity, excessive sensitiveness to pain and touch. These baths must be accompanied by constant cold lotions on the head.

Baths may be accompanied, with goods results, by *massage* and *rubbing*.

Rubbings may be given either dry or with water, alcohol, aromatic creams or ointments.

Local rubbings may be applied: (a) *To the spine*, carefully avoiding the lumbar region so as not to excite the sexual sensibilities. Dry rubbings should be made with a piece of flannel and continued until the skin reddens. They are especially useful after hot baths followed by cold douches. (b) *To the chest* to stimulate respiration. (c)

THIS PAGE IS LOCKED TO FREE MEMBERS

Purchase full membership to immediately unlock this page

Know Your Bible

Forgotten Books' Full Membership provides unlimited access to more than 28,000 volumes of Christian literature for \$8.99/month

**HOLY
BIBLE**

Continue

*Fair use policy applies

These meals should be at regular hours, and followed without exception by a period of mental rest, which must be provided for in making up the daily program of lessons.

We need special researches as to what type of activity may be allowed children during digestion and what organs may be active without damage to the child while the stomach is taxed with the labor of digestion. A few things are clear. The children should be sent out of closed rooms where their play raises more or less dust, and kept in well-ventilated places, if possible, in a garden or in a woods well supplied with aromatic trees. The best thing a child can do immediately after a meal is to take a short walk in the open air without much exertion.

Quantity: In the case of children between 2 and 7 years of age, there should be two full meals and two luncheons. After the age of 7 there should be one lunch and two full meals. We cannot be more specific.

Quality: In the case of defectives it would be useful for the doctor to order a diet day by day after having examined the diaries of the nurses as is done in hospitals. For it may be possible to introduce into the food elements which constitute an actual cure for certain diseased conditions and preventives of certain kinds of attacks. In food we should realize the distinctions between the elements which build tissues — true food substances, and others whose function is purely stimulatory — alcohol, coffee, tea, etc., which should be used only occasionally.

Among the food substances properly so-called are the albuminoids (proteins), fats, and carbo-hydrates (sugars, starches, wheat and potato flours, etc.). The fats are the least digestible foods, but they produce the greatest number of calories.

The proportion of the different elements in the food should be determined by the amount of albumin, which constitutes the real food element. Albumin is of both vegetable and animal origin. Its animal forms are more nutritious, more easily digestible, and produce more calories than the vegetable forms. The foods which produce animal-albumin are milk, eggs, and meats. Vegetables themselves furnish what is known as vegetable-albumin. Children up to 6 years of age are supplied usually with the following albuminous foods: eggs, milk and

vegetables. For children between 6 and 8: eggs, milk, fish and vegetables may be provided. Older children may be given chicken, veal, and finally beef.

Though for normal children a restricted meat diet is desirable, in the case of defectives a rich supply of meat as well as of albuminoids in general is to be sought. Their treatment resembles that of weak convalescent patients whose strength is to be restored. The meats best adapted to such children are those containing large amounts of mucilaginous substances and sugar (veal, lamb and young animals in general). Vegetable *purées*, fat gravies, butter, etc., are to be recommended in these cases.

For *nervous children*, fats, oils, acids, and flours should be avoided.

For *apathetic children*, who experience difficulty in digestion, tonics and rich seasonings should be used, such as spices, which have come to be almost excluded from ordinary cooking, especially for children. Spices may well be restored to the diet of institutions for defectives, since they have the additional advantage of permitting mixture with irons, of which they neutralize the taste.

Questions of food depend largely upon the individual condition of the children. The important thing is to avoid "the school ration." This is all the more true of beverages.

Beverages: While stimulants are usually to be excluded from the diet of normal children of 7 or under, it is often desirable to introduce tea, coffee, etc., into the meals of defectives. This should be done, however, only in the daily diets ordered by the physician for individuals.

Nervous children should be restricted to milk and water for their meals with some moderately sweet drink (orange juice, weak lemonade, etc.) after eating.

Apathetics, showing atonic digestion, may have coffee either before eating or during their meals.

Special education is necessary to accustom the children to complete mastication. Such practice in the use of the organs of mastication assists also in the later development of speech.

EXCRETION

Among the physiological irregularities that appear among children special importance attaches to excretions.

Defecation: Among defectives especially, so-called "dirty children" are often so numerous that special sections have to be made for them in institutions. Such children show involuntary losses of fæces and urine, as in the case of infants. Most frequently the defecations are of liquid consistency though sometimes the reverse is true. Our remedial effort should be in two directions: we should try to regularize the operation of the intestines by giving solidity to the excretions; secondly, we should endeavor to strengthen the sphincter muscles.

A strict observance of the diet hygiene outlined above, especially as concerns regularity of meals and mastication of food, will assist in the attainment of the first object. We should try in addition to regularize defecation by stimulating it at regular intervals (to be gradually increased in length) through light massages and hot rubbings on the abdomen.

To strengthen the sphincters general tonics (iron, strychnine), and local tonics (such as cold "sitz-baths," cold showers and electric baths) may be used. Suppositories may also be used to advantage in stimulating sphincter contractions and accustoming the muscles to constrictive action.

Urine: Some defectives show involuntary loss of urine, especially at night, up to very advanced ages. Epileptics are particularly predisposed to this. The treatment is analogous to that just described. Beverages should be carefully supervised. Diuretics and excessive drinking in general should be avoided.

General recommendations: Local baths, and rigorous cleanliness to avoid any stimulus to onanism.

Education can do much in the treatment of this situation. Urination should be regularly suggested to the child before he goes to bed and when he wakes up in the morning. In special cases it might be well to waken the child once or twice during the night for the same purpose. This defect is often associated in a child with some abnormality in the phenomena of perspiration.

Perspiration: The sweat has almost the same composition as

THIS PAGE IS LOCKED TO FREE MEMBERS

Purchase full membership to immediately unlock this page

HISTORY

Tens of thousands of important historical sources, many previously unobtainable, are now available for the first time with a Forgotten Books Full Membership.

Unlimited Access
\$8.99/month

Continue

*Fair usage policy applies



ulate the sucking activity and the exercise of the contractive muscles. This will ultimately give the necessary muscular tone. The lips of the child should be closed mechanically from time to time to force him to swallow the saliva and to create the habit of deglutition.

CLOTHING AND ENVIRONMENT

The principles of hygiene must be extended to the dress of the child and to the environment in which it lives.

Clothing: The child's clothes should be so made as to be easily put on and off. They should not hinder the normal functioning of the body (breathing). They should afford no opportunity for dangerous vices (onanism). If the child can dress and undress without difficulty, it will learn the more readily to look after itself even in those little necessities of daily life where partial undressing is necessary. Special attention should be given to stockings, which affect the development of sensitiveness in the soles of the feet and also concern the process of learning to walk.

Environment: Just a few reminders: for defectives perfect ventilation of course; but the walls and furniture should be upholstered in the case of impulsive defectives or of defectives who do not know how to walk. There is danger in furniture with sharp projections and in toys which may be thrown about. A "child's room," the luxury of which consists in its hygienic location, its elastic walls, and its very emptiness, is the best gift a rich family can make to the education of a defective child.

MUSCULAR EDUCATION

Muscular education has for its object the bringing of the individual to some labor useful for society. This labor must always be executed by means of the muscles, whether it be manual labor, speaking or writing. In a word, the intelligence must subject the muscles to its own purposes and, that the muscles may be equipped for such obedience, it is necessary to prepare them by some education which will reduce them to coordination. Muscular education in defectives accordingly has for its object the stimulation and coordination of useful movements.

It prepares: for exercise; for the activities of domestic service (washing, dressing, preparing food, setting and clearing the table, etc.); for manual labor (trades); for language (use of the vocal organs). The preparation consists in bringing the child to *tonic quiescence* in standing posture. The child must learn first to stand still with head erect and with his eyes fixed on the eyes of the teacher. From this position of *tonic quiescence* we must pass to exercises in *imitation*. We obtain *tonic quiescence* by a variety of procedures, the variation depending upon individual cases. We must stimulate the apathetic and the sluggish; we must moderate the hyperactive; we must correct paresis, tics, etc. In other words, medical education must precede pedagogy itself. It may be a question of applying medical gymnastics both for active and passive movements, alternating this treatment with massage, electric baths, etc.

Let us note one or two motor abnormalities which are easy to detect in defectives. *Atony*: the child does not move; he cannot stand; he cannot sit upright nor execute any movement whatever. *Hyperactivity*: this is characterized by almost constant *incoordinated* or disorganized movements which have no useful purpose, e.g., jumping, beating, tearing up of objects within reach and so on. Such patients are dangerous to themselves and to others.

MECHANICAL MOVEMENTS

(A).—*Movements executed upon the person of the child*: sucking of the fingers; biting of the nails; constant stroking of some part of the body. These movements are caused by imperfectly developed sensibility; the children stroke or caress, for example, that area of the skin which possesses greatest tactile sensitiveness, etc.

(B).—*Movements executed upon surrounding objects*: rapping on tables; constant and careful tearing of pieces of paper into small bits, etc. This too is associated with some sensory pleasure on the part of the patient.

Rocking: (a) *with patient reclining*: the head is nodded from left to right, from right to left; (b) *with patient sitting*: the trunk is rocked backward and forward; (c) *with patient stand-*

ing: the whole body rocks from left to right, the whole weight resting now on one foot and now on the other. Difficulty and hesitation are experienced in walking. These motory defects proceed from the difficulty experienced by the child in finding his center of gravity, his equilibrium.

Inability to perform local movements: (a) Inability to move certain of the fingers, the tongue, the lips, etc. From such defects arises the impossibility of performing certain simple manual exercises (bringing the finger tips of the two hands together; taking hold of objects, e.g., inability to button, etc.) and the inability to pronounce certain words; (b) Inability to contract the lip and sphincter muscles (loss of saliva, involuntary defecation).

Atony and *hyperactivity* may be overcome by appropriate educational remedies which we will now discuss. Local agitations disappear with the general education of the senses; while rocking is cured by exercises in balancing.

(A).—*Stimulate active movements in the atonic child until he is able to stand erect in tonic quiescence.*

Begin by stimulating the simple movements, gradually working up to the most complicated. We have a sure guide for this education in the spontaneous developments of movements in the normal child: he begins with the easiest spontaneous movements and gradually arrives at the harder ones.

The first movement which develops in the child is the *prehensile* act (grasping). Next comes the movements of the lower joints used in creeping and walking; next the ability to stand; and finally the ability to walk alone. *Grasping*: if no external stimulation is capable of interesting the defective of low type, grasping cannot be stimulated merely by presenting to the child some object or other which might seem to be interesting for color, taste or some other quality. In such a case we must have recourse to the instinct of self-preservation, to that innate fear of void which defectives almost always have. The child feeling himself fall will instinctively grasp at some support within his reach. This is the simplest point of departure for our possible development of the grasping faculty in the defective child.

Method: The hands of the child are mechanically fixed around the rung of a ladder suspended to the ceiling. Then

THIS PAGE IS LOCKED TO FREE MEMBERS

Purchase full membership to immediately unlock this page

Know Your Bible

Forgotten Books' Full Membership provides unlimited access to more than 28,000 volumes of Christian literature for \$8.99/month

**HOLY
BIBLE**

Continue

*Fair use policy applies

our knees. Finally the child may be kept entirely quiescent with his legs held between the teacher's knees, his arms in the teacher's hands, with the trunk pushed back and held firmly against the wall. By a similar process he can be kept quiet while standing; then later in a position of *tonic quiescence*.

General Rule: Exercises of the limbs beginning with the arms should precede those specifically directed toward the spinal column. Séguin says "*tonic quiescence* is necessarily the first step from *atonic quiescence*; or if you wish, from a disordered activity to an activity which represents harmony between the muscular system and the mind."

We noted above that the posture of *tonic quiescence* involves a fixity of gaze on the part of the child. This is the point of departure for the development of coordinative movements and *imitation* of what the child sees the teacher do.

EDUCATION OF THE FIXED GAZE

If the child is kept in the dark for some time and is suddenly shown a bright light he will experience the sensation of *red*.

Keeping the child in a dark room for a shorter time a sudden light will attract his gaze.

Move the light along the wall until the child's gaze follows it.

Next, in a light room, the child is shown a red cloth kept in motion; a red balloon hung from the ceiling keeps striking him in the face.

After these preparatory exercises the teacher can try to get the child to fix its eyes on his own and to maintain the fixed gaze. Here use may be made also of the sense of hearing (words of command, encouragement, etc.).

Finally to obtain complete fixity of gaze, one may use the large mirror, before which lights may be passed. There the child can gaze at his own face and at the face of the teacher, which will be kept motionless and which the child may come to imitate.

Exercises of imitation: (1) The child is taught to become acquainted with himself. The various parts of his body are pointed out to him and he is made to touch them. This continues up to the point of distinguishing right from left. Be-

gin with the larger members of the body (arms, legs, trunk, head) to be named in connection with movements of the whole body. Then pass to the smaller members (the fingers, knuckles, the organs of the mouth), to be referred to respectively in the education of the hand and in the teaching of speech.

(2) The child is taught coordinative movements relating to gymnastics (walking, running, jumping, pushing, etc.).

(3) Movements relating: (a) to the simpler forms of manual labor (exercises of practical life: washing, dressing, picking up and laying down various objects, opening and closing drawers); (b) to more complex kinds of manual labor (elements of various trades; weaving, Froebel exercises, etc.).

(4) Movements relating to articulate language. For this educational process the following general rules are to be followed: first, movements of the whole body must precede movements of specific parts; second, only by analyzing complex movements in their successive stages and by working out their details point by point can we arrive at the execution of a perfect complex movement.

This latter rule applies especially to manual education and the teaching of language. When movements of the whole body have been obtained it will often be necessary, before going on to movements of particular members, to alternate the educational cure with the medical: (1) to overcome the weakness of some of the muscles (perhaps of some finger), use local electric baths, passive gymnastics, etc.; (2) for retractions, retarded development of aponeurosis of the palms, etc., use orthopedic treatment.

Gymnastics, manual labor, trades and speaking are special branches of teaching, that usually require specially trained teachers.

EDUCATION OF THE SENSES

Outline for examination.

Sight: Sense of color. It is necessary to call the attention of the child several times to the same color by presenting it to him under different aspects and in different environments. The stimulus should be strong. Other senses tend to associate themselves with the chromatic sense, for example, the stereognostic and gustatory senses. Whenever the teacher gives an

idea she should unite with it the *word*, the only word which is related to the idea. The words should be emphatically and distinctly pronounced.

(1) *Pedagogical aprons*: The colors are presented on a large moving surface, as for instance, an apron worn by the teacher; e.g., a red apron. The teacher points to it, touches it, lifting it with noticeable movements of the arms, continually calls the attention of the child to it. “*Look! See here! Attention!*” and so on; then saying in a low voice and slowly, “*This is* (and then in a louder voice), *red, red, red!!!*” Now take two aprons, one red, the other blue; repeat the same process for the blue. There are three stages in the process of distinguishing between colors: (a) “*This is . . . red!*” (b) “*Your apron is red!*” (c) “*What color is this?*” Then try three aprons, red, blue, and yellow, bordered with white and black.

(2) *Insets* — color and form. The red circle, the blue square. There are three stages: (a) “*This is red, red, red!*” Touch it! Do you feel? Your finger goes *all the way around, all the way around*. It is *round, it is round, all round*. Put it in its place!” (b) “*Give me the red one!*” (c) “*What color is this circle?*”

(3) The dark room. A Bengal red color is shown: “*It is red!*” The color appears behind a circular disc: “*It is red!*” The blue is shown behind a square window: “*It is blue, blue, blue,*” etc.

(4) The child is given a circular tablet of red sugar to eat and a square lump of blue sugar. He is made to smell a red piece of cloth strongly scented with musk; or a blue piece of cloth scented with asafetida, etc.

(5) The color chart.

(6) The first game of Froebel.

The first pedagogical material given should contain the color already taught. The notion of color should be associated with its original environment.

Shapes: Solids, Insets: The procedure is always in the three stages mentioned. (1) Show the object to the child. (2) Have him recognize it. (3) Have him give it its name.

Dimensions: Rods of the same thickness, but of graduated length. First the longest and the shortest are shown. The

THIS PAGE IS LOCKED TO FREE MEMBERS

Purchase full membership to immediately unlock this page



HISTORY

Tens of thousands of important historical sources, many previously unobtainable, are now available for the first time with a Forgotten Books Full Membership.

Unlimited Access
\$8.99/month

Continue

*Fair usage policy applies

Olfactory sense: Asafetida, oil of rose, mint, etc.,

Odors of	{	Tobacco smoke	}	Various applications to practical life.
		Burned sugar		
		Incense		
		Burned maple		
Odors of burning substances	{	Wood	}	Various applications to practical life.
		Straw		
		Paper		
Guessing Games	{	Wool	}	Various applications to practical life.
		Cotton		
		Edibles		

Odors of foods (practical life): fresh milk, sour milk, fresh meat, stale meat, rancid butter, fresh butter, etc.

Taste: The four fundamental tastes (guessing games). Instructive applications to practise in the kitchen and at meals.

Tastes of various food substances:

Exercises of practical life	{	milk gruel (milk and flour);	}
		diluted wine;	
		sweet wine;	
		turned wine (vinegar), etc.	

The practise of the senses begins in the lower classes in the form of guessing games; in the higher classes the education of the senses is applied to exercises of practical life.

Hearing: Empirical measurement of the acuteness of the sense of hearing. Specimen game: the teacher about 35 feet away from the blindfolded children and standing where an object has been hidden, whispers the words "*Find it!*" Those who have heard her will be able to find the object. Having removed from the line the children who have heard, the teacher steps to another place about a yard nearer and repeats the experiment to the children who are left over, etc.

Intensity of sound:

Throw to the floor metal blocks of various sizes, coins of graduated weight.

Strike glasses one after the other according to size.

Bells of graduated size.

Quality of sound: Produce different sounds and noises.

Bells { of metal
of terracotta

Open Bells.

Closed Bells.

Strike with a wooden stick on tin plates, glasses, etc.

Identify various musical instruments.

Identify different human voices (of different people).

Identify the voice of a man, a woman, a child.

Recognize different people by their step, etc., etc.

Pitch: Intervals of an octave, of a major triad, and so on; major and minor chords. However, musical education requires a separate chapter.

Sound projection, localization of sound in space: The child is blindfolded. The sound is produced: (1) in front of him; behind him; to the right; to the left; above his head; (2) the blindfolded child recognizes the relative distance at which the sounds are produced; (3) the child decides from which side of the room the sounds come; he is made to follow some one who is speaking.

The horizontal plane: This is the first notion imparted to the child concerning his relationship to the objects about him. Almost all the objects the child may perceive around him with his senses rest on the horizontal plane: his table, his chair, and so on. The very objects on which the child sits or puts his toys are horizontal planes. If the plane were not horizontal, the objects would fall, but they would strike on the floor which, again, is a horizontal plane. Place an object on the child's table and tip one end of the table to show him that the object falls.

Guessing game for the plane surface: This game serves to fix the notion of the plane surface and at the same time trains the eye and the attention of the child.

1. Under one of three aluminum cups is placed a small red ball, a cherry or a piece of candy. The child must remember under which cup the object is hidden. The teacher tries herself and fails, always raising the empty cups and returning them to

their places. The child, however, finds the object immediately.

2. The teacher now begins to move the three cups about on the plane surface. The child has to keep his eye on *his* cup and never loses sight of it.

3. Repeat this exercise with six cups.

Checkerboard game: This serves to teach the child the limits and the various divisions of a plane. The squares are large and in black and white. The whole board should be surrounded by a border in relief. Various points are indicated on the plane: forward, backward, right, left, center, by placing a tin soldier at each point indicated. The soldiers may be moved about by the child in obedience to directions of the teacher: "The officer on horseback to *the center*": "Standard-bearer to *the right*, etc.!" Finally, make all the soldiers advance toward the center of the board over the black squares only; then over the white squares only, etc.

These notions may be applied to exercises of practical life. The children already know how to set the table without thinking of what they are doing. From now on, the teacher may say: "Put the plates on the *plane surface* of the tables!" "Put the bottle to *the left*! *In the center*!" etc. Have a small table set with little dishes, having the objects arranged in obedience to commands of the teacher. After this, we may proceed to the Froebel games on the plane surface with the cubes, blocks, and so on.

Inset game as a preparation for reading, drawing, and writing: After the child knows the different colors and shapes in the inset, the color tablets of the big inset can be put in place: (1) on a piece of cardboard where the figures have been drawn in shading in the respective colors; (2) on a cardboard where the same figures have been drawn merely in colored outline (linear abstraction of a regular figure).

Inset of shapes where the pieces are all of the same color (blue): The child recognizes the shape and puts the pieces in place: (1) on a cardboard where the figure is shaded; (2) on a cardboard where the figure is merely outlined (linear abstraction of regular geometrical figures). Meanwhile, the child has been touching the pieces: "The tablet is smooth. It turns round and round and round. It is a *circle*. Here we have a

THIS PAGE IS LOCKED TO FREE MEMBERS

Purchase full membership to immediately unlock this page

Know Your Bible

Forgotten Books'
Full Membership
provides unlimited
access to more than
28,000 volumes of
Christian literature for
\$8.99/month

**HOLY
BIBLE**

Continue

*Fair use policy applies

letter there are painted one or more figures of objects, the names of which begin with the letter in question. Beside the long-hand letter, there is also painted in the same color a smaller letter in print type. The teacher, naming the consonants in the phonic method, points to the letter, then to the chart, pronouncing the name of the objects which are painted there, and stressing the first letter: e.g., "m . . . man . . . m: Give me *M!*" "Put it where it belongs!" "Follow around it with your finger!" Here the linguistic defects of the children may be studied.

The tracing of the letters in the way they are written begins the muscular education preparatory to writing. One of our little girls of the motory type when taught by this method reproduced all the letters in pen and ink long before she could identify them. Her letters were about eight millimetres high and were written with surprising regularity. This same child was generally successful in her manual work.

The child, in looking at the letters, identifying them, and tracing them in the way they are written, is preparing himself both for reading and writing at the same time. The two processes are exactly contemporaneous. Touching them and looking at them brings several senses to bear on the fixing of the image. Later the two acts are separated: first looking (reading), then touching (writing). According to their respective type, some children learn to read first, others to write first.

Reading: As soon as the child has learned to identify the letters and also to write them, he is made to pronounce them. Then the alphabet is arranged in phonetic order. This order is to be varied according to individual defects made apparent while the child is pronouncing spontaneously the sounds of the consonants or vowels, or the words illustrating the consonants on the charts. We begin by showing the child and having him pronounce, first, syllables and, then, words which contain the letters he is able to pronounce well. Then we go on to the sounds he has trouble with, finally to those he cannot pronounce at all (linguistic correction). The phonomimic correction of speech requires special discussion. In primary schools speech correction should be in the hands of a specially trained teacher, like gymnastics, manual training and singing. Should no de-

fects in speech appear in the child, the letters of the alphabet should be taught in the order of physiological phonetics.

Beside the big long-hand letters should be placed the small letters in print type. The letter is taught; then recognition is prompted by asking as each large letter is reached: "I want the little one like it." The two types of letter appear also on the illustrated charts. Next the printed letter is shown, with the request: "Give me the big letter that goes with it." Finally: "What letter is it?" The little letters are not "touched," because they are never to be written.

DRAWING AND WRITING

The child is given a sheet on which appear a circle and a square in outline. The circle is filled in with a red pencil, the square with blue (insets). Smaller and smaller circles are next given, also circles and triangles. They are variously disposed on the page. They are to be filled in with colored pencils. Then comes the tracing. The black lines are followed around with colored pencils: the circle, the triangle, the square. This comes easily to the child who has been taught to trace with the wooden skewer the figures outlined on the inset-charts. Writing follows immediately on the exercises in tracing with the skewer on the charts of the written alphabet. Some help can be given the child by having him darken with a black pencil the letter written on the copy book by the teacher. As the child writes, his attention should be directed to the fact that he is writing on a *limited plane surface*; that he begins at the top, moving from left to right and little by little coming down the page.

Séguin's method began with shafts and curves. His copy-books for the shafts were prepared as follows: the shaft to be executed by the child was delimited by two points, connected by a very light line. In the margin of the pages appear two shafts to be executed by the teacher. Similarly for the curves: ((((. He has the printed capitals drawn as combinations of shafts and curves: B, D, etc.

SIMULTANEOUS READING AND WRITING OF WORDS

The child, through sensory education, has acquired some notions of color, shape, surface (smooth and rough), smell, taste, etc. At the same time, he has learned to count (one, two, three, four points). Uniting all possible notions concerning a single object, we arrive at his first concrete idea of the object itself: the object lesson. To the idea thus acquired, we give the *word* which represents the object. Just as the concrete idea results from the assembling of acquired notions, so the word results from the union of known sounds, and perceived symbols.

Reading lesson: On the teacher's table is the large stand for the movable alphabet in black printed letters. The teacher arranges on it the vowels and a few consonants. Each child, in his own place, has the small movable alphabet in the pasteboard boxes. The children take from the box the same letters they see on the large stand, and arrange them in the same order. The teacher takes up some object which has a simple word for a name, e.g., *pane* ("bread"). She calls the attention of the child to the object, reviewing an objective lesson already learned, thus arousing the child's interest in the object. "Shall we write the word *pane*?" "Hear how I say it!" "See how I say it!" The teacher pronounces separately and distinctly the sounds of the letters which make up the word, exaggerating the movements of the vocal organs so that they are plainly visible to the children. As the pupils repeat the word they continue their education in speaking.

A child now comes to the teacher's desk to choose the letters corresponding to the sounds and tries to arrange them in the order in which they appear in the word. The children do the same with the small letters at their seats. Every mistake gives rise to a correction useful to the whole class. The teacher repeats the word in front of each one who has made a mistake, trying to get the child to correct himself. When all the children have arranged their letters properly, the teacher shows a card (visiting-card size) on which is printed (in print-type letters about a centimeter high) the word "*pane*." All the children are made to read it. Then some child is asked to put the card where he finds the word written before him; next, on

THIS PAGE IS LOCKED TO FREE MEMBERS

Purchase full membership to immediately unlock this page



HISTORY

Tens of thousands of important historical sources, many previously unobtainable, are now available for the first time with a Forgotten Books Full Membership.

Unlimited Access
\$8.99/month

Continue

*Fair usage policy applies

ing, animals, people, etc. There should be a box for *adjectives* with compartments for *colors, shapes, qualities, etc.* There should be another for *particles* with compartments for *articles, conjunctions, prepositions, etc.* A box should be reserved for *actions* with the label *verbs* above; and then in it a compartment should be reserved for the *infinitive, present, past and future* respectively. The children gradually learn by practice to take their cards from the boxes and put them back in their proper places. They soon learn to know their "word boxes" and they readily find the cards they want among the *colors, shapes, qualities, etc.,* or among *animals, foods, etc.* Ultimately the teacher will find occasion to explain the meaning of the big words at the top of the drawers, *noun, adjective, verb, etc.,* and this will be the first step into the subject of *grammar.*

GRAMMAR

NOUN LESSON

We may call persons and objects by their *name* (their *noun*). People answer if we call them, so do animals. Inanimate objects, however, never answer, because they cannot; but if they could answer they would; for example, if I say *Mary*, *Mary* answers; if I say *peas*, the *peas* do not answer, because they cannot. You children *do* understand when I call an object and you bring it to me. I say for example, *book, beans, peas.* If I don't tell you the name of the object you don't understand what I am talking about; because every object has a different name. This name is the word that stands for the object. This name is a *noun*. When I mention a noun you understand immediately the object which the noun represents: *tree, chair, pen, book, lamb, etc.* If I do not give this noun, you don't know what I am talking about; for, if I say simply, *Bring me . . . at once, I want it,* you do not know what I want, unless I tell you the name of the object. Unless I give you the *noun*, you do not understand. Thus every object is represented by a word which is its *name* and this name is a *noun*. To understand whether a word is a noun or not, you simply ask "Is it a thing?" "Would it answer if I spoke to it?" "Could I carry it to the teacher?" For instance, *bread.* Yes, *bread* is an object; *table,*

yes, it is an object; *conductor*, yes, the conductor would answer, if I were to speak to him.

Let us look through our cards now. I take several cards from different boxes and shuffle them. Here is the word *sweet*. Bring me *sweet*. Is there anything to answer when I call *sweet*? But you are bringing me a piece of candy! I didn't say *candy*: I said *sweet*! And now you have given me sugar! I said *sweet*. If I say *candy*, *sugar*, then you understand what I want, what object I am thinking about, because the words *candy*, *sugar*, stand for objects. Those words are *nouns*. Now let us look through the noun cards. Let us read a couple of lines in our reading books and see whether there are any nouns there. Tell me, are there any nouns? How are we to find some nouns? Look around you! Look at yourself, your clothes, etc.! Name every object that you see! Every word you thus pronounce will be a noun: Teacher, clothing, necktie, chair, class, children, books, etc. Just look at this picture which represents so many things! The figures represent persons and objects. Name each of these figures! Every word you pronounce will be a noun!

VERB: ACTION

Mary, rise from your seat! Walk! Mary has performed a number of *actions*. She has *risen*. She has performed the *action* of rising. She has *walked*. *Walk* stands for an action. Now write your name on the blackboard! *Writing* is an action. Erase what you have written. *Erasing* is an action. When I spoke to Mary, I performed the action of speaking. (Just as the noun was taught with objects, here we must have actions. Objects represented in pictures will be of no use, since actions cannot be portrayed by pictures.)

The next step will be to suggest a little exercise of imagination. Look at all these objects! Try to imagine some action which each might perform! A *class*, for instance; what actions might a class perform? *Store*: what actions might take place in a store? Let us now look through our cards after we have shuffled them. Next try our reading book. Show me which of the words are verbs. Give me some words which are verbs (infinitive).

NOUN

Persons, things (proper and common nouns). Singular, plural, masculine and feminine. The articles: "Choose the article that goes with this noun!" etc.

VERB

Present, past, future. I am performing an action now. Have I performed it before? Did I do it yesterday? Have I always done it in the past? When I walk now, I say I *am walking*, I *walk*. When I mean the action that I performed yesterday, I say: I *was walking*, I *walked*. The same action performed at different times is described differently. How strange that is! The word referring to an object never changes. The beads are beads to-day. They were beads yesterday. *Actions*, however, are represented by words which change according to the time in which they are performed. To-day I *walk*. Yesterday I *walked*. To-morrow I *shall walk*. It is always *I* who do the walking, *I* who perform the *action* of walking; and I walk always in the same way, putting one foot in front of the other. The objects you see perform an action always perform it. Do you see that little bird which is flying—which is performing the *action* of flying? It was flying yesterday. It flew at some time in the past. To-morrow also, that is, at some *future* time, if the little bird lives, it will fly and it will fly always in the same way, beating its wings to and fro. You see what a strange thing a verb is! It changes its words according to the *time* in which the action is performed. It is different according as it represents action in *present* time, or action in *past* time, or action in *future* time. Now, see! I am going to take out some of my cards and make up a little sentence:

Now	George	eats	an	apple
-----	--------	------	----	-------

Now I am going to change the word which stands for the time when the action takes place. In place of the card *now* I am going to use this one:

THIS PAGE IS LOCKED TO FREE MEMBERS

Purchase full membership to immediately unlock this page

Know Your Bible

Forgotten Books' Full Membership provides unlimited access to more than 28,000 volumes of Christian literature for \$8.99/month

HOLY BIBLE

Continue

*Fair use policy applies

but always with the *object*. All the notions possessed by the child should be as far as practicable in a given case applied to his study of the object. First it should be described as to its qualities; next as to its uses, then as to its origin; for example, Here is an *object*! What color is it? What is its shape? Feel of it! Taste of it! etc. If possible, have the child see the use of the object and its origin in every possible way. Just as the concrete idea of the object is imparted by verbal description and by various appeals to the senses of the child, so the different uses of the object should be brought out in *describing actions* which the child sees performed with it before him. This, of course, is an ideal which the teacher should try to realize as far as possible. The object should be shown the child in different circumstances and under different aspects so as to give it always the appearance of something new and something to excite and hold the attention of the child. Take, for instance, a lesson on the word *hen*. Show a paper model of the hen, the live hen in the courtyard, the stereopticon slide of the hen: the print of the hen in the reading book: the hen alive among other domestic fowls; pictures of the hen among pictures of other birds, etc. Each new step should be taken on a different day and each time the word should be connected with the object. Write the word on the blackboard; make up the printed card for the card file and put it in its proper box. "Who wants to take the blackboard out-doors? We are going to write some words in the yard. Now in your reading books there is the figure of the hen. Next to it is the word *hen*. Write this word in your copy books. Who can repeat what we have said about the hen? Write down what you know about the hen." The amount of information given about a particular object will depend, of course, upon the class. The simplest description should be followed by one more minute, passing thus to speak of uses, habits, origin, etc. The writing of a simple word may be developed into a written description. But the lessons on the given object should always be short, and they should be repeated on different days. For the lessons on trees, plants, and vegetables, a garden is necessary: the children should see the seeds planted, a growing vegetable, a picture of the fruit, etc. If possible the domestic use of the garden

products should be demonstrated. This applies also to flowers. The blackboard with crayon should never be lacking in the garden. For object lessons we need toys to represent furniture, dishes, various objects used in the home, tools of different trades, rooms and the furniture that goes in each, houses, trees, a church (to build villages), etc.; dolls equipped with all the necessaries for dressing. There should be a shelf for bottles containing specimens of different drinks; various kinds of cloths (for tactile exercises); the raw materials out of which they are made, demonstrations of the way they are manufactured, etc. Show also specimens of the various minerals, etc.

HISTORY

History is taught first on a little stage with living tableaux, gradually advancing to action; second, by descriptions of large illustrations and colored pictures; third, by story-telling based on stereopticon views. The teacher should strive for brevity, conciseness, and vivacity in descriptions. Historical story telling should, as in the case of all other lessons, bring about additions of printed cards to the word boxes. Various information on the seasons, months of the year, etc., should be imparted by illustrations and pictures. Every morning the child should be asked: "What day is it? What day was yesterday? What day will to-morrow be?" and "What day of the month is it?"

GEOGRAPHY

1. Exercises on the plane for the cardinal points, with various gymnastic and guessing games.
2. Building games out of doors. Make a lake, an island, a peninsula, a river.
3. Carry the houses and church into the yard and construct a small village. Put the church on the north; the schoolhouse on the east; the mountain on the west; in front of the school place the national flag.
4. In the classroom fit out a room with its proper furniture to be placed on a map of the room outlined on a large chart. As the furniture is removed, make a mark on the map to indicate where each article was. Make a little village in the same way, houses, church, etc. Take away the church, etc.; mark the place of each object on the map as it is

removed. Then identify each spot. "Where was the church?" "What was over here?" etc. Thus we get a conception of the geographical map. Read the map, making use of the cardinal points. 5. Physical characteristics of regions may be shown by clay modeling to represent hills, etc. Draw outlines around each model, remove the clay and read the *geographical map* resulting.

ARITHMETIC

The children are to count: 1 nose; 1 mouth; 1, 2 hands; 1, 2 feet; 1, 2, 3, 4 points in the insets; 1, 2, 3, 4, 5, 6 soldiers on the plane. How many blocks did they use in the building? 1, 2, 3, 4, 5, 6, 7, 8, 9. Thus for the elementary steps in counting.

COMPUTATION

Computation should be taught practically in the store from the very beginning. The shopkeeper sells 1 cherry for 1c. The children have 2c and get two cherries. Next they get two nuts for 1c. Place 1c on the counter and place 2 nuts beside it. Then count all the nuts and there are 2 for 1c, etc. The child wants one cherry and has a two-cent piece. The shopkeeper must give him 1c in change ($2 + 2 = 4$; $2 - 1 = 1$). In money changing it will be observed that at first some children recognize the coins more easily by touch than by sight (motor types).

WRITTEN NUMBERS

Charts with the nine numbers: one for each number. Each chart has pictures representing quantities of the most varied objects arranged around the number, which is indicated by a large design on the chart. For instance: on the 1 card there is one cherry, one dog, one ball, etc. Yesterday the shopkeeper sold one cherry for 1c. Is the cherry here? Yes, there is the cherry! And what is this? *One* church! And this? *One* cent! etc. What is this figure here? It is the number *one*. Now bring out the wooden figure: What is this? Number *one*! Put it on the figure on the chart! It is *one*.

Now take the charts to the store. Who has 1c? Who has

THIS PAGE IS LOCKED TO FREE MEMBERS

Purchase full membership to immediately unlock this page



HISTORY

Tens of thousands of important historical sources, many previously unobtainable, are now available for the first time with a Forgotten Books Full Membership.

Unlimited Access
\$8.99/month

Continue

*Fair usage policy applies

The child places the movable numbers and the cubes on the figures on the charts. The teacher then makes two equal rows of cubes to correspond to the even numbers (red). The division is easy! But try to separate the odd numbers (blue). It is not possible! A block is always left in the middle! The child takes the figures and the blocks and arranges them on his table, imitating the design on the chart. He tries to make two equal rows of cubes for the even numbers. He succeeds. He does not succeed in doing so with the odd numbers. The numbers which can be divided thus are *even*; those which cannot be so divided are *odd*.

Number boxes: On these boxes are designed red and blue figures identical with those on the charts. The child puts into each box the number of cubes called for by the figure on the box. This exercise follows immediately the work on odd and even numbers described above. As the child transfers each series of cubes from his table to the boxes, he pronounces the number and adds *odd* or *even*.

Exercises in attention and memory: A chart of odd and even numbers in colors is placed on the teacher's desk in view of all the children. The red and blue cubes are piled on the teacher's desk. The teacher passes the wooden figures to the children and tells them to examine them. Immediately afterwards the children leave their seats, go to the teacher's desk, and get the numbers which correspond to their own figures. On going back to their places they fit the cubes under the corresponding figure in the arrangement just learned. The teacher is to observe

1. Whether the child has remembered the color of his figure (frequently a child with a red number takes the blue cubes).
2. Whether he has remembered his *number*.
3. Whether he remembers the proper arrangement.
4. Whether the child remembers that the chart from which he *can copy* is before him on the stand and whether he thinks of looking at it.

When mistakes are made, the teacher has the child correct himself by calling his attention to the chart.

COUNTING BY TENS

(For more advanced classes)

In the store ten objects are sold for one cent, e.g.:

(10 beans), one cent for each *ten*.

One ten = ten, 10.

Two tens = twenty, 20.

Three tens = thirty, 30, etc.

From forty on (in English from sixty on) the numbers are more easily learned because their names are like simple numbers with the ending *-ty* (Italian-*anta*).

Charts should be prepared (rectangular in shape) on which nine tens appear arranged one under the other; then nine cards where each ten is repeated nine times in a column; finally, numerous cards with the unit figures 1, 2, 3, 4, 5, 6, 7, 8, 9, to be fitted on the zeros on the cards where the tens are repeated nine times.

10 — 10 — 20

20 — 10 — 20

30 — 10 — 20

40 — 10 — 20

50 — 10 — 20

60 — 10 — 20

70 — 10 — 20

80 — 10 — 20

90 — 10 — 20

Some difficulty will be experienced with the tens where the names do not correspond to the simple numbers: 11, 12, 13, etc. The other tens, however, will be very easy. When a little child is able to count to 20, he can go on to 100 without difficulty. The next step is to superimpose the little cards on the first chart of the tens series, having the resultant numbers read aloud.

Problems: Problems are, at first, simple memory exercises for the children. In fact the problems are solved practically in the store in the form of a game; buying, lending, sharing with their schoolmates, taking a part of what is bought and giving

it to some other child, etc. The store exercises should be repeated in the form of a problem on the following morning. The children have simply to remember what happened and reproduce it in writing. *Problems are next developed contemporaneously* with the various arithmetical operations and computations (addition, multiplication, etc.). The teacher explains the operations starting with the problem, which becomes for the children a very amusing game. The problem, finally, becomes an imaginative exercise: "Suppose you are going to the store to buy," etc., etc. We can ultimately arrive at real problems that require reasoning. In the store the teacher illustrates the various operations on the blackboard, using simple marks at first: "You have bought 2c worth of beans, at three for a cent. Let us write that down: III—III. Then let us count.

III III

1, 2, 3, 4, 5, 6. There are six. Well, then, $3 + 3 = 6$. We can also say: 2 groups of III equals 6; twice, three, six; two times three, six; $2 \times 3 = 6$. How much is $3 + 3$? How much is 2×3 ? How much is 3×2 ?"

The following morning, when the written problem is given, the child should have before him for reference the computation charts with all the combinations possible.

The transition to mental computation will come after this and not before.

SAMPLE CARDS

(Addition)

$1 + 1 = 2$

$2 + 1 = 3$

$3 + 1 = 4$

$1 + 2 = 3$

$2 + 2 = 4$

$3 + 2 = 5$

$1 + 3 = 4$

$2 + 3 = 5$

$3 + 3 = 6$

$1 + 4 = 5$

$2 + 4 = 6$

$3 + 4 = 7$

(Multiplication)

$1 \times 1 = 1$

$2 \times 1 = 2$

$3 \times 1 = 3$

$1 \times 2 = 2$

$2 \times 2 = 4$

$3 \times 2 = 6$

$1 \times 3 = 3$

$2 \times 3 = 6$

$3 \times 3 = 9$

THIS PAGE IS LOCKED TO FREE MEMBERS

Purchase full membership to immediately unlock this page

Know Your Bible

Forgotten Books' Full Membership provides unlimited access to more than 28,000 volumes of Christian literature for \$8.99/month

**HOLY
BIBLE**

Continue

*Fair use policy applies

fix ideas, lessons should be repeated many times. Each time, however, the same objects should be presented under different forms and in a different environment, so that it will always be interesting by appearing as something new: story-telling, living tableaux, large illustrations; colored pictures; stereopticon views, etc. In case individual teaching is necessary, as happens in the most elementary classes, care should be exercised to keep all the other children busy with different toys: insets, lacing-and-buttoning-frames, hooks and eyes, etc. When children refuse to take part in their lessons it is better not to use coercion, but to aim at obtaining obedience indirectly through the child's imitation of his schoolmates. Glowing praise of the pupils who are showing good will in their work almost always brings the recalcitrants to time. When a child shows he has understood the point under discussion, it is better not to ask for a repetition. His attention is easily fatigued, and the second time he may say badly what at first he gave successfully; and the failure may discourage him. It is well to be satisfied with the first good answer, bestow such praise as will afford the child a pleasant memory of what he has been doing; and go back to the subject on the following day, or, at the earliest, several hours later.

In manual training, however, the situation is different. The lesson in this subject can be a whole hour long and should take the form of serious work and not of play. The child should be set early at some useful task, even if a little hard work, not unattended with risk, be involved (wood-cutting, boring, etc.). From the outset, thus, the child will become familiar with the difficulties of bread-winning effort and will learn to overcome them.

Interest in work may be stimulated by appropriate rewards. The child may earn during work-hours the money for his purchases at the store, for his tickets to the theater and the stereopticon lecture. The child who does not work may be kept away from the more attractive lessons, such as dancing and music, which come immediately after the work hour. As a matter of fact, these children take to manual training very readily, provided the tasks assigned are adapted to the natural inclinations of the individual child in such a way that he may

take in his work the greatest possible satisfaction and thus by natural bent attain a skill useful to himself and society.

MORAL EDUCATION

By the expression "moral education" we mean an education which tends to make a social being of an individual who is by nature extra- or anti-social. It presents two aspects which may be paralleled with the education thus far treated and which we call "intellectual education."

In this latter training of the mind, we began by an appropriate hygienic cure of all those physical defects which could stand in the way of successful mental education. In moral education, likewise, we try to eliminate such defects as arise from some passing physical ailment. We should carefully consider the apparently causeless "naughtiness" of children, to see whether it may not be due to some intestinal disturbance, or to the early stages of some infectious disease. The symptoms of such diseases should be known to the teacher. I have been told that English mothers use the empirical method of administering purgatives or cold shower baths to "naughty children," often with good correctional effect. I suggest that such empiricism is hardly prudent where science is able to prescribe much safer and more efficacious methods. Child hygiene must be well known to the educator and should be the pivotal point of every educational system.

In mental education, we began by reducing the child to *tonic quiescence*; here we must begin by reducing the child to *obedience*.

In mental education, to give the child his first notions of his physical person (personal imitation: touching of the parts of the body) and of his relations to environment (personal imitation: moving of objects, etc.) we had recourse to *imitation*; here, to instil in the child elementary notions of his duties, we must throw around the child an atmosphere morally correct, an environment in which, after attaining obedience, he can *imitate* persons who act properly.

In mental education we went on to the training of the senses; here we pass to the education of *feelings*. Our next step, in

the one case, was to the education proper of the mind; here it is to the training of the will.

The parallel is perfect:

hygienic training: hygiene;

tonic quiescence: obedience;

imitation: imitation (environment);

sensory education: education of the feelings (sensibilities);

mental education proper: education of the will.

OBEDIENCE

In a command the will of the teacher is imposed upon the defective child who is lacking in will. The will of the teacher is substituted for the child's will in impelling to action or inhibiting the child's impulses. From the very first the child must feel this will, which is imposed upon him and is irrevocably destined to overcome him. The child must understand that against this will he cannot offer any resistance. The teacher's command must be obeyed at whatever cost, even if coercive measures must be resorted to. No consideration should ever lead the teacher to desist from enforcing her command. The child *must* submit and obey. The teacher accordingly, should be careful at first to command only what she is sure to obtain. For example, she may command the child to move; since, if necessary she can *force* him to move. She may command the child to stand motionless because, if necessary, she can tie him or put him in a straight-jacket. She should never, on the other hand, command the child to "beg pardon," because the child may refuse, and in the face of this refusal the teacher may find herself helpless and lose her authority. To acquire authority in command, the teacher must possess a considerable power of suggestion; and this she can partially acquire. The teacher should be physically attractive, of an "imposing personality." She should have a clear musical voice, and some power of facial expression and gesture. These things may be in large part acquired by actual study of declamation and imitation, subjects in which the perfect teacher should be proficient. The artistic study of *command*, which the teacher may undertake, presents itself under three aspects: voice study, gesture, facial expression.

THIS PAGE IS LOCKED TO FREE MEMBERS

Purchase full membership to immediately unlock this page



HISTORY

Tens of thousands of important historical sources, many previously unobtainable, are now available for the first time with a Forgotten Books Full Membership.

Unlimited Access
\$8.99/month

Continue

*Fair usage policy applies

ling, followed by slow, insistent words —“ James, put *that book* on the table”: “ James, put that book on the *table*”: “ James, put that book *on* the table.” Thus the voice both in commanding and in describing what was commanded, while urging the child to perform the required action and guiding him to do it, was also affording us help in its suggestive power and by explanation.

Gesture. The teacher must study particularly expressive gesture. She must always accompany what she says with gestures serving both to impel the child to actions and which suggest imitation and explain the command. Gesture should be expressive enough to be readily intelligible even without words; for example, if it is desirable to bring the child to perfect quiescence, as the command is given, the teacher should stop, become almost rigid, looking sharply at the child in such a way that he may be impressed by that rigid fixity which he sees before him and be brought by suggestion to imitate it. Then to keep the child motionless, the teacher may attract his attention by a slight almost continuous hypnotizing sort of whistle. To excite an apathetic child to movement the teacher should herself move, accompanying the stress of her voice with motion in her whole body.

In the *simple command*, arm gesture only should be used and as follows:

For *Incitement*: rapid movement in straight line.

For *Explanation*: slow movement in curve.

Command of *quiescence*: gesture up and down, from without toward the body.

Command of *movement*: gesture from down, up, from within, out from the body.

Facial expression and gaze: The gaze has a powerful effect on the child. It is the same gaze which impressed the child and brought him to the first steps in his education (see our chapter on the *Education of the Gaze*). All the expressions of the eye are useful provided the teacher employs them properly. It is not a question of scowling at the child to frighten him, as might be supposed; but rather of bringing the eye as well as the whole face to express all those emotions which the teacher

must herself actually feel in the presence of an obedient or rebellious, a patient or angry child; and of giving to this expression such clearness that the child cannot possibly be mistaken as to its meaning (Séguin, page 679). The teacher's face must be expressive, mobile, hence in harmonious relationship with what is to be expressed (calmness, gaiety, effort). The expression must never vary momentarily on account of any extraneous diversion which may occur; otherwise the children will soon learn to provoke such distractions of the teacher's attention. Such commands, which demand on the teacher's part so much artistic study, will, of course, not be necessary during the whole period of the child's education.

THE END

THIS PAGE IS LOCKED TO FREE MEMBERS

Purchase full membership to immediately unlock this page

Know Your Bible

Forgotten Books'
Full Membership
provides unlimited
access to more than
28,000 volumes of
Christian literature for
\$8.99/month

**HOLY
BIBLE**

Continue

*Fair use policy applies

continued from front flap

projects of Rome, in the slums of London and (toward the end of her long life) in India. None of the fashionable recent descriptions of the American poor is so directly disturbing as Montessori's comment on what she found waiting for her at the opening of school in San Lorenzo: 'Sixty tearful, frightened children, so shy that it was impossible to get them to speak, with bewildered eyes, as though they had never seen anything in their lives.' Yet two years later these children, age six, were performing as well as the eight-year-olds in the middle-class elementary schools of Rome. It gives one to think.

"Fundamentally, however, Montessori is honored today for her original insight into the nature of the learning process and the potential of the school. . . .

"'We do not start,' she writes in these pages, 'from the conclusions of experimental psychology. . . . We start essentially from a method, and it is probable that psychology will be able to draw its conclusions from pedagogy so understood, and not vice versa.' Jerome Bruner writes better than that, but Montessori's statement is an accurate description of what he has been doing at Harvard's Center for Cognitive Studies and in his meetings with the math and science reformers. Instead of prescribing instructional procedures from learning theory, which is what American educational academicians have been trying unsuccessfully for half a century, Bruner has been working to develop a theory of instruction from what he observes in selected classrooms, hoping all the while that somewhere within this theory of instruction a valid learning theory will have left a trackable spoor. Montessori would approve."

"A remarkable book by
a remarkable human being."

— SCIENTIFIC AMERICAN



Maria Montessori was born in 1870, and she was the first woman ever granted a medical degree by an Italian university. As a child, she showed great ability in mathematics and originally intended to become an engineer. She did post-graduate work in psychiatry.

At the age of 28, Montessori became directress of a tax-supported school for defective children. Working thirteen hours a day *with the*

children, she developed material and methods which allowed them to perform reasonably well on school problems previously considered far beyond their capacity. Her great triumph, in reality and in the newspapers, came when she presented children from mental institutions at the public examinations for primary certificates, which was as far as the average Italian ever went in formal education — and her children passed the exam.

Typically, she drew from her experience the vigorous conclusion that if *these* children could be brought to the academic level reached by normal children, there had to be something horribly wrong with the education of normal children. And so she moved on to the *normal* children of the slums. Thereafter, by her own desire and by public demand, she was an educator, not a medical doctor.

Montessori's insights and methods are contained in four basic texts now republished: THE MONTESSORI METHOD, SPONTANEOUS ACTIVITY IN EDUCATION (*The Advanced Montessori Method*, volume 1), THE MONTESSORI ELEMENTARY MATERIAL (*The Advanced Montessori Method*, volume 2), and DR. MONTESSORI'S OWN HANDBOOK.

BASIC MONTESSORI BOOKS

THE MONTESSORI METHOD, by Maria Montessori. Introduction by Martin Mayer. The education of children from 3 to 6. With all the original photographs. 50 photos/figures. 448 pages. \$6.50

SPONTANEOUS ACTIVITY IN EDUCATION, by Maria Montessori. *The Advanced Montessori Method*, volume 1. The education of children from 7 to 11. 384 pages. \$6.50

THE MONTESSORI ELEMENTARY MATERIAL, by Maria Montessori. *The Advanced Montessori Method*, volume 2. The education of children from 7 to

DR. MONTESSORI'S OWN HANDBOOK by Maria Montessori. 43 photos figures plus 1 four-color photo. 17 pages. \$5.00

MONTESSORI FOR PARENTS, by Dorothy Canfield Fisher. 20 photos plus 1 four-color photo. 288 pages. \$5.95

THE MONTESSORI MANUAL FOR TEACHERS AND PARENTS, by Dorothy Canfield Fisher. Practical exercises and lessons on the use of the apparatus in homes and schools, nature study, and an extended discussion on Montessori discipline and obedience.